



**Multi-Function Machine
SERVICE MANUAL**

**MODEL: MFC6800/DCP1000
MFC9180/MFC9160**

© Copyright Brother 2001

All rights reserved.

No part of this publication may be reproduced in any form or by any means without permission in writing from the publisher.

Specifications are subject to change without notice.

PREFACE

This publication is a Service Manual covering the specifications, construction, theory of operation, and maintenance of the Brother multi-function machine. It includes information required for field troubleshooting and repair--disassembly, reassembly, and lubrication--so that service personnel will be able to understand machine function, to rapidly repair the machine and order any necessary spare parts.

To perform appropriate maintenance so that the machine is always in best condition for the customer, the service personnel must adequately understand and apply this manual.

This manual is made up of six chapters and appendices.

CHAPTER 1 GENERAL DESCRIPTION

CHAPTER 2 INSTALLATION

CHAPTER 3 THEORY OF OPERATION

CHAPTER 4 DISASSEMBLY/REASSEMBLY AND LUBRICATION

CHAPTER 5 MAINTENANCE MODE

CHAPTER 6 ERROR INDICATION AND TROUBLESHOOTING

Appendix 1. EEPROM Customizing Codes

Appendix 2. Firmware Switches (WSW)

Appendix 3. Circuit Diagrams

This manual describes the models and their versions to be destined for major countries. The specifications and functions are subject to change depending upon each destination.

SAFETY INFORMATION

Laser Safety (110-120V Model only)

This printer is certified as a Class 1 laser product under the US Department of Health and Human Services (DHHS) Radiation Performance Standard according to the Radiation Control for Health and Safety Act of 1968. This means that the printer does not produce hazardous laser radiation.

Since radiation emitted inside the printer is completely confined within the protective housings and external covers, the laser beam cannot escape from the machine during any phase of user operation.

CDRH Regulations (110-120V Model only)

The Center for Device and Radiological Health (CDRH) of the US Food and Drug Administration implemented regulations for laser products on August 2, 1976. These regulations apply to laser products manufactured from August 1, 1976. Compliance is mandatory for products marketed in the United States. The label shown below indicates compliance with the CDRH regulations and must be attached to laser products marketed in the United States.

The label for Chinese products

MANUFACTURED: JUNE 2001 C
BROTHER CORP. (ASIA) LTD.
BROTHER BUJI NAN LING FACTORY
Gold Garden Industry, Nan Ling Village, Buji,
Rong Gang, Shenzhen, China.
This product complies with FDA radiation
performance standards, 21 CFR Subchapter J.

CHAPTER 1

GENERAL DESCRIPTION

CHAPTER 1 GENERAL DESCRIPTION

CONTENTS

1.1	OUTLINE.....	1-1
1.1.1	External Appearance and Weight	1-1
1.1.2	Components	1-1
1.2	SPECIFICATIONS.....	1-2

1.1 OUTLINE

1.1.1 External Appearance and Weight

The figure below shows the machine appearance and approximate dimensions.

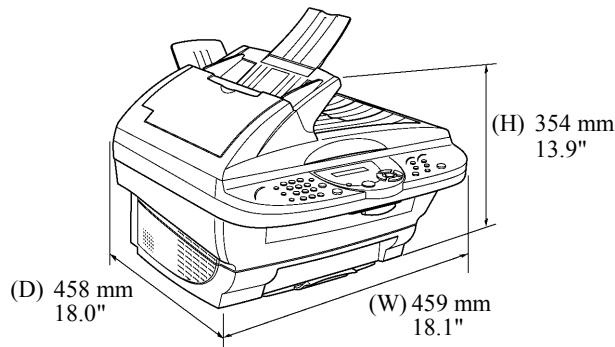

Weight:	Machine proper	Approx. 11 kg
	Machine (incl. drum unit & toner cartridge)	Approx. 12 kg
	In package	Approx. 16 kg

1.1.2 Components

The machine consists of the following major components:

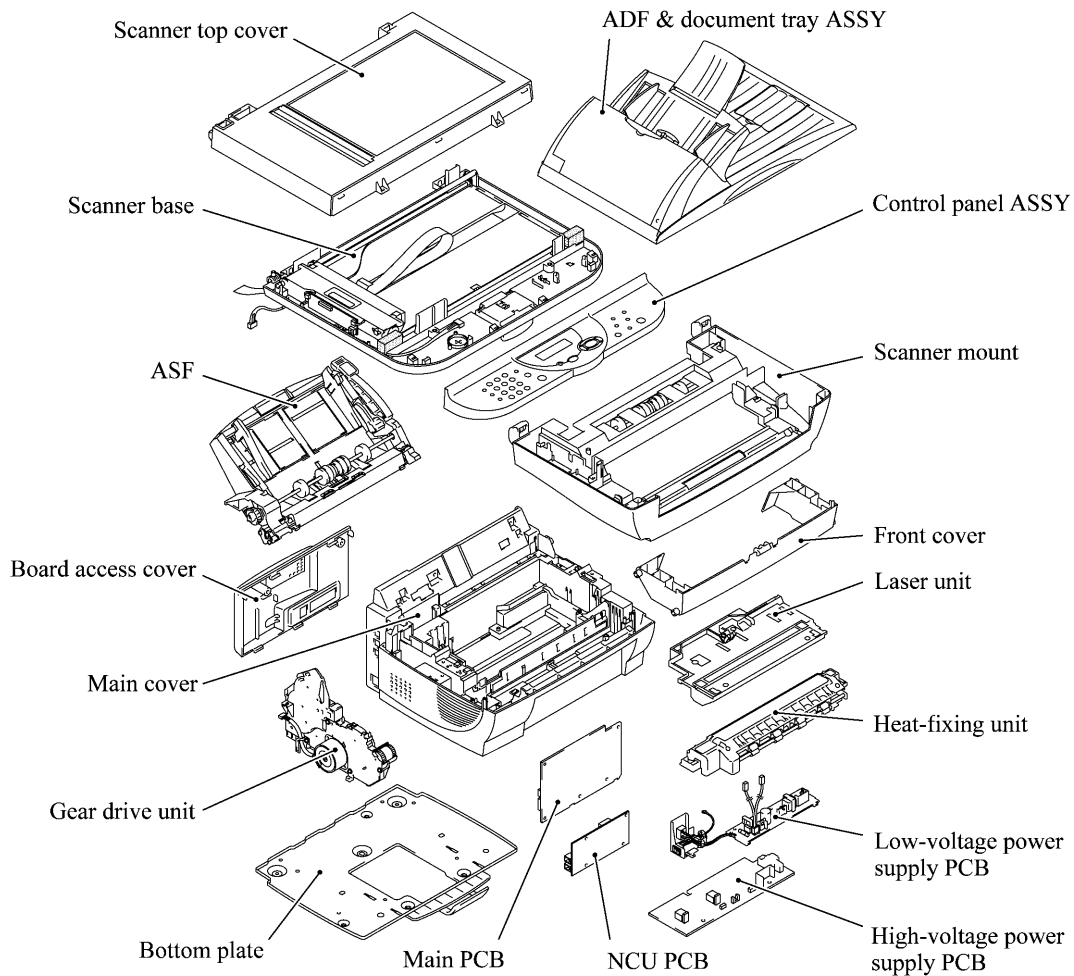

1.2 SPECIFICATIONS

(1/2)

	YL4-FB(MFC)	YL4-DCP
Model Name	MFC 6800	DCP 1000
GENERAL		
Print Engine	Laser (YL4)	Laser (YL4)
Modem Speed (bps)	14,400 (Fax)	-
Transmission Speed (sec.)	6 (Brother#1,MMR)	-
ITU-T Group	G3	-
Coding Method	MH/MR/MMR	-
Input/Output Width	5.8"-8.5"/3.5"-8.5"	5.8"-8.5"/3.5"-8.5"
Input/Output Length	5"-14"/5"-14"	5"-14"/5"-14"
ADF (pages)	Up to 30	Up to 30
LCD Size	16 characters x 2 lines	16 characters x 2 lines
LCD Backlight	No	No
Backup Clock	Yes (1 hour)	Yes (1 hour)
Memory Capacity (physical)	8 Mbytes (RAM)	8 Mbytes (RAM)
Optional Memory	No	No
Dimensions w/ Carton (WxDxH)	596 x 566 x 452 mm	596 x 566 x 452 mm
Dimensions w/o Carton (WxDxH)	459 x 458 x 354 mm	459 x 458 x 354 mm
Weight w/ Carton	16 kg	16 kg
Weight w/o Carton	11 kg	11 kg
Color	Gray 1495	Gray 1495
Operating Environment Temperature	10 - 32.5 degrees Centigrade	10 - 32.5 degrees Centigrade
Humidity	20 - 80%	20 - 80%
Power Source	120 VAC 50/60Hz	120 VAC 50/60Hz
Power Consumption (Sleep/Standby/Peak)	15W/ 75W/ 940W or less	15W/ 75W/ 940W or less
On/Off Switch	Yes	Yes
Warm Up Time	Approx. 13 sec.	Approx. 13 sec.
TELEPHONE		
Handset	No	-
One-Touch Dial	No	-
Speed Dial	100	-
Speaker Phone	No	-
Chain Dialing	Yes	-
Caller ID	Yes	-
Call Waiting Caller ID	No	-
Distinctive Ringing	Yes	-
Call Manage	No	-
Hold/Mute Key	No	-
Power Failure Dialing	No	-
Speaker (Volume)	Yes (3 steps + OFF)	-
Ring (Volume)	Yes (3 steps + OFF)	-
Handset Volume	-	-
PBX Feature	No	-
Transfer Method	No	-
FAX		
Internet FAX	N/A	-
Easy Receive/Fax Detect	Yes	-
Fax/Tel Switch	-	-
Enhanced Remote Activate	Yes	-
Scan Speed (sec./page, A4:Standard)	Approx. 3	-
Memory Transmission (Brother#1 Chart)	500 pages (MMR/Standard Resolution)	-
Memory Transmission (ITU-T Chart)	400 pages (MMR/Standard Resolution)	-
Broadcasting	Yes (150 locations)	-
Manual Broadcasting	Yes	-
Out-of-Paper Reception (Brother #1 Chart)	500 pages (MMR/Standard Resolution)	-
Out-of-Paper Reception (ITU-T Chart)	400 pages (MMR/Standard Resolution)	-
Auto Reduction	Yes	-
ECM (Error Correction Mode)	Yes	-
Group Dial	Yes (up to 6)	-
Memory Security	No	-
Memory Backup	No	No
Color FAX (Document Send/Receive)	No	-
Color FAX (Memory Send/Receive)	No	-
LIST/REPORT		
Activity Report/Journal Report	Yes (up to 200)	-
Transmission Verification Report	Yes	-
INTERFACE		
External TAD Interface	Yes	No
Host Interface (Serial)	No	No
Host Interface (IEEE1284)	Yes	Yes
Host Interface (USB)	Yes	Yes
LAN Interface	No	No
Acceptable Media Card Slot	N/A	N/A
Analog Video Port	N/A	N/A

	YL4-FB(MFC)	YL4-DCP
Model Name	MFC 6800	DCP 1000
PRINTER		
Color/Mono	Mono	Mono
Engine Type	Laser (YL4)	Laser (YL4)
Resolution (dpi)	600 x 600	600 x 600
Speed (ppm)	up to 10	up to 10
Paper Capacity (sheets)	200	200
Additional Paper Capacity (sheets)	No	No
Output Paper Capacity (sheets)	50	50
Standard Print Language	Windows GDI	Windows GDI
Emulation	No	No
Resident Fonts	No	No
Fonts Disk Based	Yes	Yes
Paper Handling Size	LTR, LGL, A4, B5, A5, EXE	LTR, LGL, A4, B5, A5, EXE
Manual Feed Slot	N/A	N/A
Other Paper Type	OHP, Envelopes, Organizer	OHP, Envelopes, Organizer
Sheet Weight (Paper Tray)	64-158 g/m ² (16 - 42 lb)	64-158 g/m ² (16 - 42 lb)
(Manual Slot)	N/A	N/A
Printer Driver	Win95/98/98SE/Me/2000Professional/ NT4.0WS MacOS 8.5.1-9.1	Win95/98/98SE/Me/2000Professional/ NT4.0WS MacOS 8.5.1-9.1
COPY		
Color/Mono	Mono	Mono
Speed (cpm)	Up to 10	Up to 10
Multi Copy (Stack)	Yes	Yes
Multi Copy (Sort)	Yes (ADF only)	Yes (ADF only)
Reduction/Enlargement (%)	25 -- 400 in 1% increments	25 -- 400 in 1% increments
Resolution (dpi)	300 x 300	300 x 300
First Copy Out Time (From Ready Mode/ADF)	Approx. 13 sec.	Approx. 13 sec.
(From Ready Mode/FB)	Approx. 12 sec.	Approx. 12 sec.
SCANNER		
Color/Mono	Color	Color
Resolution(Optical : dpi)	600x300 (Max. 600x2,400)	600x300 (Max. 600x2,400)
Resolution(Int. : dpi)	9,600x9,600	9,600x9,600
Gray Scale	256	256
Color Depth	24 bit (8 bits x 3)	24 bit (8 bits x 3)
TWAIN Compliant&Operating System	Win95/98/98SE/Me, WinNT4.0WS/ 2000Professional, MacOS 8.6-9.1	Win95/98/98SE/Me, WinNT4.0WS/ 2000Professional, MacOS 8.6-9.1
PCI Scanner (Parallel/Serial)	Parallel/USB	Parallel/USB
BUNDLED SOFTWARE		
For Windows		
Support OS version	Win95/98/98SE/Me, WinNT4.0WS/2000Professional	Win95/98/98SE/Me, WinNT4.0WS/2000Professional
Printer Driver	Yes	Yes
TWAIN	Yes	Yes
Viewer	Yes	Yes
Pop Up Menu	Yes	Yes
OCR	Yes	Yes
PC Fax	Yes(TX:FAX Share only)	N/A
Remote Setup	Yes	No
PC Diagnostics	Yes	No
Others	Auto E-mail Printing(Win 95/98(SE)/Me only)	Auto E-mail Printing(Win 95/98(SE)/Me only)
For iMac/G3/G4		
Support OS version	Printer Driver MacOS 8.5.1-9.1 MacOS 8.6-9.1	MacOS 8.5.1-9.1 MacOS 8.6-9.1
Printer Driver	Yes	Yes
TWAIN	Yes	Yes
Viewer	Yes	Yes
Pop Up Menu	No	No
OCR	Yes	Yes
PC Fax	Yes	No
Remote Setup	No	No
PC Diagnostics	No	No
Others	-	-
ACCESSORY		
Life / Yield	Starter: 2,200 pages @5% coverage	Stater: 2,200 pages @5% coverage
Toner : TN-250	Regular:2,200 pages @5% coverage	Regular:2,200 pages @5% coverage
Drum : DR-250	20,000 pages @5% cvrg: 20 pages/job 8,000 pages @5% cvrg: 1 page/job	20,000 pages @5% cvrg: 20 pages/job 8,000 pages @5% cvrg: 1 page/job

	YL4-FB(w/ Modem)	YL4-FB(w/o Modem)
Model Name	MFC-9180	MFC-9160
GENERAL		
Print Engine	Laser (YL4)	Laser (YL4)
Modem Speed(bps)	14,400 (Fax)	-
Transmission Speed(sec.)	Approx. 6 (brother #1chart,MMR)	-
ITU-T Group	G3	-
Coding Method	MH/MR/MMR	-
Input/Output Width	5.8"-8.5"/3.5"-8.5"	5.8"-8.5"/3.5"-8.5"
Input/Output Length	5"-14"/5"-14"	5"-14"/5"-14"
ADF(pages)	Up to 30 (75 g/m ²)	Up to 30 (75 g/m ²)
LCD size	16 characters x 2 lines	16 characters x 2 lines
LCD Backlight	Yes	Yes
Backup Clock	Yes (9 hours)	Yes (1 hour)
Memory Capacity (physical)	8 Mbytes (RAM)	8 Mbytes (RAM)
Optional Memory	N/A	N/A
Dimensions w/ Carton (WxDxH)	596 x 566 x 452 mm	596 x 566 x 452 mm
Dimensions w/o Carton (WxDxH)	459 x 458 x 354 mm	459 x 458 x 354 mm
Weight w/ Carton	16 kg	16 kg
Weight w/o Carton	11 kg	11 kg
Color	Gray 1495	Gray 1495
Operating Environment Temperature	10 - 32.5 degrees Centigrade	10 - 32.5 degrees Centigrade
Humidity	20 - 80 %	20 - 80 %
Power Source	220-240 VAC 50/60Hz	220-240 VAC 50/60Hz
Power Consumption (Sleep/Standby/Peak)	15W/ 75W/ 940W or less	15W/ 75W/ 940W or less
On/Off Switch	Yes	Yes
Warm Up Time	Approx. 12 sec.	Approx. 12 sec.
TELEPHONE		
		N/A
Handset	No	-
One-Touch Dial	No	-
Speed Dial	100	-
Speaker Phone	No	-
Chain Dialing	Yes	-
Caller ID	N/A	-
Call Waiting Caller ID	N/A	-
Distinctive Ringing	Yes (UK, DEN only)	-
Call Manage	No	-
Hold/Mute key	N/A	-
Power Failure Dialing	N/A	-
Speaker Volume	Yes (3 steps + OFF)	-
Ring Volume	Yes (3 steps + OFF)	-
Handset Volume	N/A	-
PBX Feature	Yes	-
Transfer Method	Flash	-
FAX		
		N/A
Internet FAX	N/A	-
Easy Receive/Fax Detect	Yes	-
Fax/Tel Switch	Yes	-
Enhanced Remote Activate	Yes	-
Quick Scan(Memory transmission)	Yes as default. Approx.2.8 sec/page (A4 standard)	-
Memory Transmission (ITU-T #1 Chart)	400 pages (MMR/Standard Resolution)	-
Memory Transmission (Brother#1 Chart)	500 pages (MMR/Standard Resolution)	-
Broadcasting	Yes (150 locations)	-
Manual Broadcasting	Yes (50 locations)	-
Out-of-Paper Reception (ITU-T #1 Chart)	400 pages (MMR/Standard Resolution)	-
Out-of-Paper Reception (Brother#1 Chart)	500 pages (MMR/Standard Resolution)	-
Auto Reduction	Yes	-
ECM(Error Correction Mode)	Yes	-
Group Dial	Yes (up to 6)	-
Memory Security	Yes	-
Memory Backup	Yes (Max. 4 days)	-
Color FAX (Document Send/Receive)	No / No	-
Color FAX (Memory Send/Receive)	No / No	-
LIST/REPORT		
Activity Report/Journal Report	Yes (up to 200)	-
Transmission Verification Report	Yes	-
INTERFACE		
External TAD Interface	Yes	No
Host Interface (Serial)	No	No
Host Interface (IEEE1284)	Yes	Yes
Host Interface (USB)	Yes	Yes
LAN Interface	No	No
Acceptable Media Card Slot	N/A	N/A
Analog Video Port	N/A	N/A

	YL4-FB(w/ Modem)	YL4-FB(w/o Modem)
Model Name	MFC-9180	MFC-9160
PRINTER		
Color/Mono	Mono	Mono
Engine Type	Laser (YL4)	Laser (YL4)
Resolution (dpi)	600 x 600	600 x 600
Speed (ppm)	up to 10	up to 10
Paper Capacity (sheets)	200 (75 g/m ²)	200 (75 g/m ²)
Additional Paper Capacity (sheets)	No	No
Output Paper Capacity (sheets)	50	50
Standard Print Language	Windows GDI	Windows GDI
Emulation	Yes (PCL5e)	Yes (PCL5e)
Resident Fonts	Yes (Bitmap font: LetterGothic16.66, OCR-A, OCR-B, Scalable font: 49 fonts)	Yes (Bitmap font: LetterGothic16.66, OCR-A, OCR-B, Scalable font: 49 fonts)
Fonts Disk Based	Yes	Yes
Paper Handling Size	LTR, LGL, A4, A5, EXE, A6, ISO B5, ISO B6	LTR, LGL, A4, A5, EXE, A6, ISO B5, ISO B6
Manual Feed Slot	N/A	N/A
Other Paper Type	OHP, Envelopes, Organizer	OHP, Envelopes, Organizer
Sheet Weight (Paper Tray)	64-158 g/m ² (16 - 42 lb)	64-158 g/m ² (16 - 42 lb)
(Manual Slot)	N/A	N/A
Printer Driver	Win95/98(SE)/Me/NT4.0WS/2000 professional	Win95/98(SE)/Me/NT4.0WS/2000 professional
COPY		
Color/Mono	Mono	Mono
Speed (cpm)	Up to 10	Up to 10
Multi Copy (Stack)	Yes	Yes
Multi Copy (Sort)	Yes (on ADF only)	Yes (on ADF only)
Reduction/Enlargement (%)	25 to 400 in 1% increments	25 to 400 in 1% increments
Resolution (dpi)	300 x 300 (print)	300 x 300 (print)
First Copy Out Time (From Ready Mode/ADF)	Approx. 13 sec.	Approx. 13 sec.
(From Ready Mode/FB)	Approx. 12 sec.	Approx. 12 sec.
SCANNER		
Color/Mono	Color/Mono	Color/Mono
Resolution (Optical: dpi)	600 x 2,400	600 x 2,400
Resolution (Int.: dpi)	9,600 x 9,600	9,600 x 9,600
Gray Scale	256	256
Color Depth	24 bits (8 bits x 3)	24 bits (8 bits x 3)
TWAIN Compliant&Operating System	Win95/98(SE)/Me/NT4.0WS/2000Professional MacOS 8.6-9.1	Win95/98(SE)/Me/NT4.0WS/2000Professional MacOS 8.6-9.1
PCI Scanner (Parallel/Serial)	Parallel/USB	Parallel/USB
BUNDLED SOFTWARE(For Windows)		
For Windows		
Support OS version	Win95/98/98SE/Me, WinNT4.0WS/2000Profrrsional	Win95/98/98SE/Me, WinNT4.0WS/2000Profrrsional
Printer Driver	Yes	Yes
TWAIN	Yes	Yes
Viewer	Yes	Yes
Pop Up Menu	Yes	Yes
OCR	Yes	Yes
PC Fax	Yes	No
Remote Setup	Yes	No
PC Diagnostics	Yes	Yes
Others	No	No
For iMac/G3/G4		
Support OS version	Print Others MacOS8.5.1-9.1 MacOS8.6-9.1	MacOS8.5.1-9.1 MacOS8.6-9.1
Printer Driver	Yes	Yes
TWAIN	Yes	Yes
Viewer	No	No
Pop Up Menu	No	No
OCR	No	No
PC Fax	Yes	No
Remote Setup	No	No
PC Diagnostics	No	No
Others	No	No
ACCESSORY		
Life / Yield	Starter: N/A	Starter: N/A
Toner:TN-8000	Regular:2,200 pages @5% coverage	Regular:2,200 pages @5% coverage
Drum:DR-8000	20,000 pages @5% cvrg: Continuous printing 8,000 pages @5% cvrg: 1 page/job	20,000 pages @5% cvrg: Continuous printing 8,000 pages @5% cvrg: 1 page/job

CHAPTER 2

INSTALLATION

CHAPTER 2 INSTALLATION

CONTENTS

2.1	INSTALLING THE UPDATE DATA TO THE FACSIMILE MACHINE.....	2-1
2.2	SETTING ID CODES TO FACSIMILE MACHINES.....	2-3

2.1 INSTALLING THE UPDATE DATA TO THE FACSIMILE MACHINE

If the program version is updated or the main PCB is replaced, then install the update program onto the flash ROM of the main PCB.

The program installation requires a PC/AT-compatible computer (which is capable of running MS-DOS or its compatible OS).

Connecting the facsimile machine to your computer

- (1) Make sure that your computer is turned off.
- (2) Make sure that the machine's power cord is unplugged from a wall socket. (If the machine has a power ON/OFF switch, make sure that the switch is turned off.)
- (3) Connect the parallel interface cable to the parallel port on the back of the machine and secure it with the lock wires.
- (4) Connect the other end of the interface cable to the printer port of your computer and secure it with the two screws.
- (5) While pressing the **5** key on the machine's control panel, plug the machine's power cord into a wall socket (or turn on the power ON/OFF switch if the machine has the switch).
- (6) Check to see that the following pattern displays on the LCD. If it does not display, go back to step (2) above.

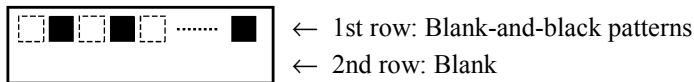

- (7) Turn on your computer.

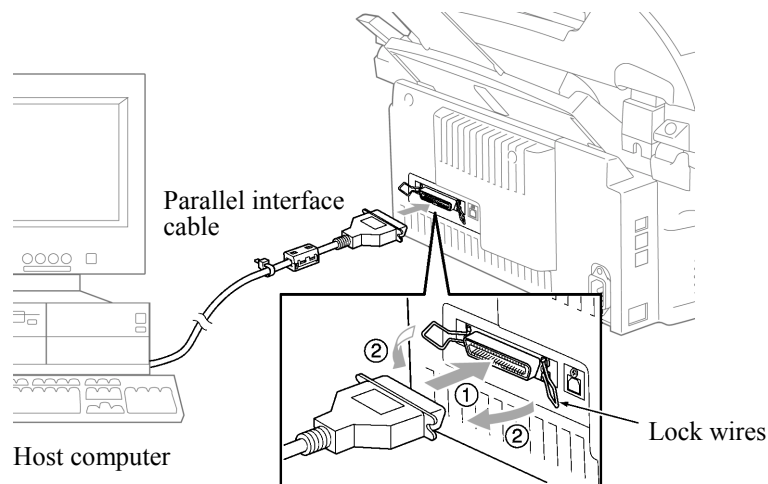

Installing the update data onto the flash ROM of the facsimile machine

NOTE: The following is an installation procedure example on a PC that is running Windows 95/98.

- (1) Copy the update data and transfer utility onto the desired directory of the hard disk.
e.g., C:\UPDATE
- (2) Click the Start button, point to Programs, and then click MS-DOS Prompt to open an MS-DOS window.
- (3) Type the drive letter where the update data and transfer utility are located. In the above example, type C:\ from the command line and press the **ENTER** key.

Then type CD UPDATE and press the **ENTER** key.

- (4) Check that your computer is connected with the facsimile machine correctly.
- (5) To start the transfer utility transmitting the update data to the flash ROM of the facsimile machine, type the following:

```
ICEN filename /b
```

Then press the **ENTER** key.

During downloading, the machine beeps *intermittently*.

Upon completion of the downloading, the machine beeps *continuously*.

NOTE: If the facsimile machine cannot return to the standby state after completion of downloading, turn the power off and on.

2.2 SETTING ID CODES TO FACSIMILE MACHINES

■ Function

Brother facsimile machines are assigned unique ID codes (character strings) at the factory. If you replace the main PCB of the machine, the machine will lose its assigned ID code so that it will not be identified by the connected PC*.

You need to assign a unique ID code (character string) to the machine according to the procedure given here. For models covered by this manual, set serial numbers given to individual machines as ID codes.

(*ID codes are essential when more than one machine is connected to a single PC via USB.)

■ Connecting each of facsimile machines to your PC

- (1) Make sure that your PC is turned off.
- (2) Make sure that the machine's power cord is unplugged from a wall socket or other power source.
- (3) Connect the interface cable to the parallel interface port on the back of the facsimile machine and secure it with the lock wires.
- (4) Connect the other end of the interface cable to the printer port of your PC and secure it with the two screws.
- (5) Plug the machine's power cord into a wall socket or other power source.
- (6) Turn on your PC.

■ Operating Procedure

- (1) On your PC, run the ID setting utility. Follow the instructions shown on the PC's screen and enter the 9-digit serial number (e.g., G01012345) printed on the nameplate labeled to the back of the facsimile machine as an ID code. Then press the Enter key.

The ID setting utility will transmit the ID code data from your PC to the facsimile machine and then it will terminate.

The facsimile machine will automatically return to the standby mode.

- (2) To check whether the entered character string (ID code) is correct, make the machine enter the maintenance mode (refer to CHAPTER 5, Section 5.1) and then press the **1** key twice (Subsection 5.3.5).

The facsimile machine will print out a Configuration List. At the right top of the list, "SER.#: BROXXXXXXXXXX" is printed.

- (3) Check that the character string entered in step (2) is printed in "XXXXXXXXXX."

If it is OK, press the **9** key twice to exit from the maintenance mode.

If something other than that is printed in XXXXXXXXXXXX, check the connection between the PC and facsimile machine and go back to step (1).

CHAPTER 3

THEORY OF OPERATION

CHAPTER 3 THEORY OF OPERATION

CONTENTS

3.1	OVERVIEW	3-1
3.2	MECHANISMS	3-2
3.2.1	Scanner Mechanism	3-4
3.2.2	Laser Printing Mechanism.....	3-6
3.2.2.1	Paper pulling-in, registration, feeding, and ejecting mechanism.....	3-6
3.2.2.2	Print process mechanism.....	3-8
3.2.2.3	Heat-fixing mechanism	3-9
3.2.3	Sensors and Actuators	3-10
3.3	CONTROL ELECTRONICS	3-12
3.3.1	Configuration	3-12

3.1 OVERVIEW

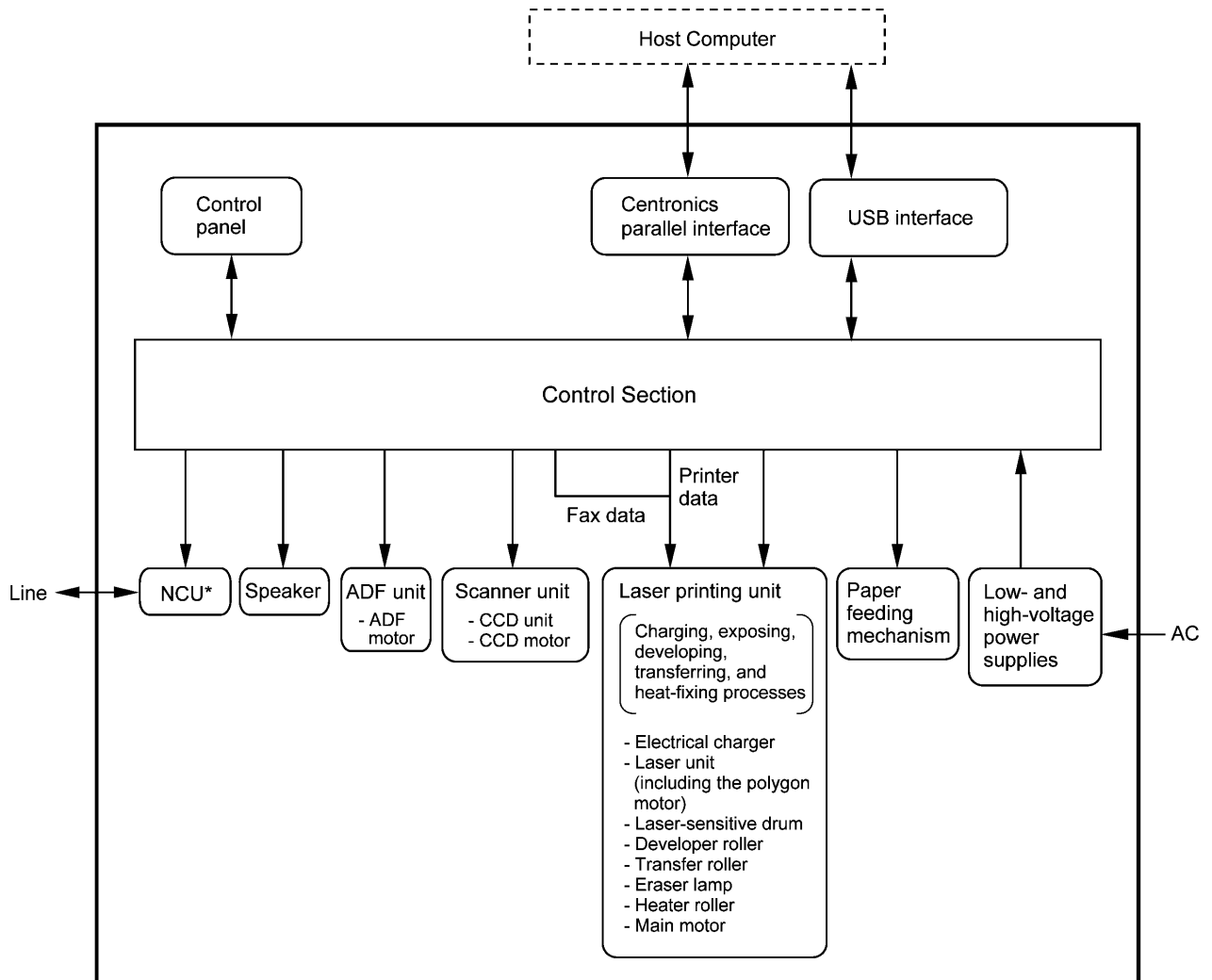

* Provided on models supporting facsimile function.

3.2 MECHANISMS

The facsimile machine is classified into the following mechanisms:

- SCANNER MECHANISM
 - ADF mechanism
 - Document scanning mechanism
- LASER PRINTING MECHANISM
 - Paper pulling-in and registration mechanism
 - Print process mechanism (consisting of charging, exposing, developing, transferring, and erasing processes) with paper feeding mechanism
 - Heat-fixing mechanism with paper feeding mechanism
 - Paper ejecting mechanism
- SENSORS AND ACTUATORS

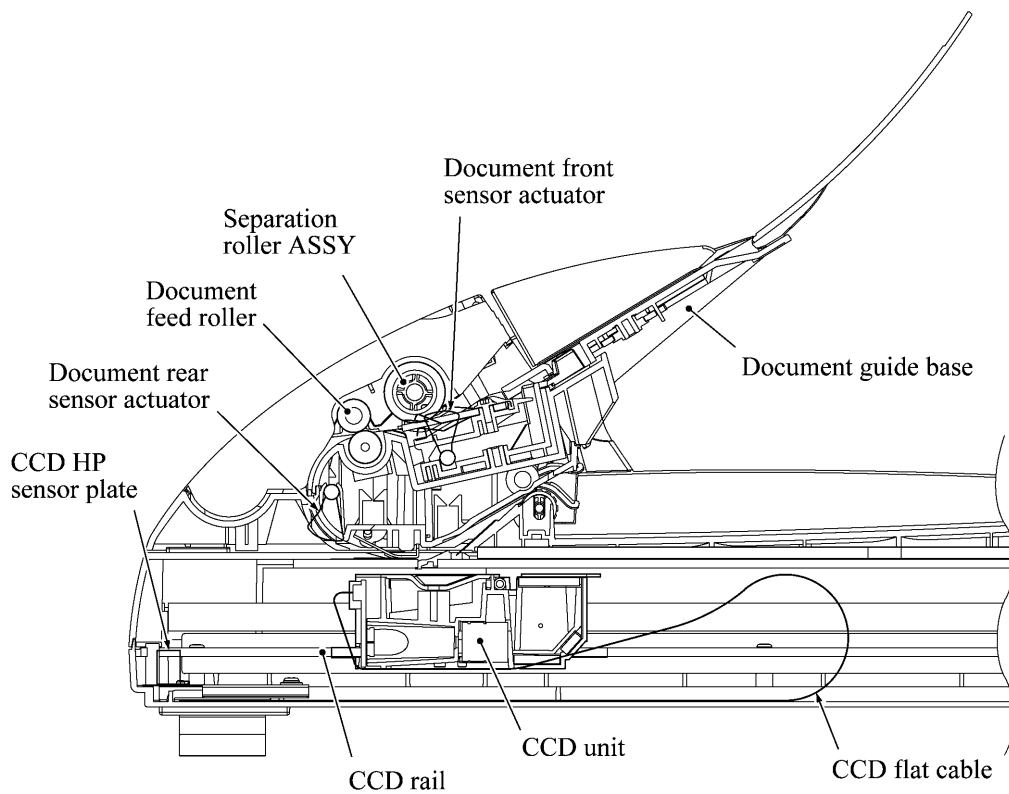

SCANNER MECHANISM (Viewed from the front)

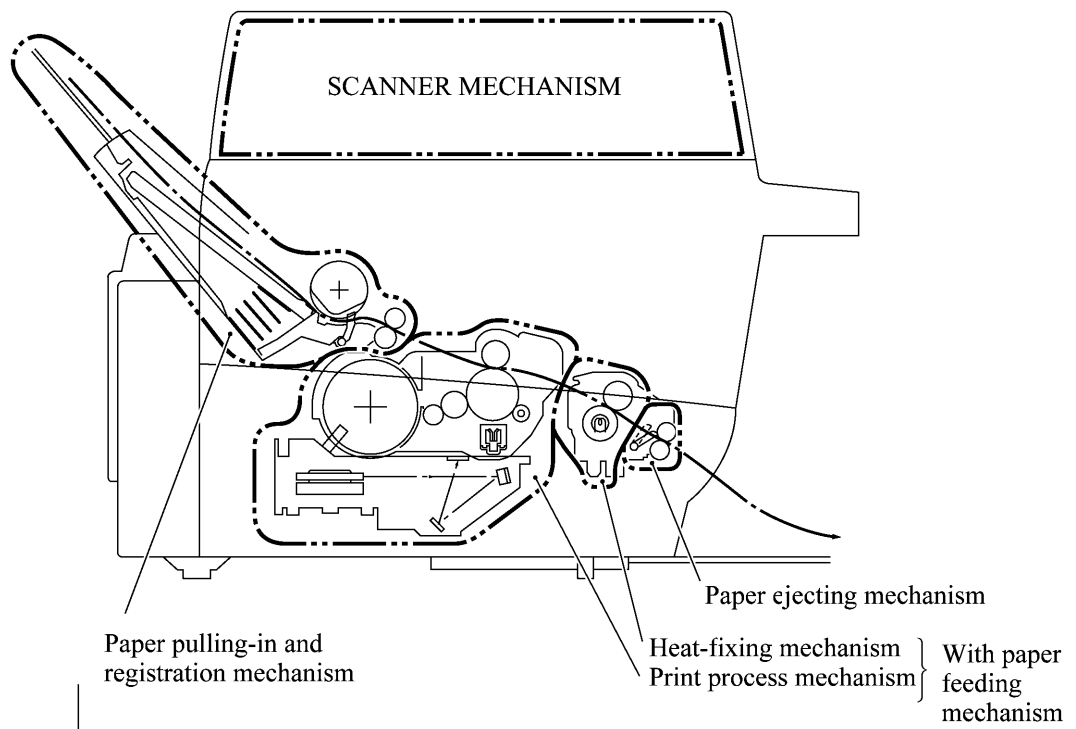

LASER PRINTING MECHANISM (Viewed from the left)

3.2.1 Scanner Mechanism

This mechanism consists of the document guide base, ADF & document tray ASSY and scanner unit.

The ADF (automatic document feeder) unit contains a separation roller ASSY, document feed roller ASSY, document ejection roller, ADF motor, and document front and rear sensors.

The scanner unit consists of a scanner top cover, CCD unit, CCD drive mechanism, CCD HP sensor, and scanner base.

For details about the sensors, refer to Subsection 3.2.3.

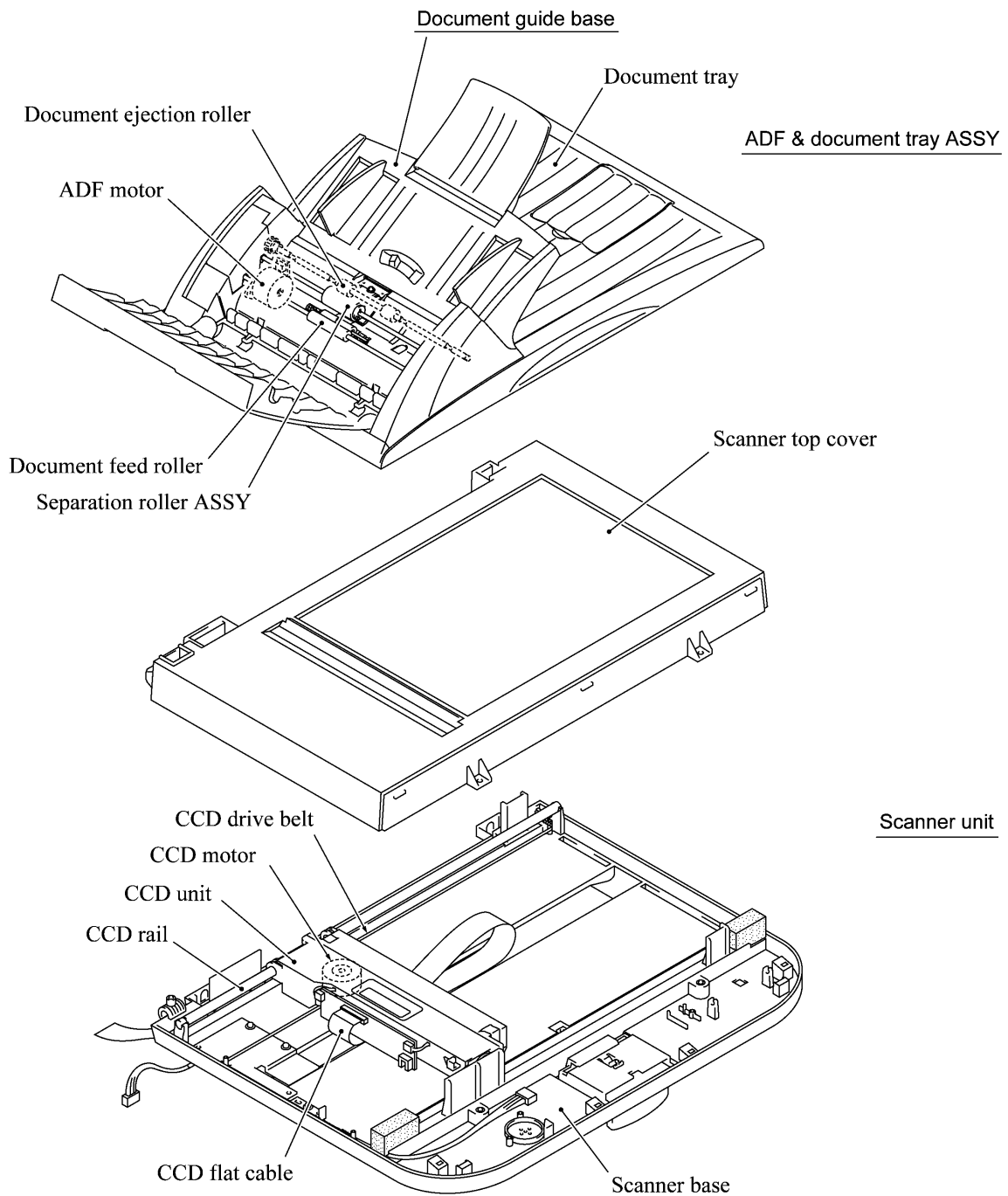

This scanner mechanism supports a dual scanning system.

- (1) If you set documents on the document guide base with their faces up and start the scanning operation, then the ADF motor rotates to pull in those documents into the ADF unit, starting from the top sheet to the bottom, page by page. Each document curves downwards and turns to the right with the document feed roller so as to advance above the CCD unit, and then it is fed out to the document tray with the document ejection roller ASSY.

This way, documents move above the CCD unit being kept in a stationary position.

- (2) If you open the ADF & document tray ASSY, put a sheet of document (or put a bound book opened) on the glass of the scanner top cover, close the ADF & document tray ASSY, and start the scanning operation, then the CCD drive mechanism will be driven.

The CCD motor built in the CCD unit rotates. As illustrated below, the CCD drive gear and idle pulley carry the CCD drive belt on the underside of the CCD unit, so clockwise and counterclockwise rotations of the CCD motor move the CCD unit to the right and left, respectively.

In this scanning system, the CCD unit moves horizontally beneath a document being kept in stationary position.

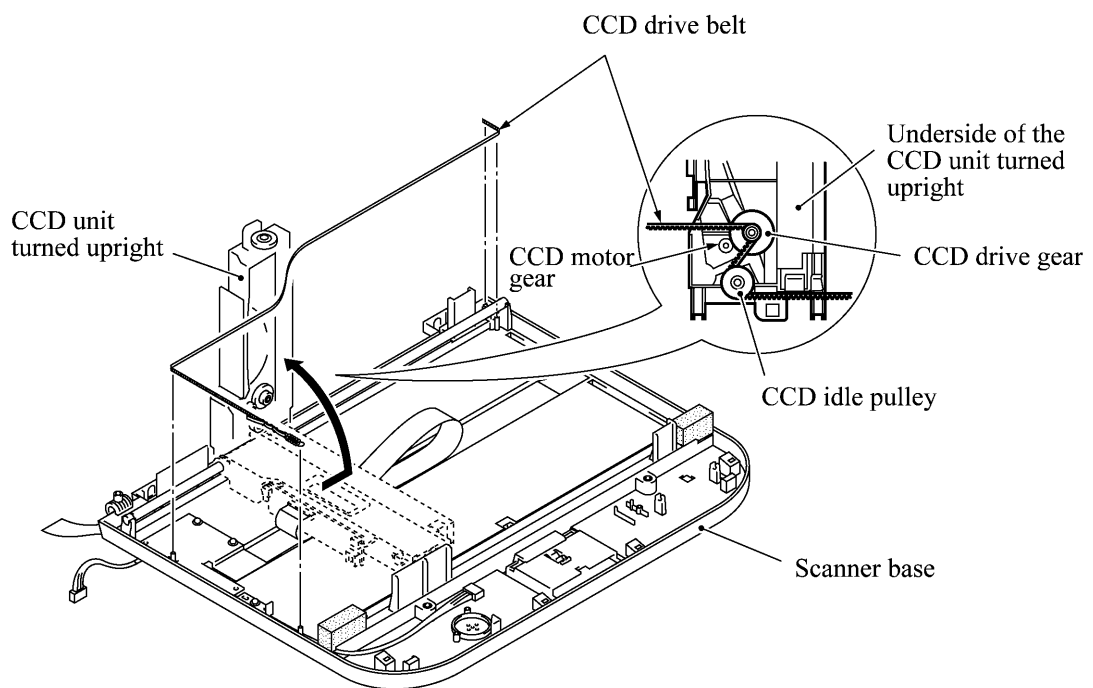

The CCD unit contains a charge coupled device (CCD) image sensor. The cold-cathode fluorescent lamp illuminates a document and the reflected light of the scanned image data is transmitted via the mirrors into the lens which reduces the scanned data so as to form the image on the CCD.

3.2.2 Laser Printing Mechanism

3.2.2.1 Paper pulling-in, registration, feeding, and ejecting mechanism

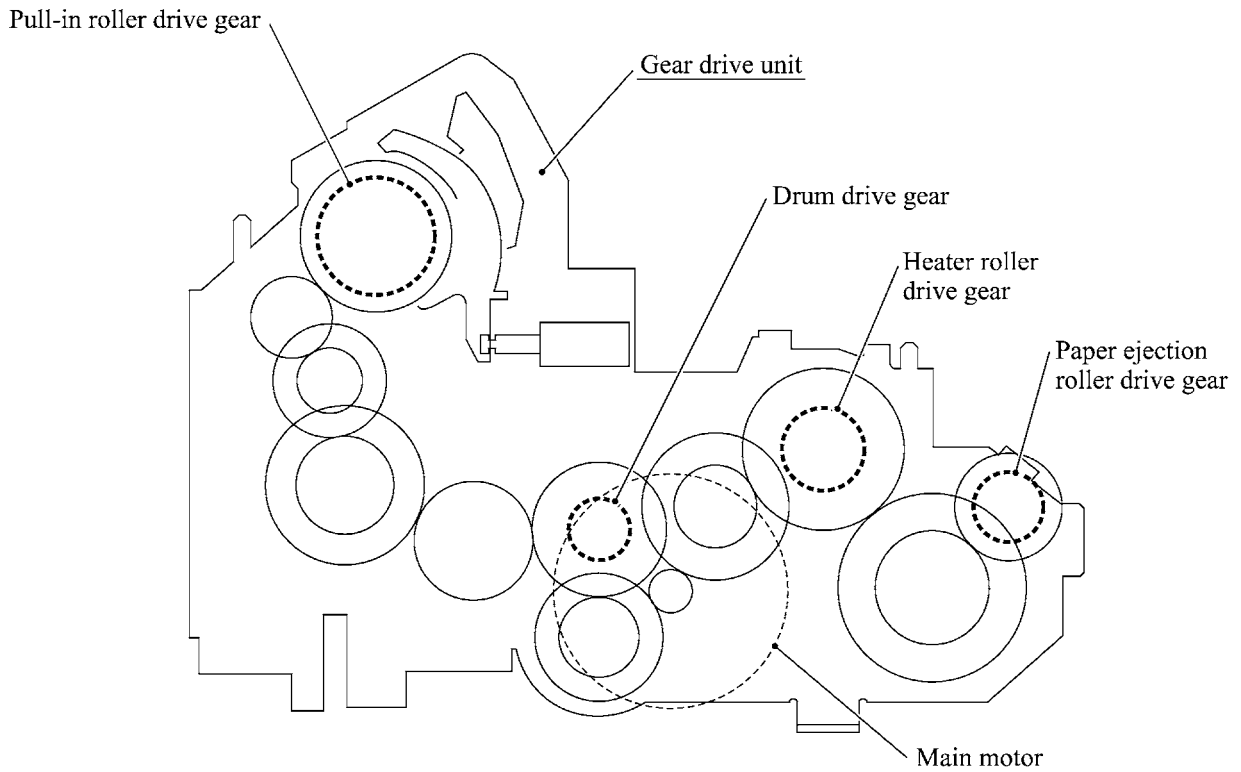
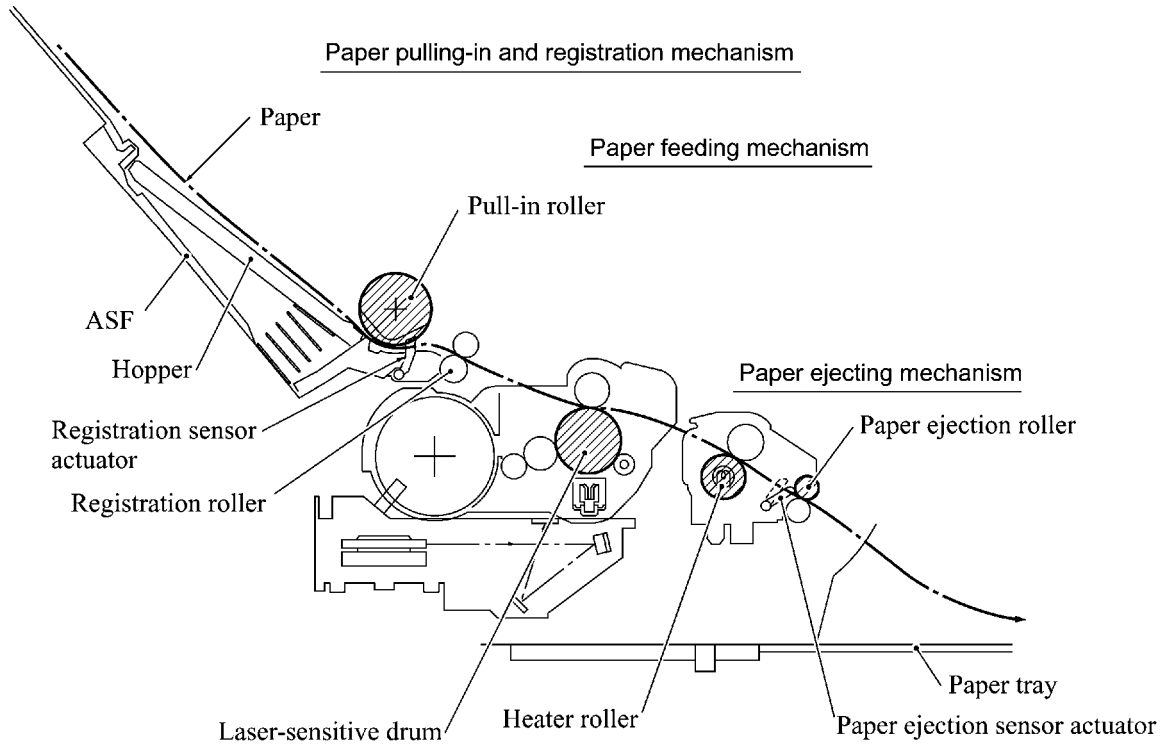

Paper pulling-in and registration mechanism

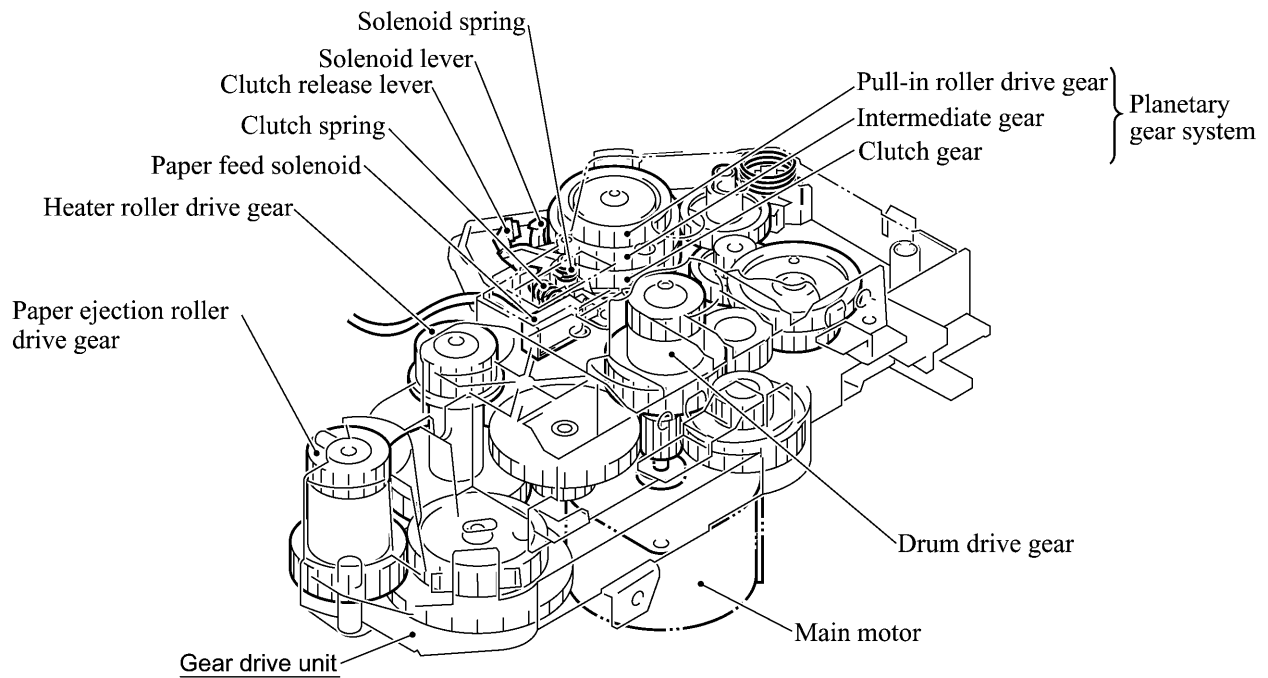

The paper pulling-in and registration mechanism consists of the pull-in roller gear (incorporated in the auto sheet feeder ASF), planetary gear system, paper feed solenoid, solenoid lever, clutch release lever, and registration sensor. (For the details about the sensor, refer to Subsection 3.2.3.)

If the main motor rotates clockwise, the rotation is transmitted to the intermediate gear of the planetary gear system. As the intermediate gear rotates, the pull-in roller drive gear also rotates since the clutch gear is locked by the solenoid lever and the clutch release lever. Accordingly, the pull-in roller in the ASF rotates to pull in paper into the machine, a sheet at a time.

If the paper feed solenoid is retracted and the clutch release lever is operated according to the cam profile of the pull-in roller drive gear so as to release the clutch gear, the clutch gear rotates and the pull-in roller drive gear does not rotate. This way, the clutch gear switches the transmission of the motor rotation to the pull-in roller drive gear on and off.

The solenoid on/off timing and the clutch release lever timing allow this mechanism to pull in a sheet and register it against the registration roller.

Paper feeding and ejecting mechanism

If the main motor rotates clockwise, the rotation is transmitted via the gear train to the drum drive gear, heater roller drive gear, and paper ejection roller drive gear.

After the paper passes through the heat-fixing process, it will be ejected onto the paper tray.

If the leading edge of the paper pushes up the actuator of the paper ejection sensor, the photosensor becomes opened, signaling the start of paper ejection. If the trailing edge has passed through the sensor actuator, the sensor becomes closed, signaling the completion of paper ejection. Then, the main motor stops rotation.

3.2.2.2 Print process mechanism

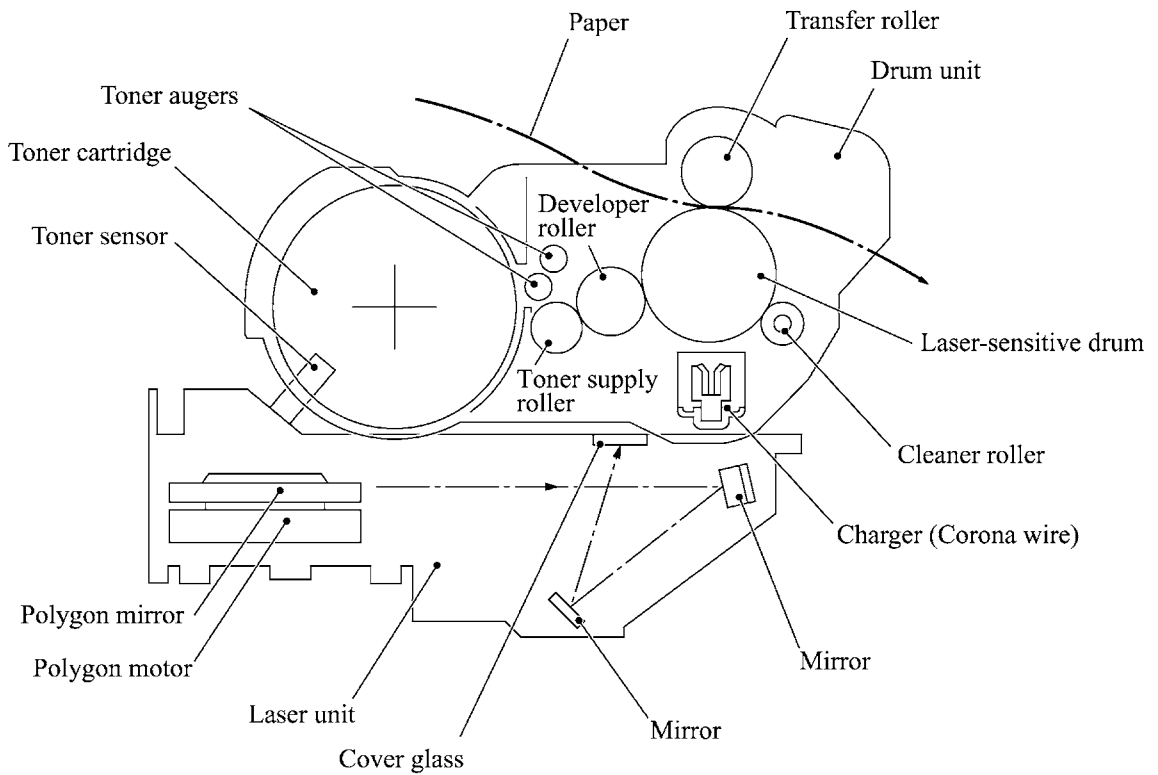

The print process unit works with laser beam, electrical charges, and toner. The graph below shows the transition of electrical charge on the surface of the laser-sensitive drum through the five processes: charging, exposing, developing, transferring, and erasing processes.

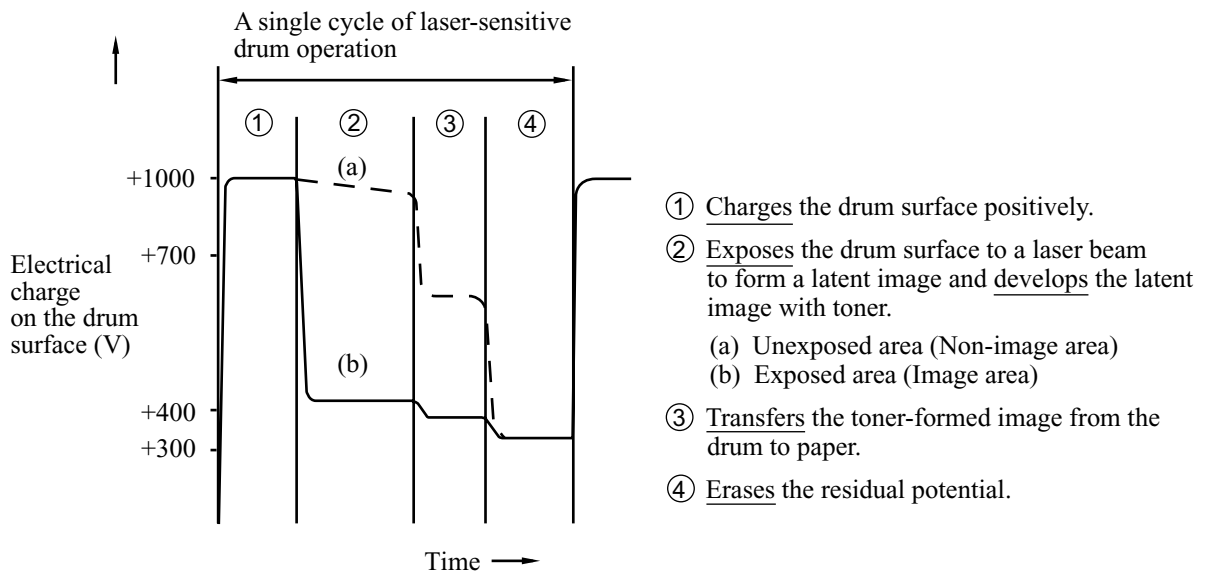

3.2.2.3 Heat-fixing mechanism

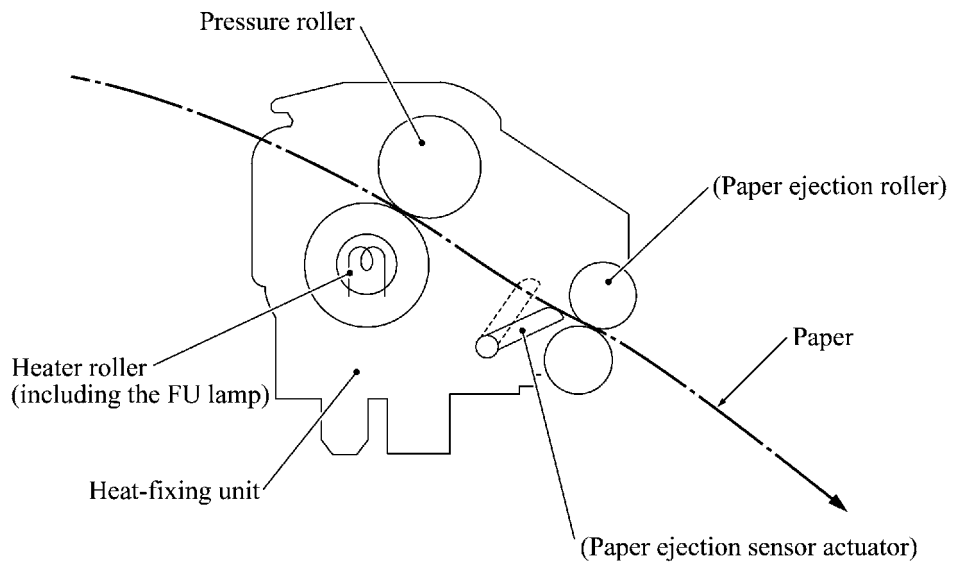

As the paper passes between the heater roller and the pressure roller in the heat-fixing unit, the heater roller fuses the toner on the paper.

3.2.3 Sensors and Actuators

This machine has ten sensors: seven photosensors, two thermistors and a mechanical switch as described below.

Sensor name	Type	Located on
Document front sensor	Photosensor	Document sensor PCB in the ADF
Document rear sensor	Photosensor	
Document tray open sensor	Mechanical switch	Document tray
Scanner open sensor	Photosensor	Control panel PCB
Registration sensor	Photosensor	Main-fan PCB
Paper ejection sensor	Photosensor	High-voltage power supply PCB
CCD HP sensor	Photosensor	CCD PCB on the CCD unit
Toner sensor	Photosensor	Toner sensor PCB
Toner thermistor	Thermistor	
Heater thermistor	Thermistor	Heat-fixing unit

- Document front sensor which detects the presence of documents.
- Document rear sensor which detects the leading and trailing edges of pages to tell the control circuitry when the leading edge of a new page has reached the starting position and when the scan for that page is over.
- Document tray open sensor which detects whether the document tray is closed.
- Scanner open sensor which detects whether the scanner unit is closed.
- Registration sensor which detects the leading and trailing edges of paper, which allows the controller to determine the registration timing and check paper jam.
- Paper ejection sensor which detects whether the recording paper goes out of the machine.
- CCD HP sensor which detects whether the CCD unit is placed in the home position.
- Toner sensor which detects whether there is toner or a toner cartridge is loaded.
- Toner thermistor which allows the controller to monitor the ambient temperature of the toner cartridge.
- Heater thermistor which allows the controller to monitor the temperature of the heater roller of the fixing unit.

These photosensors are a photointerrupter consisting of a light-emitting diode and a light-sensitive transistor. Each of them has an actuator separately arranged as shown on the next page.

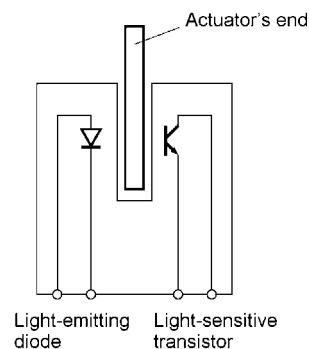

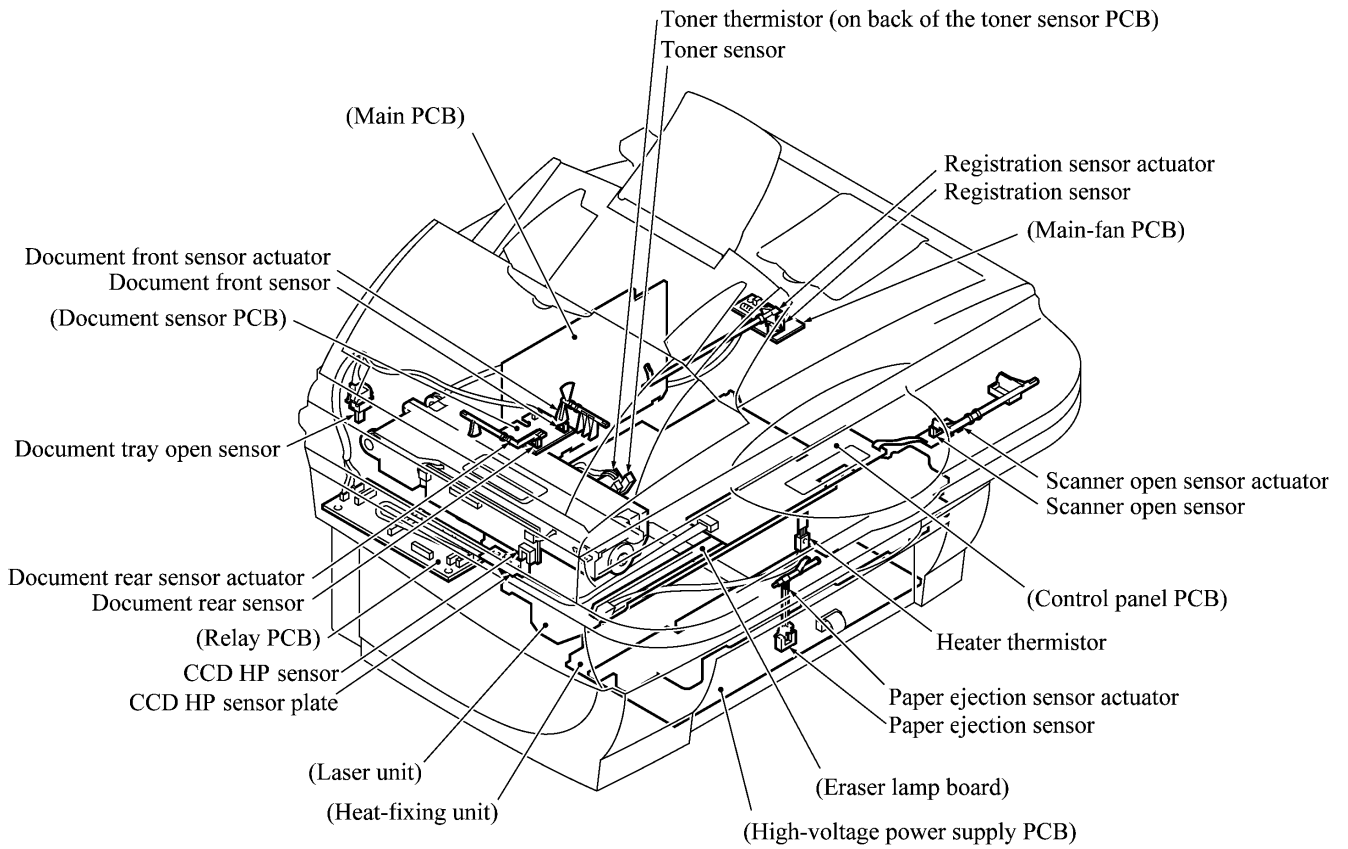

Location of Sensors and Actuators

3.3 CONTROL ELECTRONICS

3.3.1 Configuration

The hardware configuration of the facsimile machine is shown below.

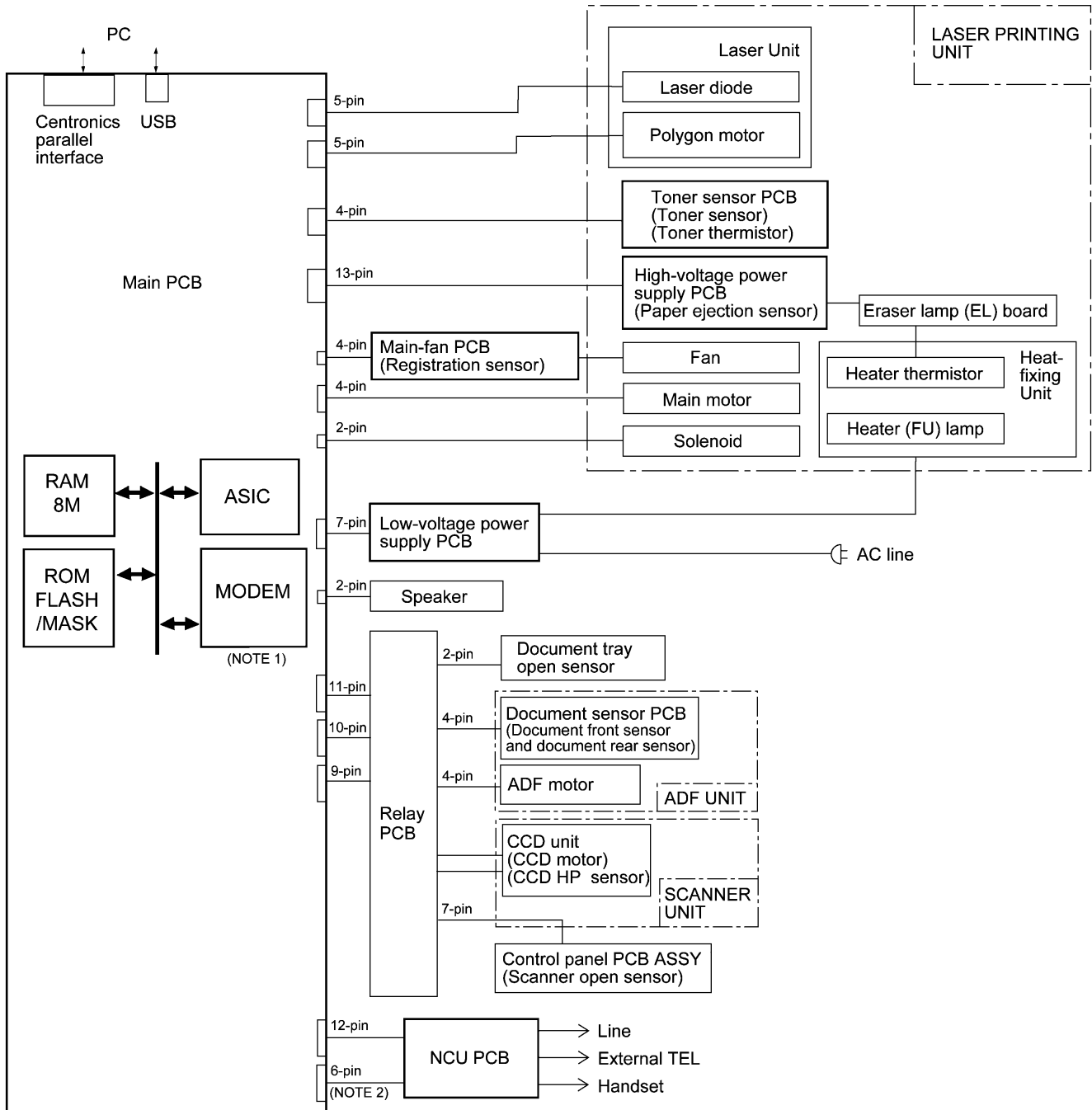

Configuration of Facsimile Machine

(NOTE 1) Provided on models equipped with facsimile function.

(NOTE 2) Provided on the European, Pacific, and Asian versions.

CHAPTER 4

DISASSEMBLY/REASSEMBLY AND LUBRICATION

CHAPTER 4 DISASSEMBLY/REASSEMBLY AND LUBRICATION

CONTENTS

4.1	DISASSEMBLY/REASSEMBLY	4-1
	■ Safety Precautions	4-1
	Tightening Torque List	4-2
	■ Preparation	4-4
	■ How to Access the Object Component	4-4
	■ Disassembly Order Flow	4-5
4.1.1	ADF Cover and Document Guide Base	4-6
4.1.2	ADF Components on the Upper ADF Chute	4-7
4.1.3	ADF Components on the Lower ADF Chute	4-12
4.1.4	Document Tray Open Sensor and Document Stopper	4-17
4.1.5	Scanner Unit and Control Panel ASSY (Together with Document Tray)	4-18
4.1.6	Disassembly of the Control Panel ASSY	4-25
4.1.7	Disassembly of the Scanner Unit	4-26
4.1.8	Front Cover	4-31
4.1.9	Relay PCB	4-32
4.1.10	Scanner Mount	4-33
4.1.11	Board Access Cover and Auto Sheet Feeder (ASF)	4-34
4.1.12	Heat-fixing Unit, FU Lamp, and Paper Ejection Sensor Actuator	4-40
4.1.13	Laser Unit and Toner Sensor PCB	4-42
4.1.14	Main PCB	4-43
4.1.15	Bottom Plate	4-46
4.1.16	Low-voltage Power Supply PCB	4-47
4.1.17	High-voltage Power Supply PCB	4-48
4.1.18	Main-Fan PCB, Duct, and Fan	4-49
4.1.19	Power Supply Shield	4-50
4.1.20	Speaker	4-51
4.1.21	Gear Drive Unit	4-52

4.1.22	PCB Support and NCU PCB	4-54
4.1.23	Scanner Grounding Plate	4-55
4.1.24	EL (Eraser Lamp) Board	4-56
4.1.25	Harness Routing.....	4-57
4.1.26	Cleaning of High-voltage Contacts and Grounding Contacts.....	4-61
4.2	LUBRICATION	4-62
4.3	PERIODICAL REPLACEMENT PARTS	4-64
4.4	MTBF/MTTR	4-65

4.1 DISASSEMBLY/REASSEMBLY

■ Safety Precautions

To prevent the creation of secondary problems by mishandling, observe the following precautions during maintenance work.

- (1) Unplug the power cord from the power outlet before replacing parts or units. When having access to the power supply, be sure to unplug the power cord from the power outlet.
- (2) When servicing the optical system of the laser printing unit, be careful not to place screwdrivers or other reflective objects in the path of the laser beam. Be sure to take off any personal accessories such as wrist watches and rings before working on the printer. A reflected beam, though invisible, can permanently damage your eyes.
- (3) If the machine has been printing, allow the heat-fixing unit sufficient time to cool down before starting maintenance jobs. It is HOT!
- (4) Be careful not to lose screws, washers, or other parts removed for parts replacement.
- (5) Do not remove gears from the document feed roller ASSY or ejection roller ASSY if at all possible. Once removed, they will become unusable and new gears will have to be put back in.
- (6) When using soldering irons and other heat-generating tools, take care not to damage the resin parts such as wires, PCBs, and covers.
- (7) Before handling the PCBs, touch a metal portion of the machine to discharge static electricity; otherwise, the electronic parts may be damaged due to the electricity charged in your body.
- (8) When transporting PCBs, be sure to wrap them in conductive sheets such as aluminum foil.
- (9) Be sure to reinsert self-tapping screws correctly, if removed.
- (10) Tighten screws to the torque values listed on the next page.
- (11) When connecting or disconnecting cable connectors, hold the connector bodies not the cables. If the connector has a lock, always slide the connector lock to unlock it.
- (12) Before reassembly, apply the specified lubricant to the specified points. (Refer to Subsection 4.2 in this chapter.)
- (13) After repairs, check not only the repaired portion but also that the connectors and other related portions function properly before operation checks.

Tightening Torque List

Location	Screw type	Q'ty	Tightening torque N•m (kgf•cm)	
ADF thickness adjuster	Taptite, pan B M3x6	1	0.39 ±0.10	(4 ±1)
Upper ADF chute	Taptite, cup B M3x10	2	0.69 ±0.10	(7 ±1)
Lower ADF chute	Taptite, cup B M3x10	2	0.69 ±0.10	(7 ±1)
Grounding wire	Taptite, cup B M3x10	1	0.69 ±0.10	(7 ±1)
ADF drive unit	Taptite, cup B M3x8	2	0.69 ±0.10	(7 ±1)
ADF motor	Screw, pan (s/p washer) M3x6	1	0.69 ±0.10	(7 ±1)
Grounding wire on the scanner mount	Taptite, cup B M3x10	1	0.39 ±0.10	(4 ±1)
Document tray	Taptite, bind B M4x12	2	0.98 ±0.20	(10 ±2)
Hinge base R	Taptite, cup B M3x10	3	0.69 ±0.10	(7 ±1)
Hinge L	Taptite, cup B M3x10	3	0.69 ±0.10	(7 ±1)
Control panel ASSY	Taptite, cup B M3x12	6	0.39 ±0.10	(4 ±1)
Scanner open sensor PCB	Taptite, cup B M3x8	1	0.39 ±0.10	(4 ±1)
Reinforcement plate	Taptite, cup B M3x6	7	0.39 ±0.10	(4 ±1)
Control panel PCB	Taptite, cup B M3x6	2	0.39 ±0.10	(4 ±1)
Scanner top cover	Taptite, cup B M4x12	4	0.98 ±0.20	(10 ±2)
Guide plate	Taptite, cup B M3x8	3	0.69 ±0.10	(7 ±1)
CCD HP sensor plate	Taptite, cup B M3x8	1	0.69 ±0.10	(7 ±1)
Flat cable clamp	Taptite, cup B M3x8	2	0.69 ±0.10	(7 ±1)
Front cover guides	Taptite, cup B M3x10	2	0.69 ±0.10	(7 ±1)
Relay PCB	Taptite, cup B M3x10	2	0.39 ±0.10	(4 ±1)
Scanner mount	Taptite, bind B M4x12	2	0.98 ±0.20	(10 ±2)
Board access cover	Taptite, bind B M4x12	2	0.78 ±0.10	(8 ±1)
Release lever	Taptite, bind B M4x10	1	0.98 ±0.20	(10 ±2)
Grounding leaf spring R	Taptite, bind B M2.6x8	1	0.39 ±0.10	(4 ±1)
Grounding leaf spring L	Taptite, bind B M2.6x8	2	0.39 ±0.10	(4 ±1)
Heat-fixing unit	Taptite, cup B M4x16	2	0.98 ±0.20	(10 ±2)
Fixing unit upper cover	Taptite, bind B M3x12	2	0.69 ±0.20	(7 ±2)
Lock plate	Taptite, pan B M3x10	1	0.69 ±0.20	(7 ±2)
Fuse plate R	Screw, pan (washer) M2.6x6DA	1	0.39 ±0.10	(4 ±1)
Laser unit	Taptite, bind B M4x12	3	0.98 ±0.20	(10 ±2)
Main shield	Taptite, cup S M3x6	2	0.69 ±0.20	(7 ±2)
Parallel interface connector	Taptite, pan S M3x12	2	0.69 ±0.20	(7 ±2)
Main PCB	Taptite, cup S M3x6	2	0.69 ±0.20	(7 ±2)
Bottom plate	Taptite, bind B M4x12	5	0.98 ±0.20	(10 ±2)
	Taptite, cup S M3x6	4	0.69 ±0.20	(7 ±2)

Low-voltage power supply PCB (Low-voltage insulator sheet)	Taptite, cup S M3x6	2	0.69 ±0.20	(7 ±2)
Grounding wire	Screw, pan (washer) M4x8DB	1	0.39 ±0.20	(4 ±2)
Power inlet support	Taptite, cup S M3x6	1	0.69 ±0.20	(7 ±2)
High-voltage power supply PCB	Taptite, bind B M4x12	1	0.98 ±0.20	(10 ±2)
Duct	Taptite, bind B M4x12	2	0.98 ±0.20	(10 ±2)
Fan support	Taptite, cup B M3x8	1	0.49 ±0.20	(5 ±2)
Power supply shield	Taptite, cup S M3x6	2	0.69 ±0.20	(7 ±2)
Gear drive unit	Taptite, bind B M4x14	4	0.98 ±0.20	(10 ±2)
Main motor	Taptite, cup S M3x6	2	0.69 ±0.20	(7 ±2)
Gear support plate	Taptite, cup S M3x16	2	0.69 ±0.20	(7 ±2)
PCB support	Taptite, bind B M4x12	2	0.98 ±0.20	(10 ±2)
NCU shield	Taptite, cup S M3x6	2	0.69 ±0.20	(7 ±2)
NCU PCB	Taptite, cup S M3x6	1	0.69 ±0.20	(7 ±2)
Scanner grounding plate	Taptite, cup B M3x8	1	0.49 ±0.20	(5 ±2)

■ Preparation

Prior to proceeding to the disassembly procedure,

(1) Unplug

- the modular jack of the telephone line (only for models equipped with the fax function),
- the power cord,
- the modular jack of the curled cord (and remove the handset),
- the PC interface cable (parallel cable or USB cable) if connected (Not shown below), and
- the modular jack of an external telephone set if connected (Not shown below).

(2) Remove

- the paper support,
- the paper tray, and
- the drum unit (with the toner cartridge loaded)

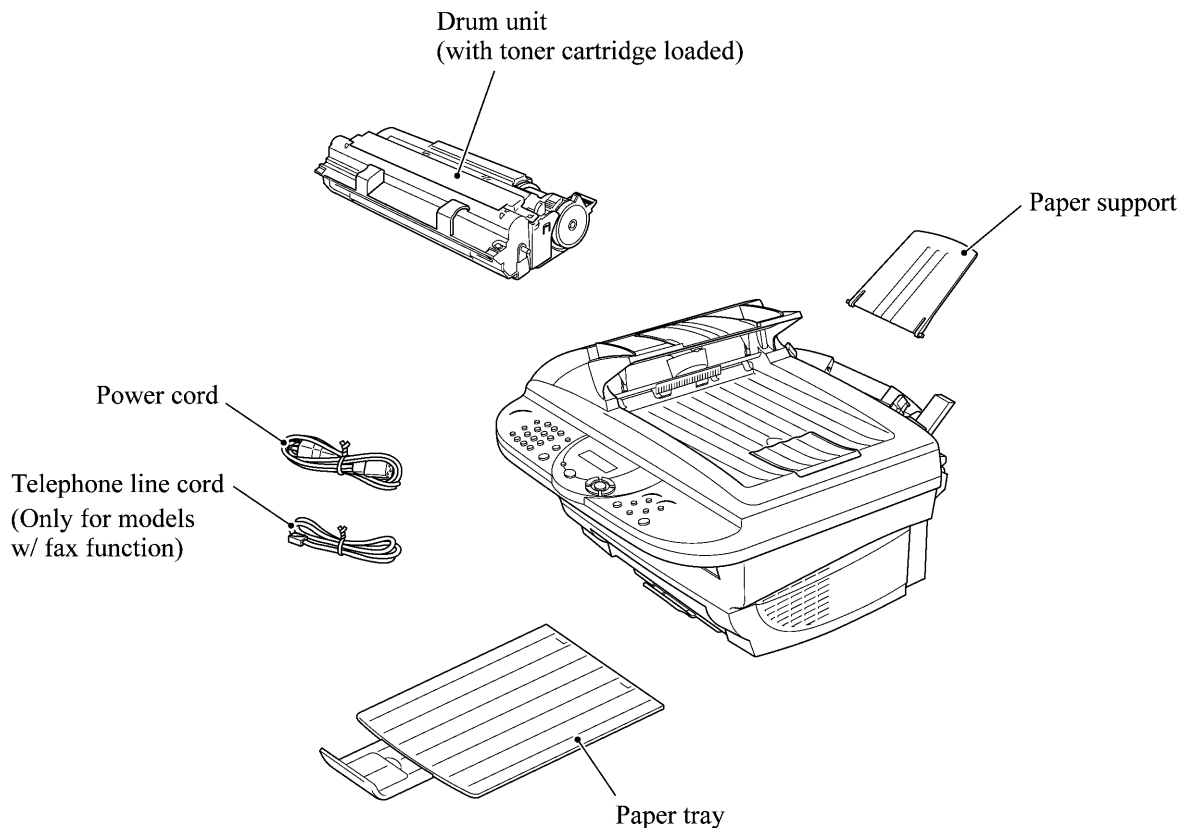

■ How to Access the Object Component

- On the next page is a disassembly order flow which helps you access the object components. To remove the gear drive unit, for example, first find it on the flow and learn its number (4.121 in this case). You need to remove parts numbered 4.15, 4.110, 4.111, 4.112, 4.115, 4.116, and 4.119 so as to access the gear drive unit.
- Unless otherwise specified, the disassembled parts or components should be reassembled in the reverse order of removal.

■ Disassembly Order Flow

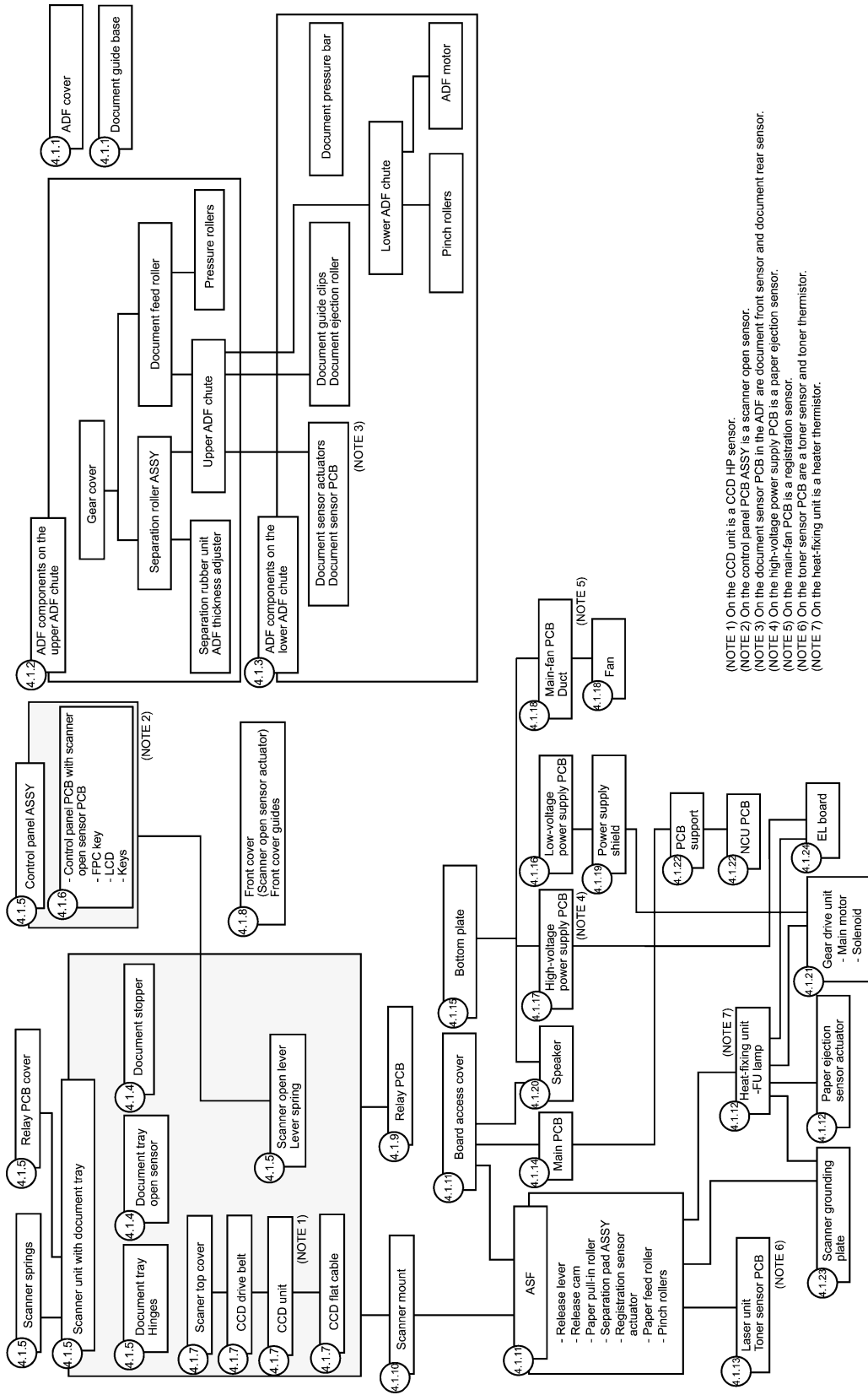

(NOTE 1) On the CCD unit is a CCD-HP sensor.
 (NOTE 2) On the control panel PCB ASSY is a scanner open sensor.
 (NOTE 3) On the document sensor PCB in the ADF are document front sensor and document rear sensor.
 (NOTE 4) On the high-voltage power supply PCB is a paper ejection sensor.
 (NOTE 5) On the main-fan PCB is a registration sensor.
 (NOTE 6) On the toner sensor PCB are a toner sensor and toner thermistor.
 (NOTE 7) On the heat-fixing unit is a heater thermistor.

4.1.1 ADF Cover and Document Guide Base

- (1) Open the ADF cover, press its front end to release the boss, and take it off (in the direction of arrows ①, ②, and ③).

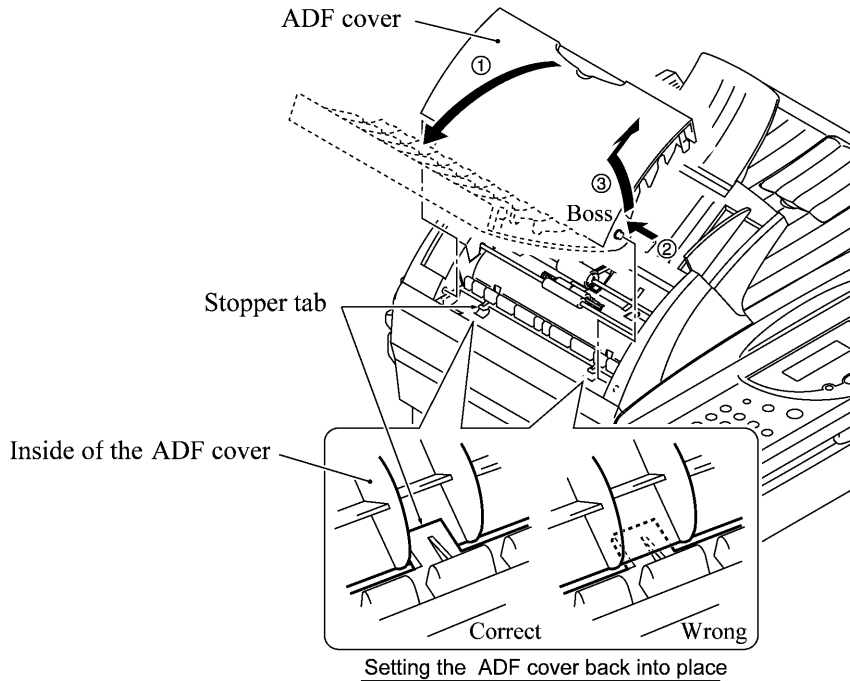

- (2) Release the two latches of the document guide base and slide it up *straight along the guides*.
NOTE: Do not turn it to the left. Doing so will break the groove sections of the document guide base.

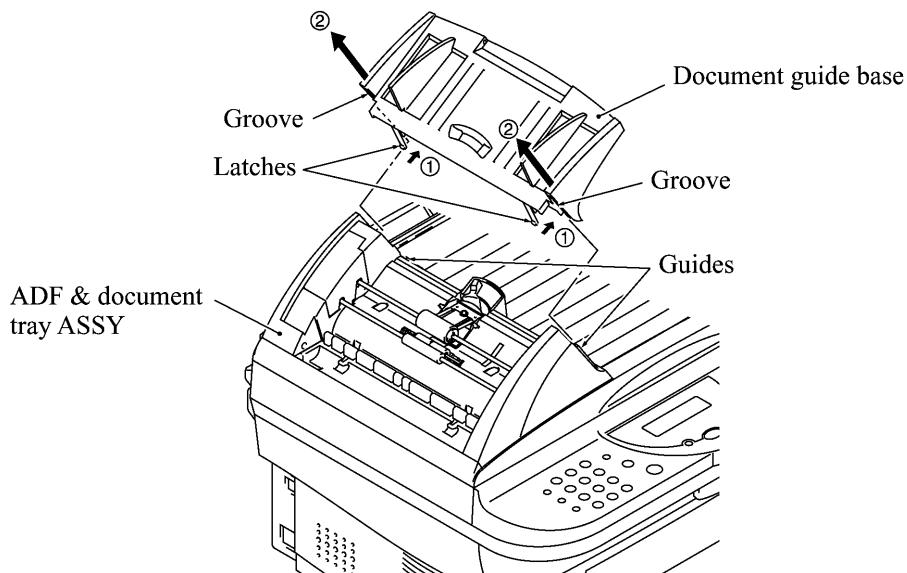

■ Reassembling Notes

- When setting the ADF cover back into place, fit its bottom edge under the stopper tabs as illustrated above.

4.1.2 ADF Components on the Upper ADF Chute

Gear cover

- (1) As illustrated below, insert the tip of a flat screwdriver into the slot and lift up the right edge of the gear cover (arrow ①) and move the gear cover to the front (arrow ②).

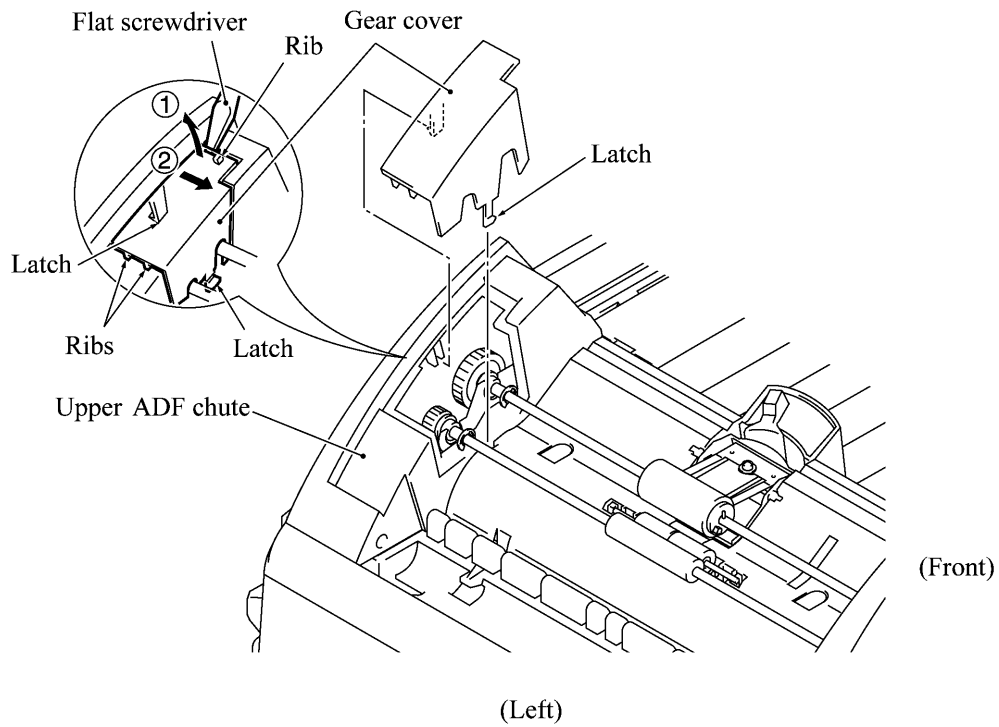

Separation roller ASSY and document feed roller

- (2) From the rear end of each of the separation roller ASSY and document feed roller, remove the plastic retaining ring. Lift up the rear ends of them and take them out together with bushings S.

NOTE: Take care not to drop bushings S.

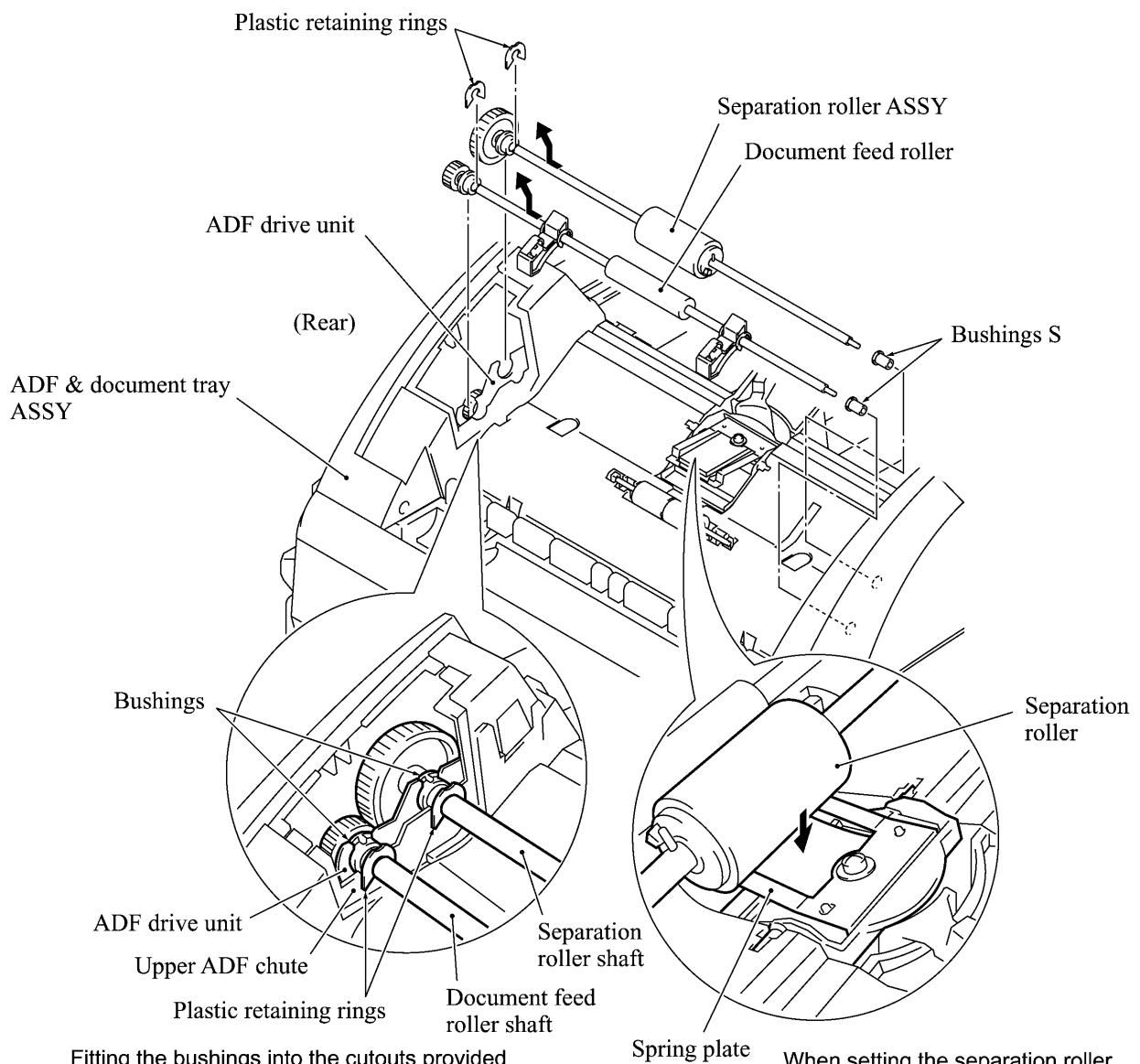

Fitting the bushings into the cutouts provided in the ADF drive unit and setting the plastic retaining rings inside the upper ADF chute

When setting the separation roller, take care not to apply force to the spring plate *at an angle*

Reassembling Note: If you have disassembled the separation roller ASSY, set the separation roller on its shaft with the boss facing towards the pin and then snap the plastic retaining ring into place, as illustrated below.

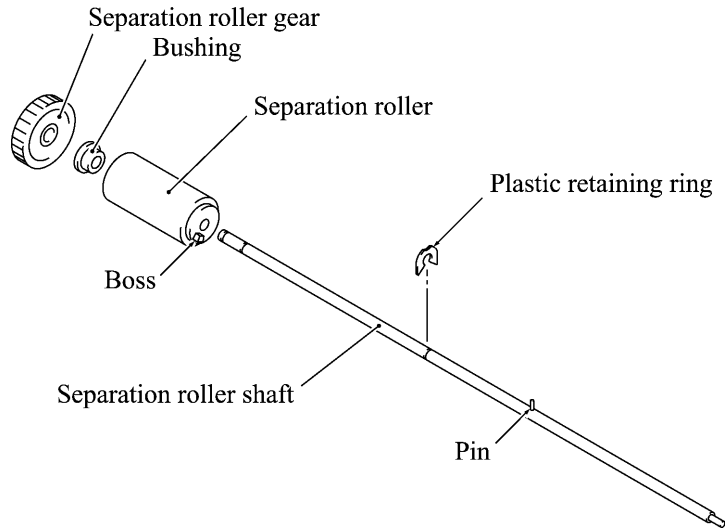

Reassembling Note: When setting the separation roller ASSY, take care not to apply force to the spring plate at an angle, as illustrated on the previous page.

Reassembling Note: After setting the rear end of the separation roller ASSY or document feed roller to the ADF drive unit, fit its bushing into the cutout provided in the ADF drive unit and then set the plastic retaining ring inside the upper ADF chute, as illustrated on the previous page.

Separation rubber unit, ADF thickness adjuster, and pressure rollers

- (3) Turn the separation rubber unit as shown below and lift it up.

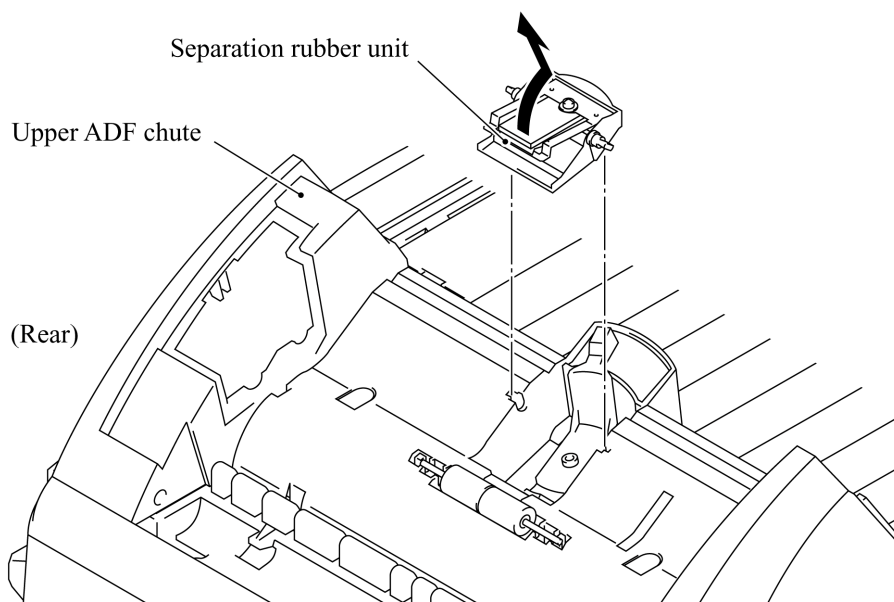

- (4) Remove the screw and take the ADF thickness adjuster out of the upper ADF chute.

NOTE: The ADF thickness adjuster is lubricated with grease, so take care not to smear surrounding parts with the grease when handing the ADF thickness adjuster.

- (5) At either end of the pressure roller shaft, press the latch to the right and take out the pressure rollers and their shaft. Then remove their springs.

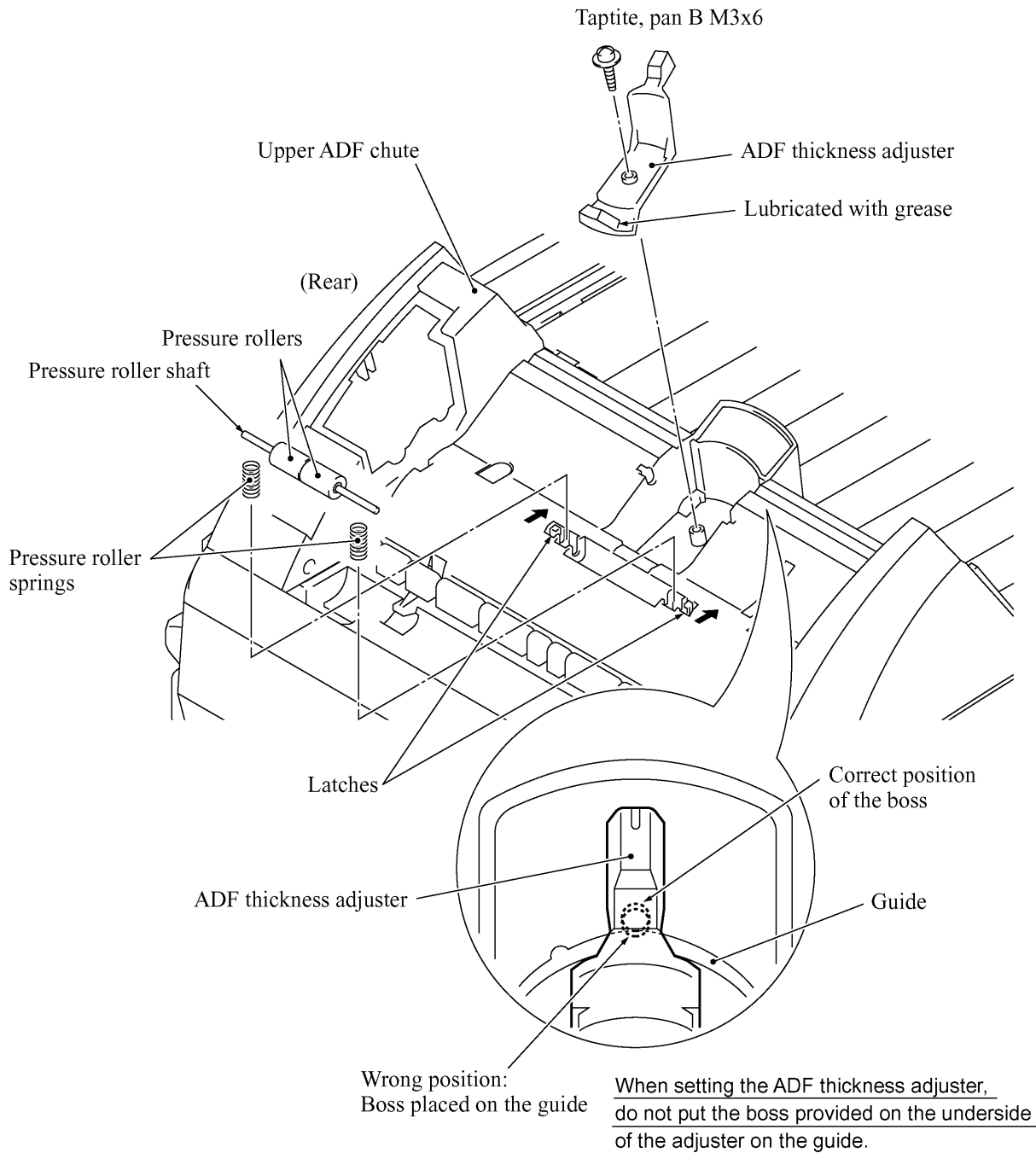

Upper ADF chute

- (6) Remove the two screws from the upper ADF chute.
- (7) Open the document tray (①).
- (8) From the underside of the document tray, release the two leftmost latches (②) and then pull up the left end of the upper ADF chute (③).

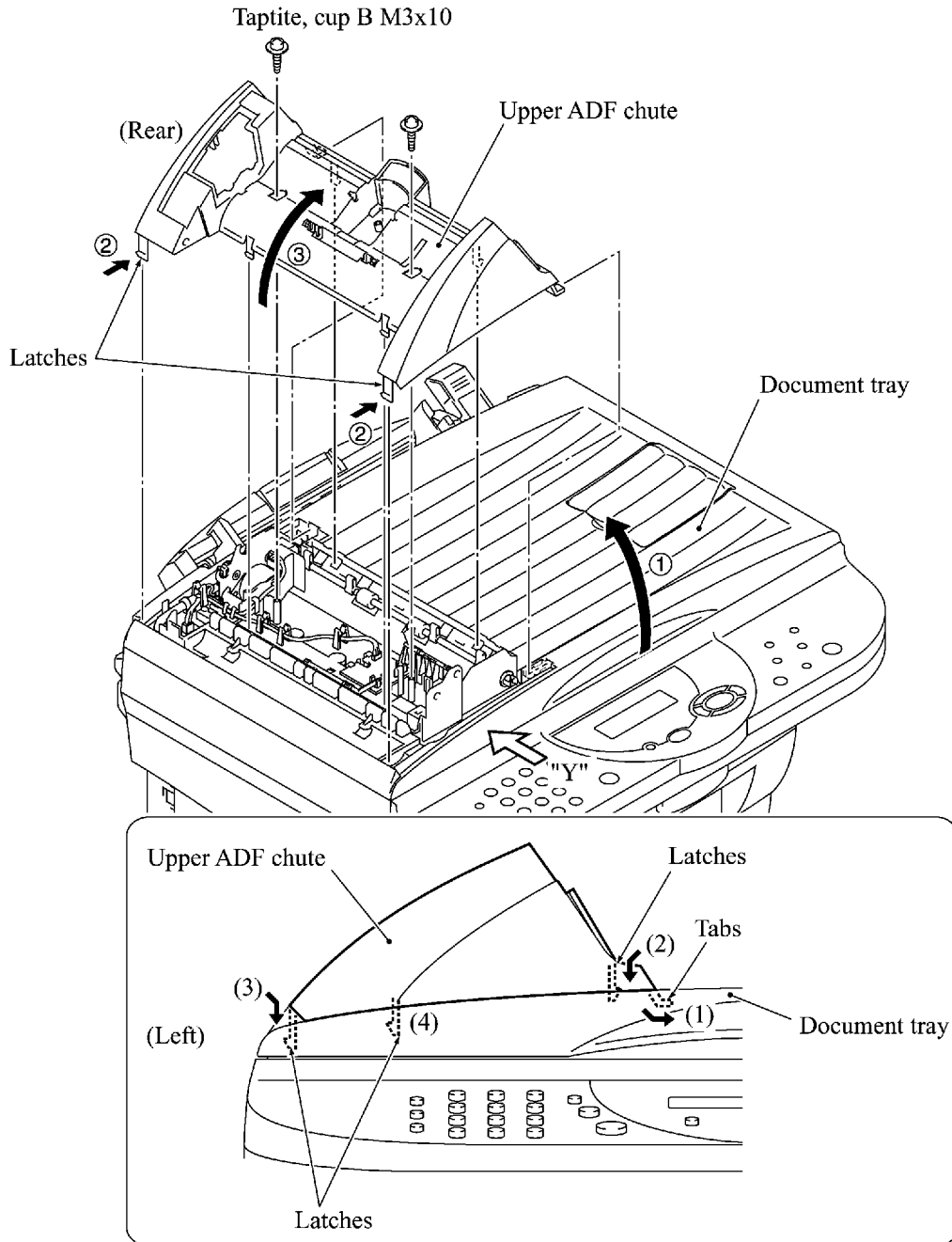

Latching the upper ADF chute (Viewed from "Y")

Reassembling Note: When latching the upper ADF chute, first fit tabs (1) of the right end into the openings provided in the document tray, then press latches (2), (3), and (4) into place in this order as shown above.

4.1.3 ADF Components on the Lower ADF Chute

Document front and rear sensor actuators

- (1) Lift up the document front sensor actuator. Fully turn the document rear sensor actuator counterclockwise, then lift it up.

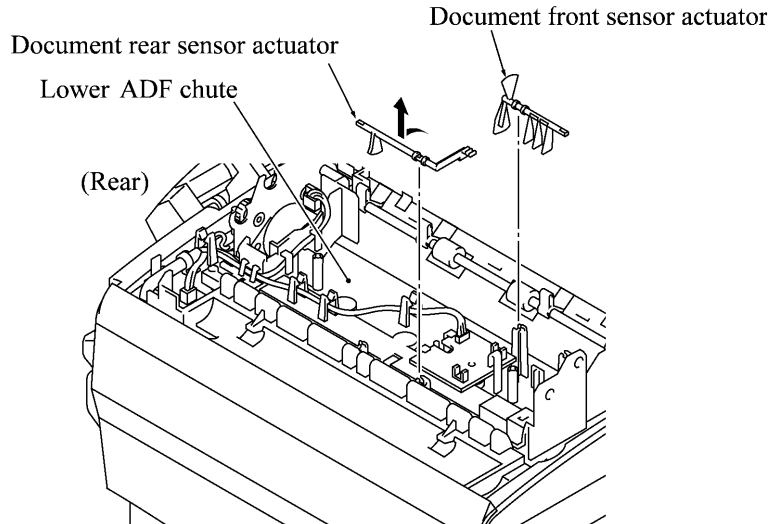

Document sensor PCB

- (2) Take the document sensor harness out of the cable hooks, then disconnect it from the document sensor PCB.
- (3) Press the locking pawl to the front and take out the document sensor PCB.

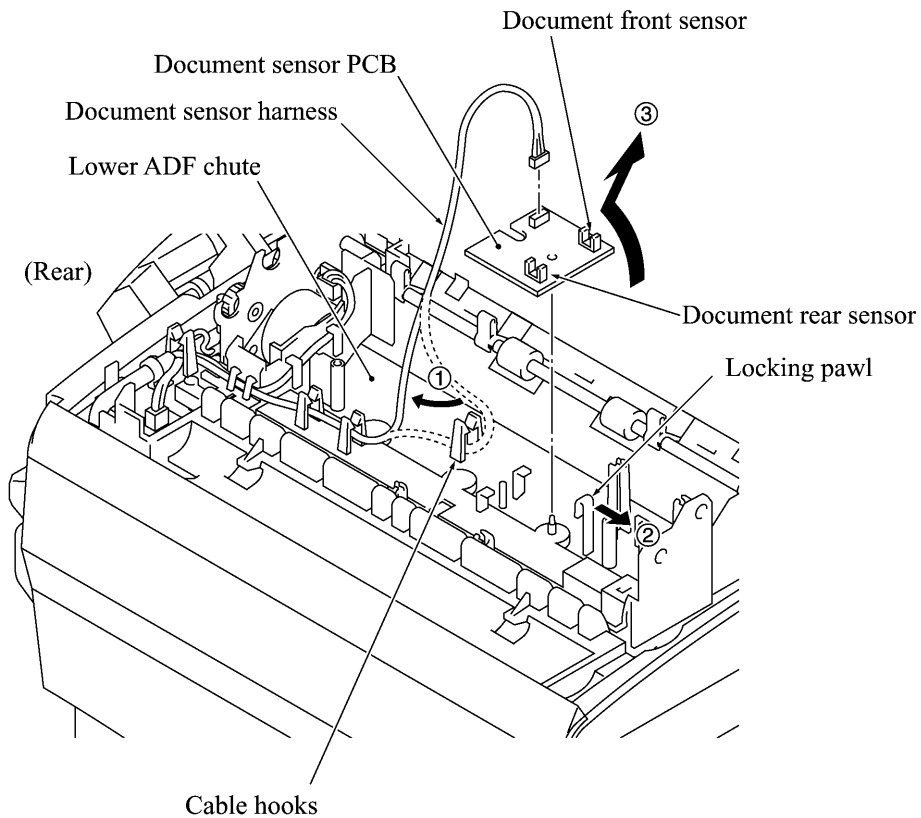

Document guide clips

- (4) Press the tab of each document guide clip. Each clip will snap out of the document ejection roller shaft.

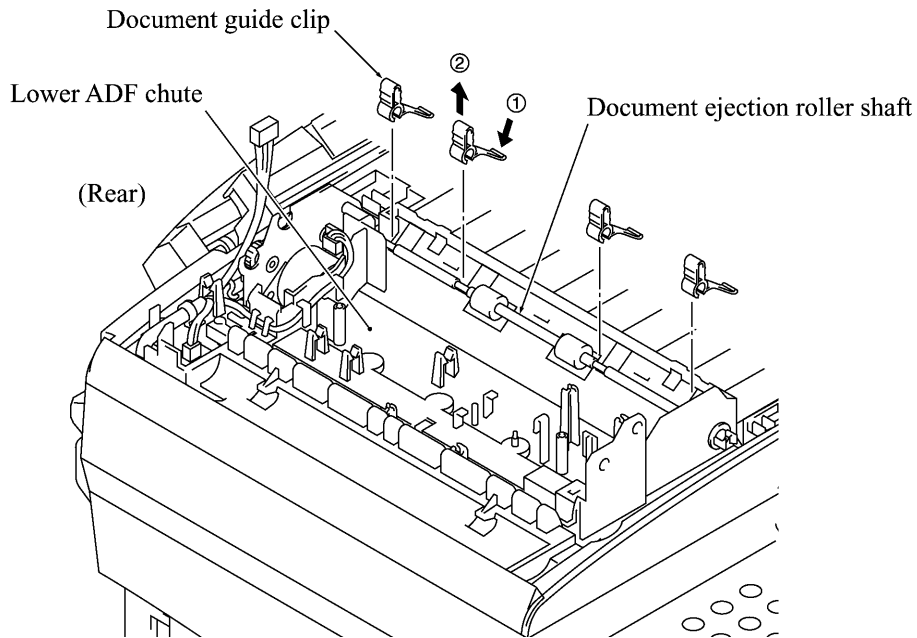

Document ejection roller

- (5) Remove the pawled bushing from the front end of the document ejection roller shaft by pulling its pawls outwards.
- (6) Slide the rear bushing to the rear and then lift up the document ejection roller.

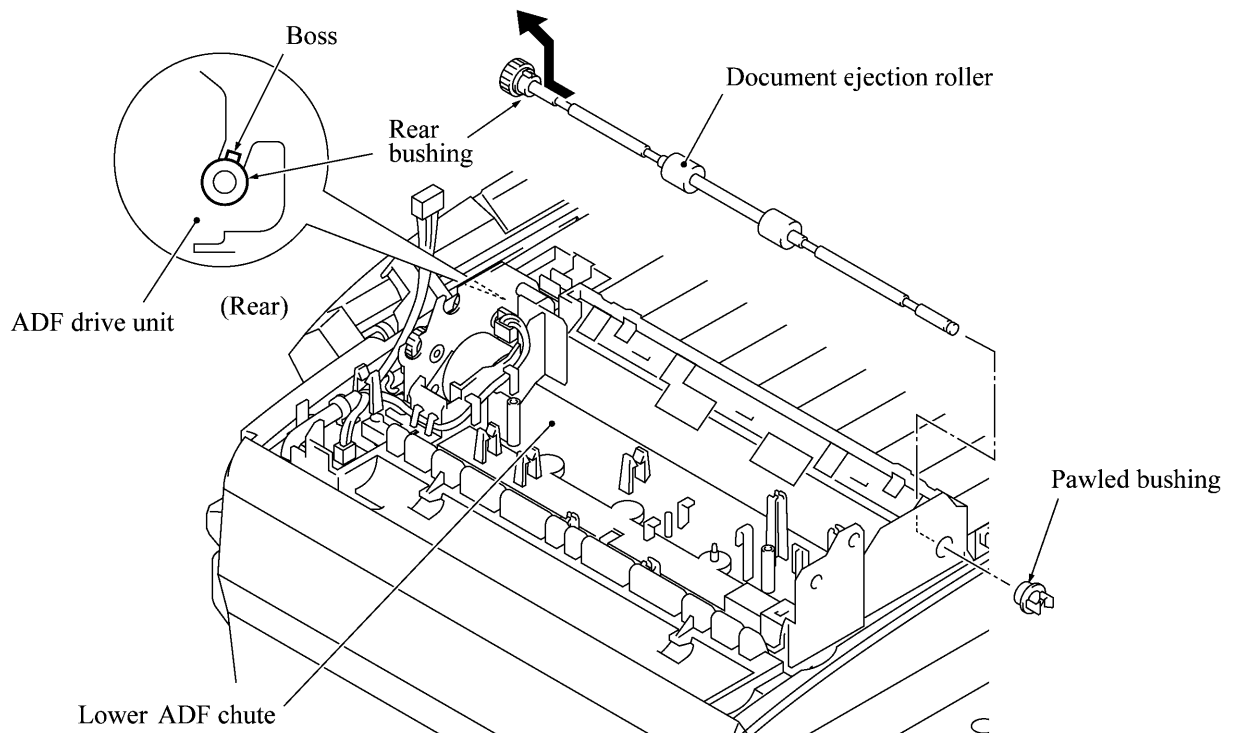

Reassembling Note: When fitting the rear bushing of the document ejection roller into the cutout of the ADF drive unit, orient the boss as illustrated on the previous page.

Document pressure bar

- (7) Open the ADF & document tray ASSY.
- (8) Pull either of the front and rear supports of the document pressure bar outwards and remove the document pressure bar. The spring also comes off.

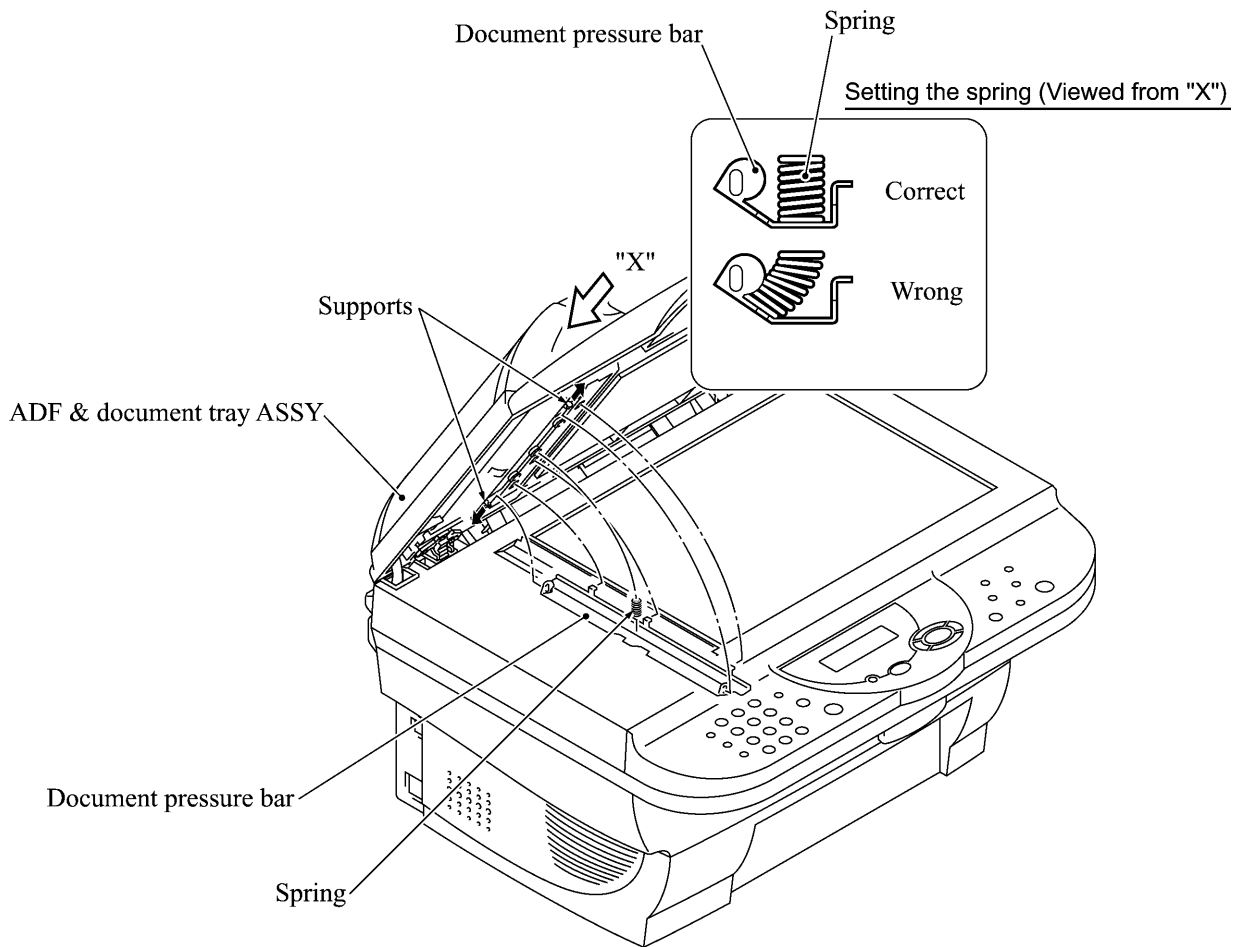

Reassembling Note: After setting the document pressure bar, check in the direction of arrow "X" that the spring is into place as illustrated above.

Lower ADF chute, pinch rollers, and ADF motor

- (9) Take the document sensor harness out of cable hooks provided on the lower ADF chute.
- (10) Disconnect the ADF motor harness from the motor, then take its harness out of the cable guides and hooks.
- (11) Release the grounding wire from the ADF drive unit by removing the screw.
- (12) Remove the two screws from the lower ADF chute.
- (13) Lift up the lower ADF chute in the direction of the arrow shown below, taking care not to touch the anti-static brush.
- (14) Press the latch to the left and remove the pinch rollers and its shaft.

When reinstalling the lower ADF chute, turn the planet gear counterclockwise (when viewed from the rear)

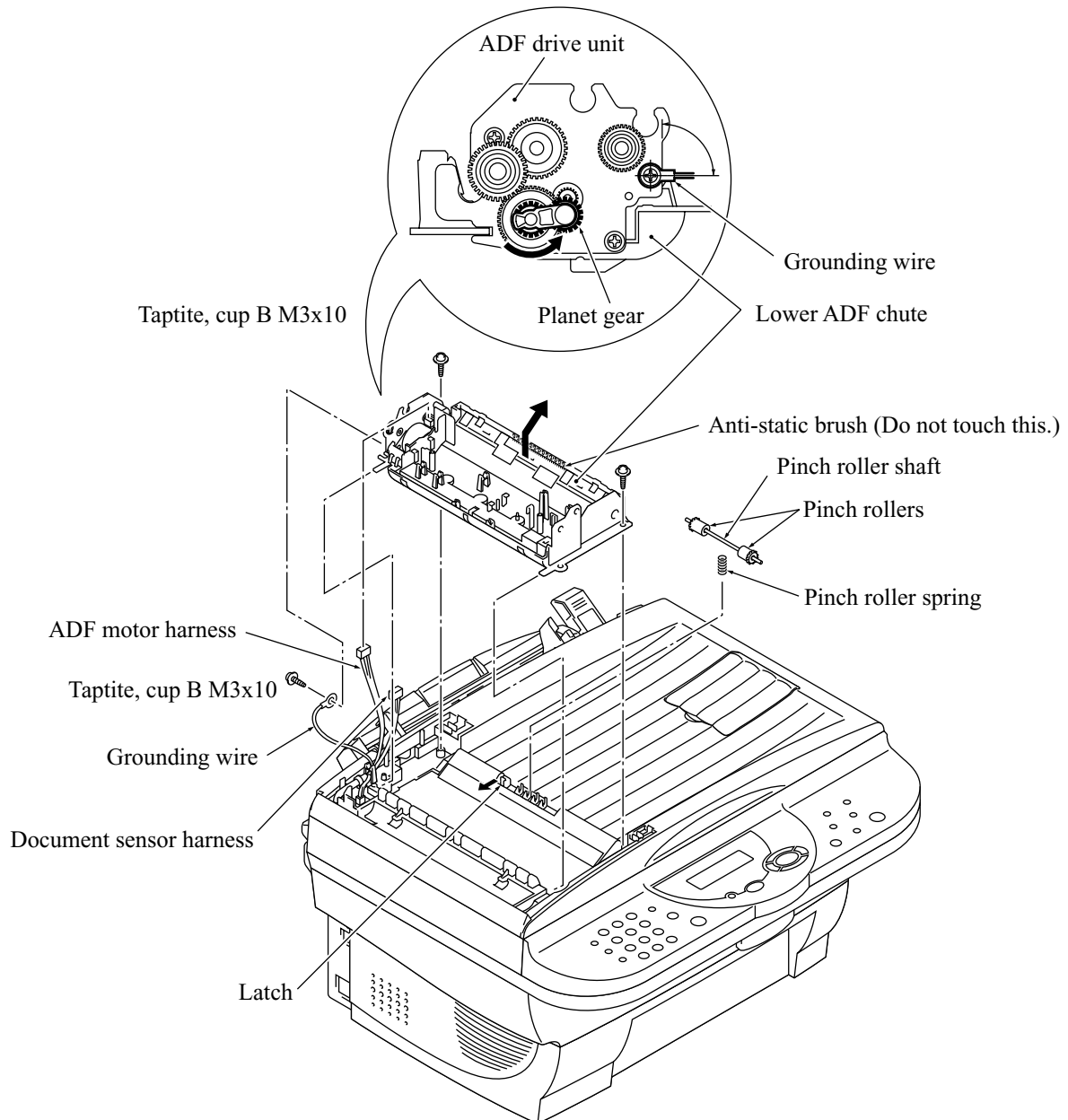

(15) Remove the two screws from the ADF drive unit and release the ADF motor.

NOTE: When using a screwdriver, take care not to scratch or damage gears on the ADF drive unit.

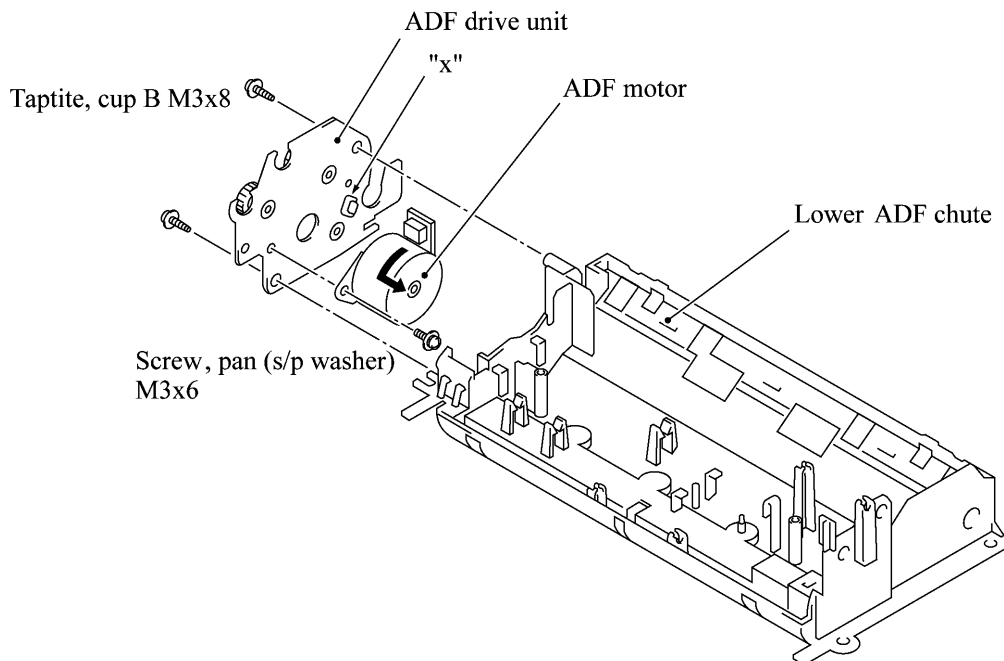

Reassembling Note: When setting the ADF motor, hook the non-screw side of the flange on section "x" (shown above) and secure it with the screw.

Reassembling Note: Before reinstalling the lower ADF chute to the document tray, be sure to turn the planet gear on the ADF drive unit counterclockwise when viewed from the rear, as illustrated on the previous page.

Reassembling Note: For routing the ADF motor harness, document sensor harness, and grounding wire, refer to Subsection 4.1.25, "Harness routing A." Secure the grounding wire at the angle shown on the previous page and let it hold down the ADF motor harness and document sensor harness as shown in "Harness routing A."

4.1.4 Document Tray Open Sensor and Document Stopper

- (1) Disconnect the document tray open sensor harness from the sensor.
- (2) Open the document tray.
- (3) Press the right and left latches of the document tray open sensor with the tip of a flat screwdriver as shown below and push it down.

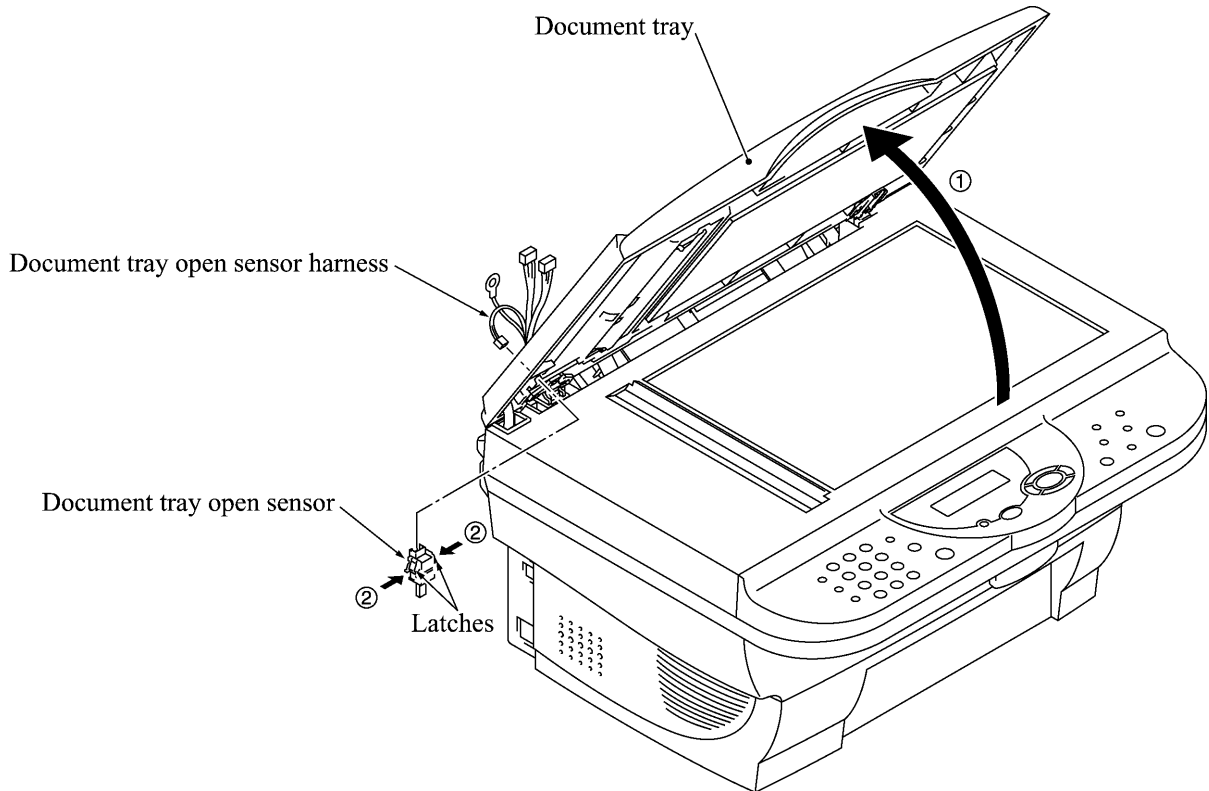

- (4) Slightly open the document stopper and remove it while warping it.

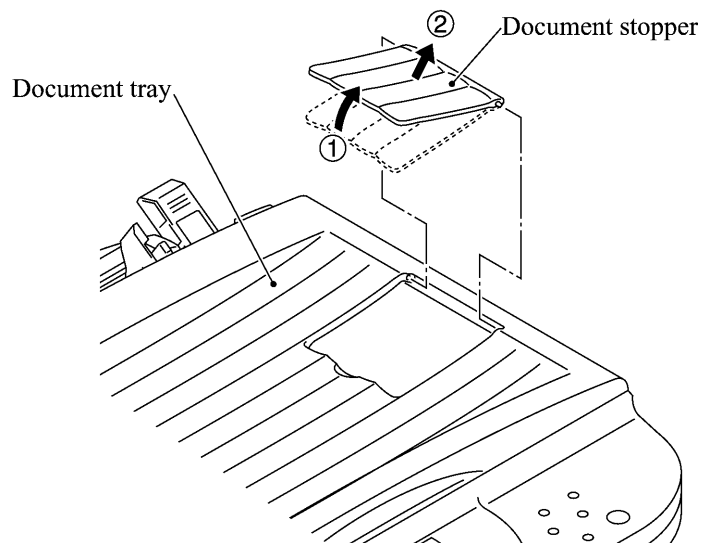

4.1.5 Scanner Unit and Control Panel ASSY (Together with Document Tray)

- (1) Pull the scanner open lever and open the scanner unit.
- (2) Unhook the two scanner springs. (The right-hand scanner spring is shorter than the left-hand one.)

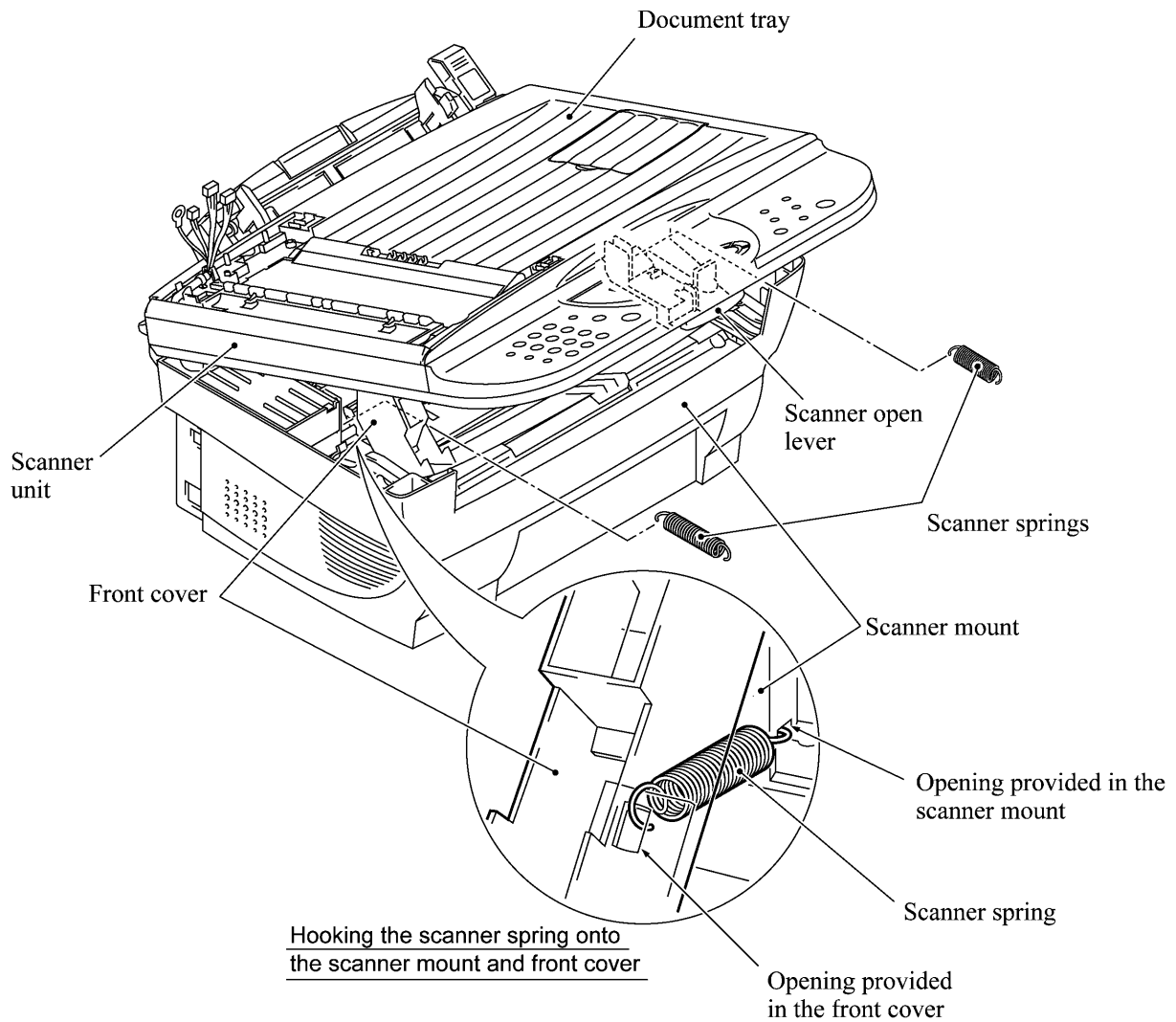

- (3) At each of the right and left rear edges of the front cover, push up the lock of the front cover connector (in the direction of arrow ①) and press the rear edge of the front cover inwards (arrow ②) to release its boss from the front cover connector.

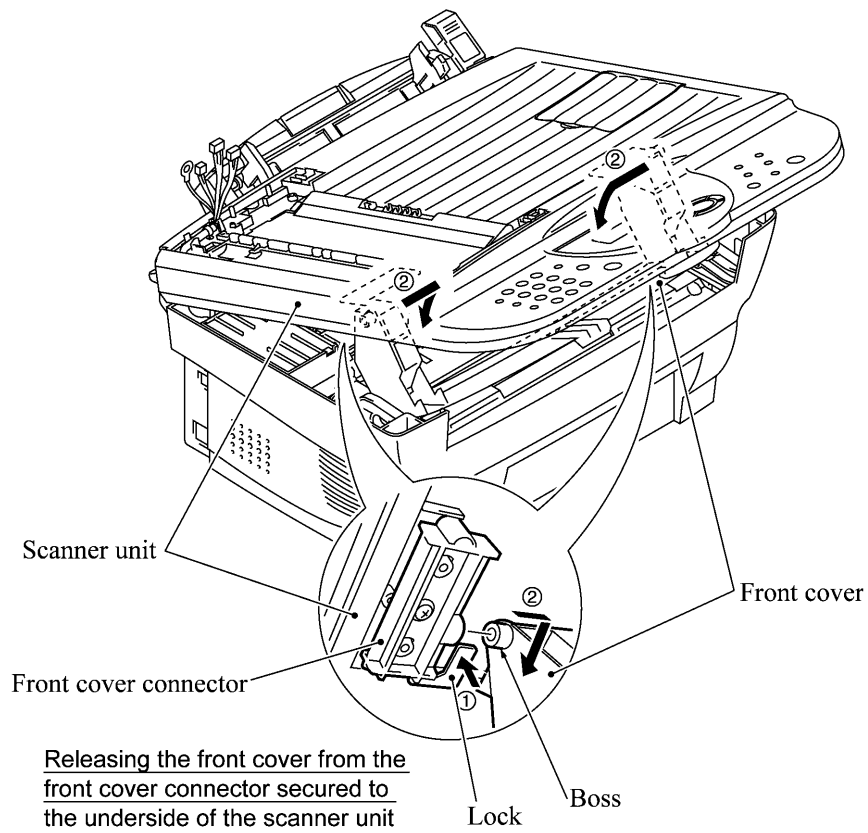

- (4) While keeping the scanner unit open, unlatch the relay PCB cover and take it out.

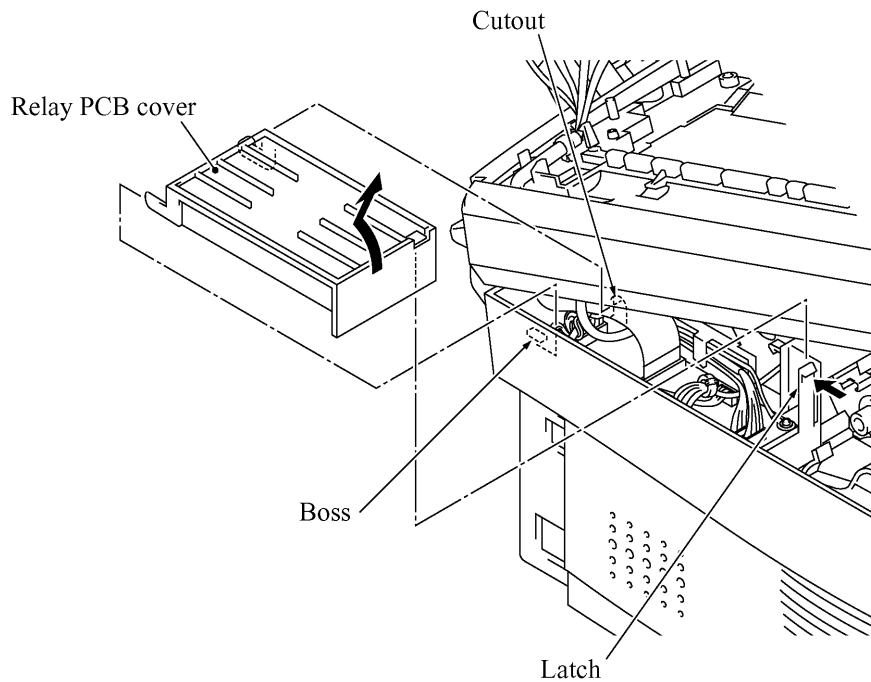

- (5) While keeping the scanner unit open (in the direction of arrow ①), disconnect the CCD flat cable (arrow ②) from the relay PCB.

NOTE: Handle the CCD flat cable with care.

- (6) Open the scanner unit further and lift up its rear edge to disengage it from the scanner mount. Then shift the scanner unit to the front right as shown below (arrow ③) so that the relay PCB can be fully seen.

CAUTION: When putting the scanner unit on the scanner mount, take special care not to bend, wrinkle, or scratch the CCD flat cable or not to break the boss of the front cover (that is provided for the scanner open sensor actuator) by the bottom of the scanner unit.

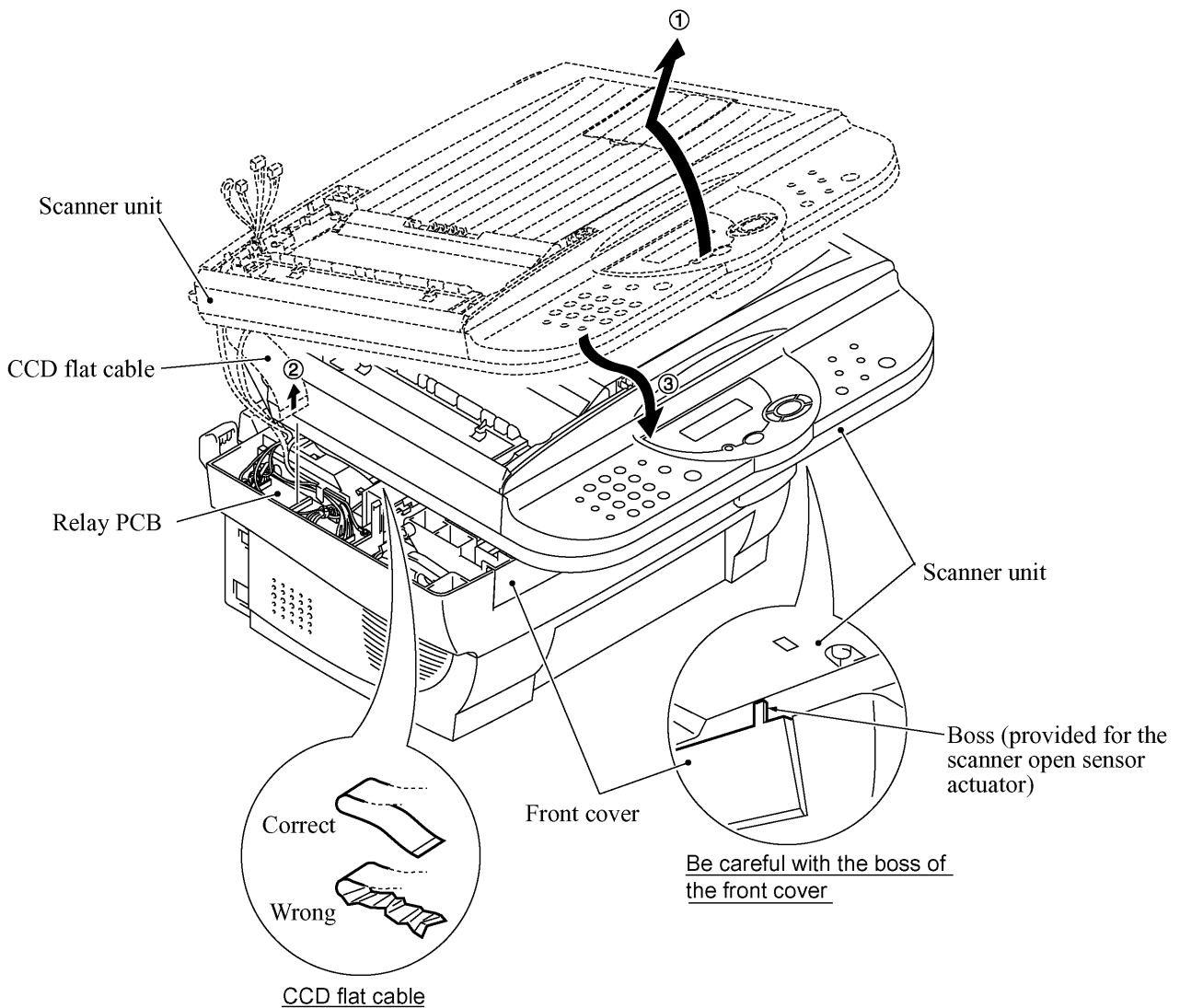

- (7) Disconnect the following harnesses from the relay PCB:
- Document tray open sensor harness
 - Document sensor harness
 - ADF motor harness
 - Panel harness
- (8) Release the grounding wire (coming from the ADF drive unit) by removing the screw.
- (9) Lift up the scanner unit together with the document tray and control panel ASSY.

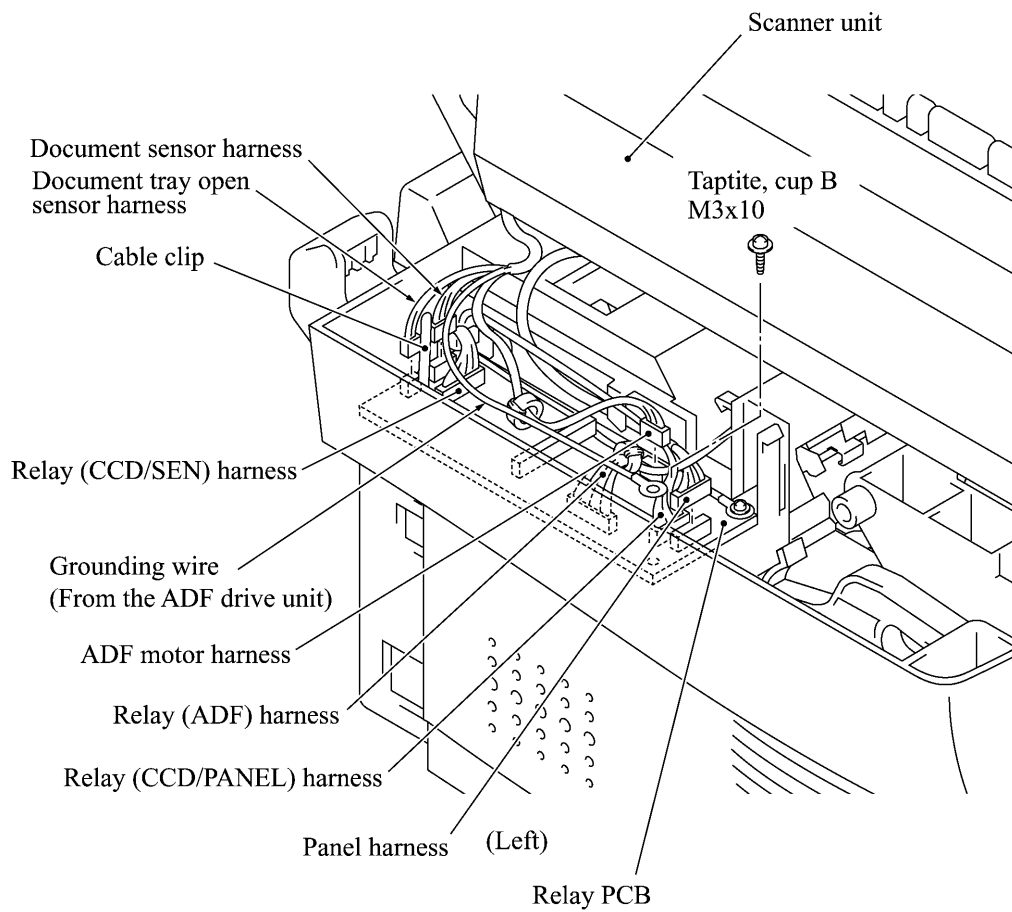

- (10) Remove the two screws from the bottom rear of the hinges.
- (11) Be sure to open the document tray, then release the harnesses (bound and covered with the cable sheath) from the latch and move them to the front in the opening.
- (12) Lift up the document tray.

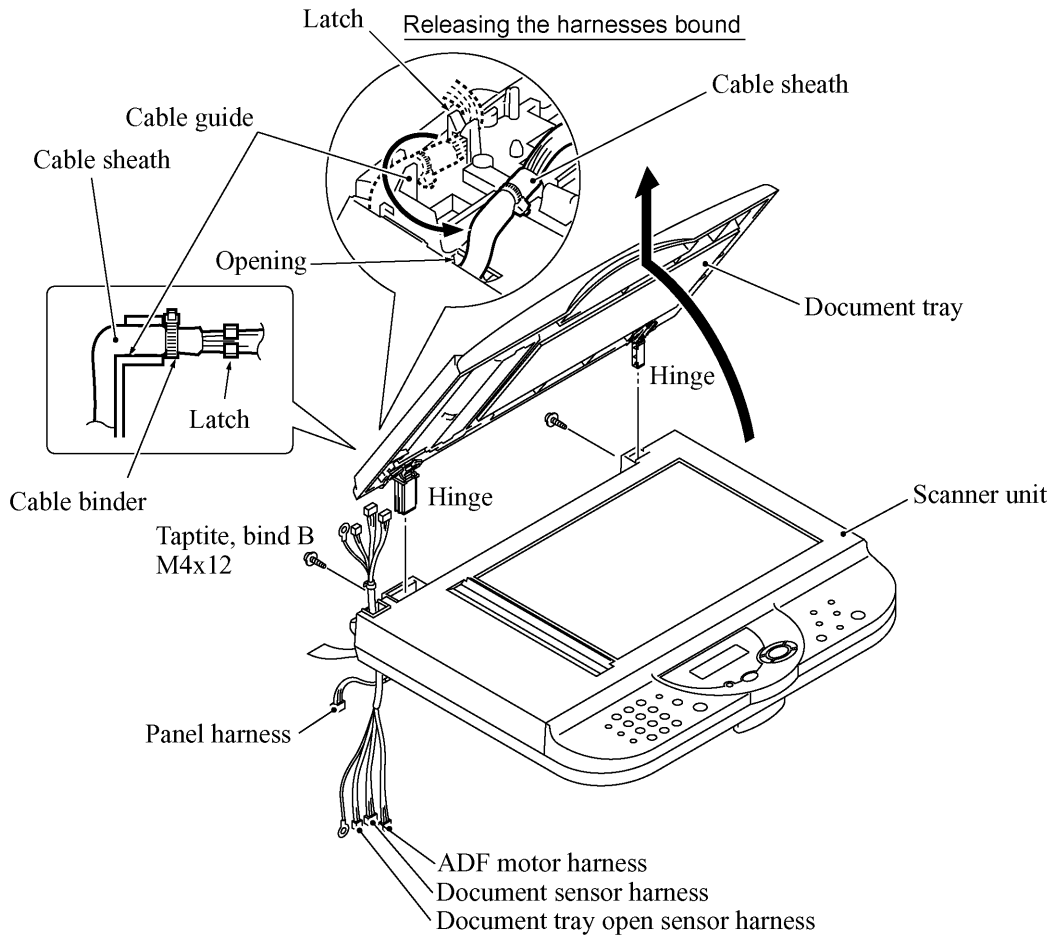

- (13) From the hinge base R, remove the hinge arm as shown below. Remove the three screws and release the hinge base R.
- (14) From the hinge L that should be kept opened, remove the three screws.

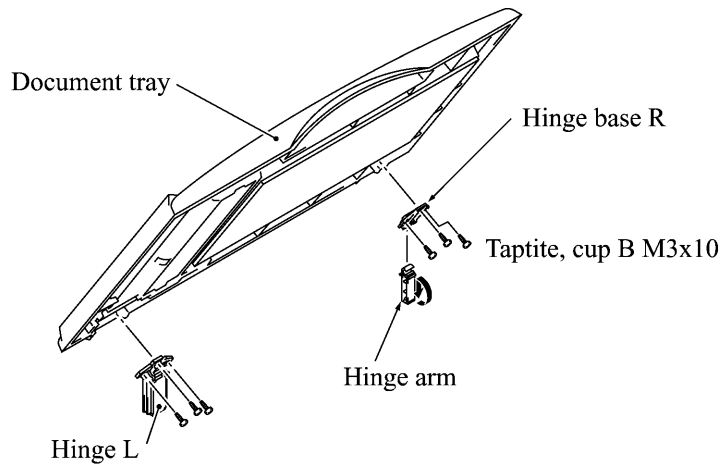

- (15) Remove the six screws from the underside of the scanner base.
- (16) Release the two latches of the control panel ASSY from the scanner base.
- (17) Slightly lift up the control panel ASSY and disconnect the panel harness from the control panel PCB.
- (18) Turn the scanner open sensor actuator as shown below and remove it.
- (19) Remove the screw from the scanner open sensor PCB. Then the control panel ASSY is separated from the scanner unit.
(For the disassembly procedure of the control panel ASSY and scanner unit, refer to Subsections 4.1.6 and 4.1.7, respectively.)
- (20) Remove the lever spring.
- (21) Insert the tip of a flat screwdriver into slit "s," push up the lock, and remove the scanner open lever in the direction of the arrow.

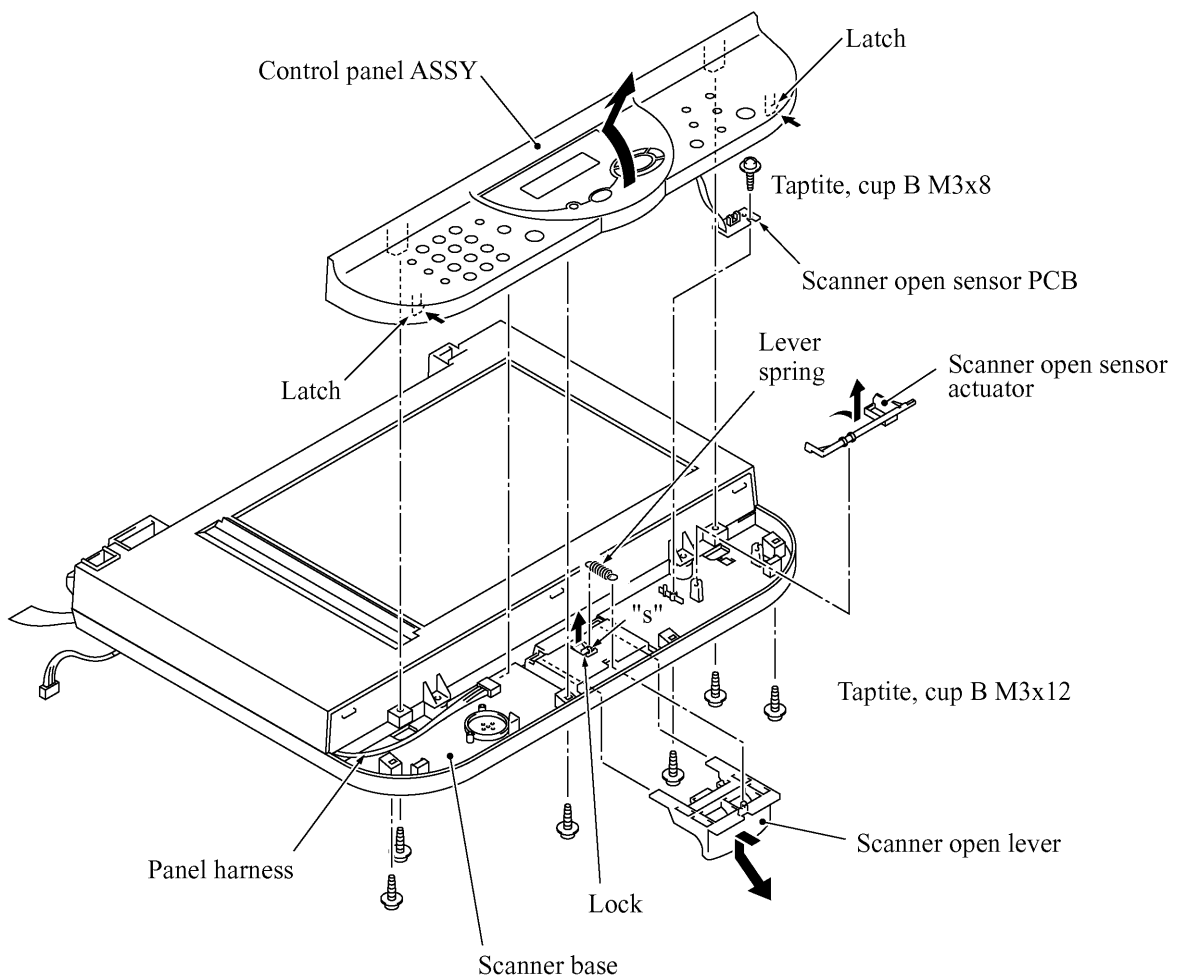

■ Reassembling Notes

- When setting the document tray on the scanner unit, pass the bound harnesses (ADF motor harness, document sensor harness, document tray open sensor harness, and grounding wire) through the front section of the opening provided in the left rear corner of the document tray, with its bound section facing up (see the illustration given on page 4-22).

Move those bound harnesses to the rear section of the opening. Route the bound section through the cable guide so that the cable binder comes into contact with the cable guide as illustrated on page 4-22. Refer to Subsection 4.1.25 "Harness routing A."

- When putting the scanner unit on the scanner mount, take special care not to bend, wrinkle, or scratch the CCD flat cable or not to break the boss of the front cover by the bottom of the scanner unit. (See the illustration given on page 4-20.)
- Route the document sensor harness, document tray open sensor harness, ADF motor harness, panel harness, and grounding wire on the scanner mount as shown on page 4-21. Wind the document sensor harness and document tray open sensor harness around the cable clip on the relay PCB, and then bend the cable clip as shown in Subsection 4.1.25, "Harness routing B."

4.1.6 Disassembly of the Control Panel ASSY

- (1) Remove the two screws from the control panel PCB.
- (2) Slightly lift up the control panel PCB, then unlock the FPC key connector and disconnect the FPC key. Next, unlock the LCD cable connector and disconnect the LCD flat cable.
- (3) Remove the seven screws and take off the reinforcement plate and FPC key.

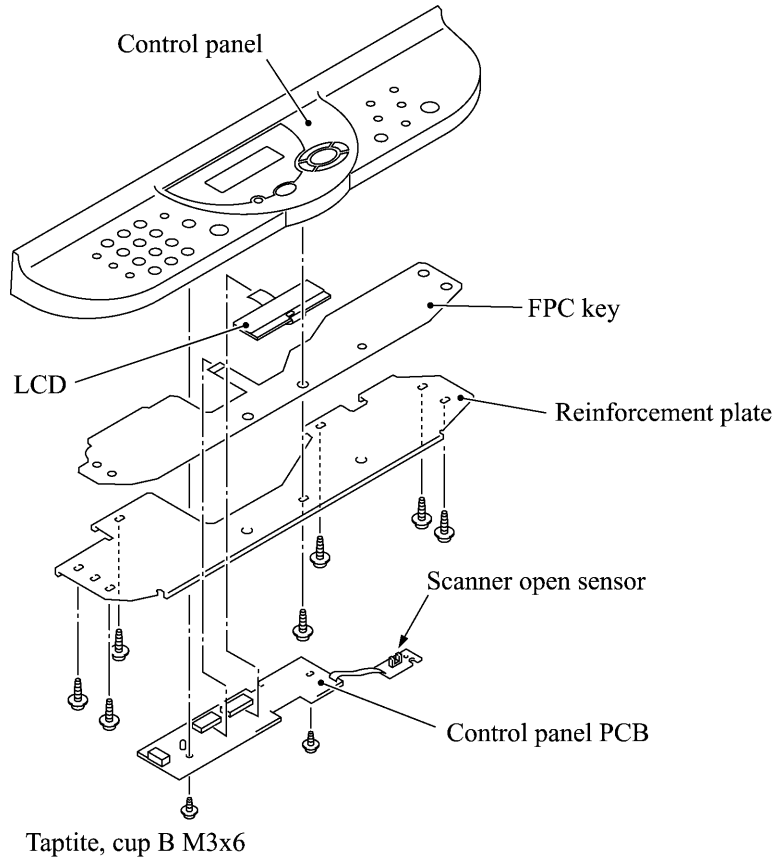

- (4) As shown below, pull the lock arms outwards to release the LCD and pull the LCD flat cable gently.

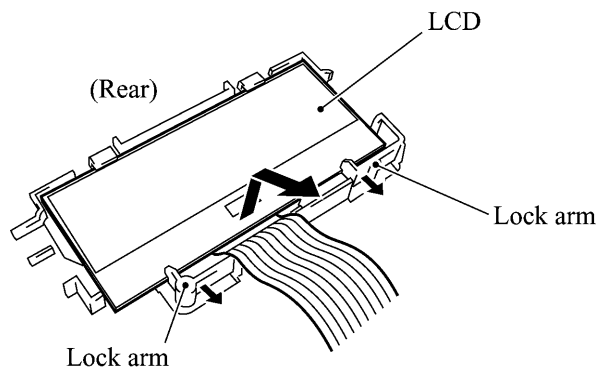

■ Reassembling Notes

- Before reinstalling the LCD to the control panel, wipe fingerprints or dust off the LCD surface and control panel window with a soft cloth.
- A new LCD is covered with a protection sheet. Before installing it, remove the protection sheet.

4.1.7 Disassembly of the Scanner Unit

The disassembly job of the scanner unit should be done in a clean room to prevent dust or dirt from getting into the scanner unit.

- (1) Remove the four screws from the scanner top cover.
- (2) Separate the scanner top cover from the scanner base.

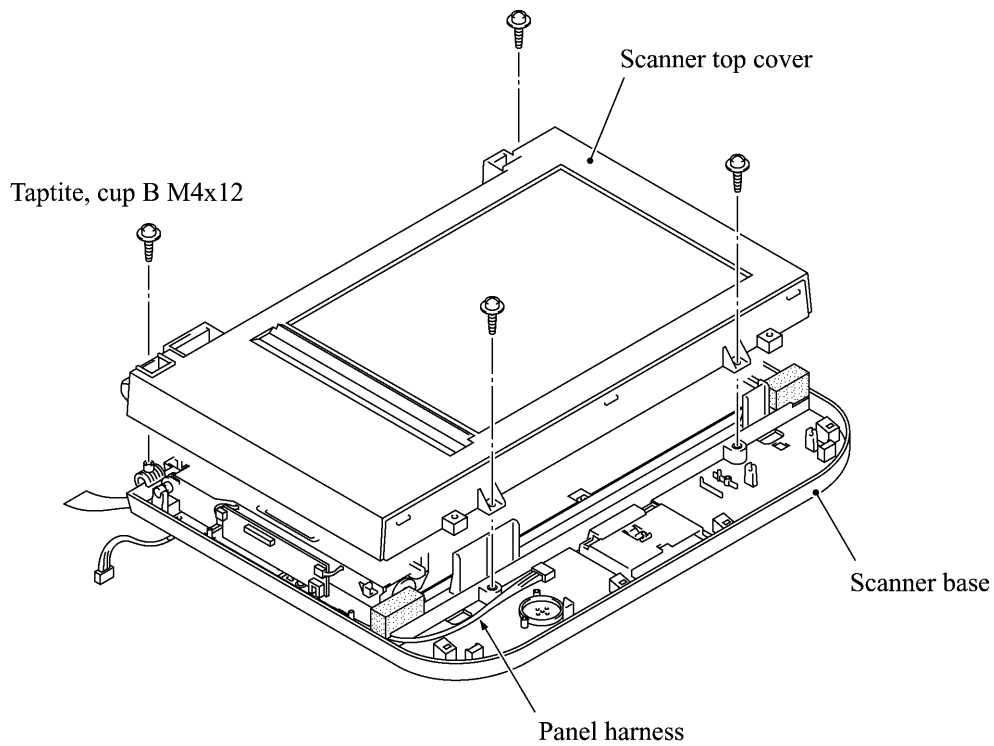

- (3) Release the CCD drive belt from boss "a."
 - (4) At the left front end of the CCD drive belt, unhook the belt spring from boss "b."
- NOTE:** Do not remove the belt spring or belt clip from the CCD drive belt.
- (5) As illustrated below, move the CCD unit to the right, lift up its front end and turn the CCD unit upright. The CCD drive belt will slip off the CCD idle pulley and gear on the underside of the CCD unit.

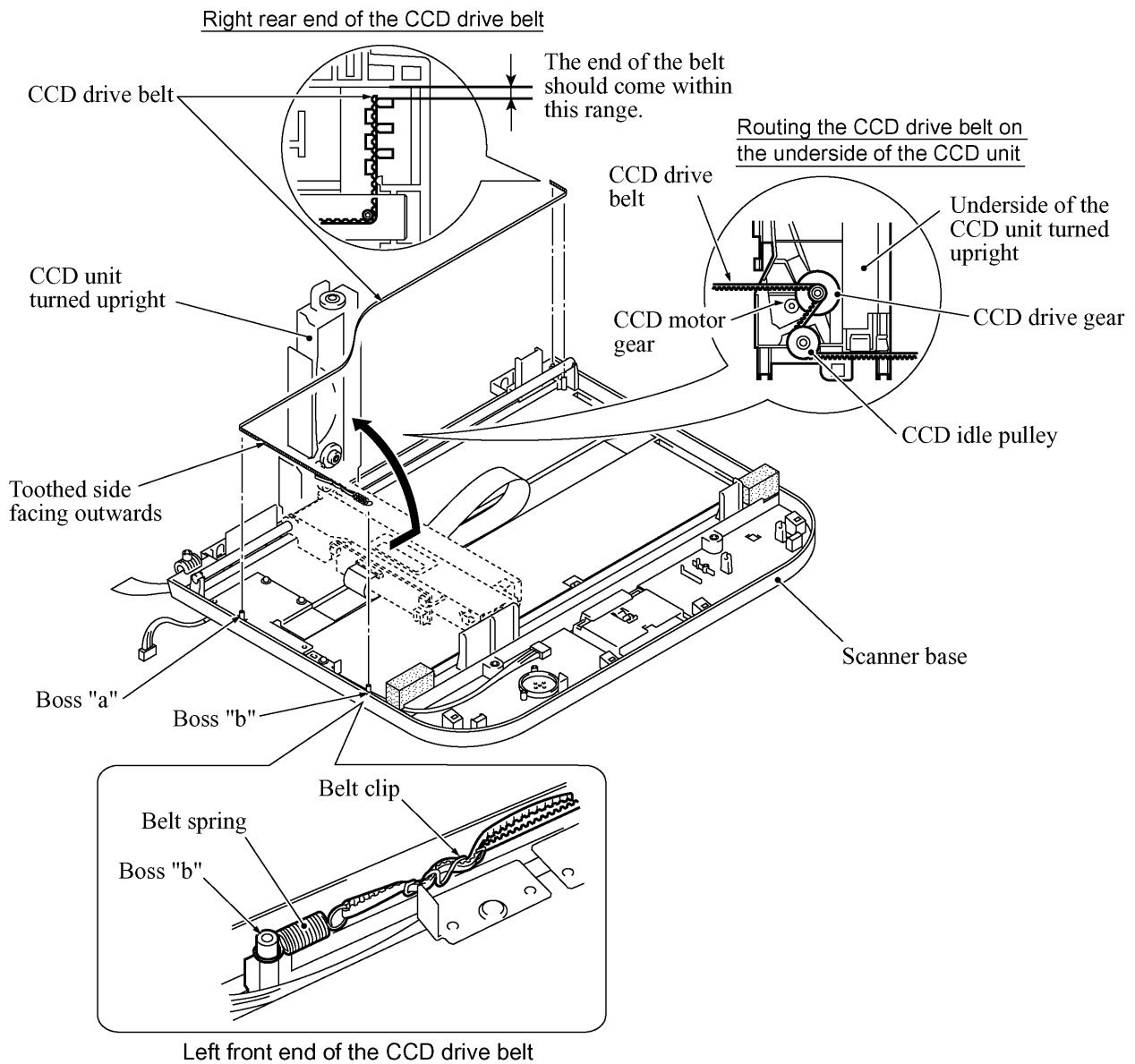

- (6) Disconnect the CCD flat cable from the CCD PCB, then release the cable that is attached to the underside of the CCD unit with double-sided adhesive tape.

NOTE: Only when the CCD unit or CCD flat cable is defective and requires replacement, release the flat cable. Once released, the flat cable should be attached using new double-sided adhesive tape.

- (7) Lift up the CCD rail together with the CCD unit from the scanner base, then pull out the CCD rail.

NOTE: When handling the CCD unit, do not touch the CCD PCB or glasses but hold the hatched sections as shown on the next page.

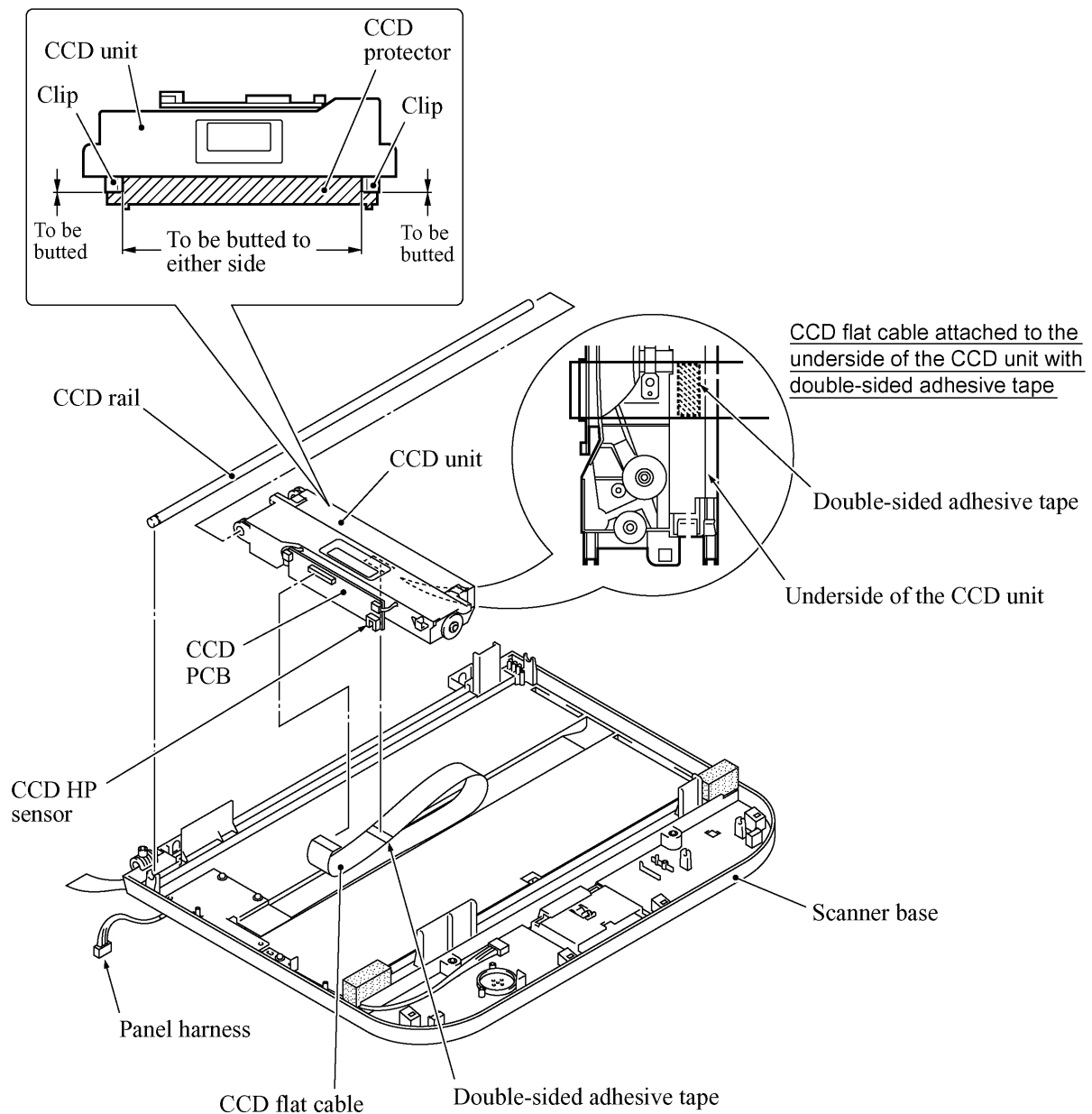

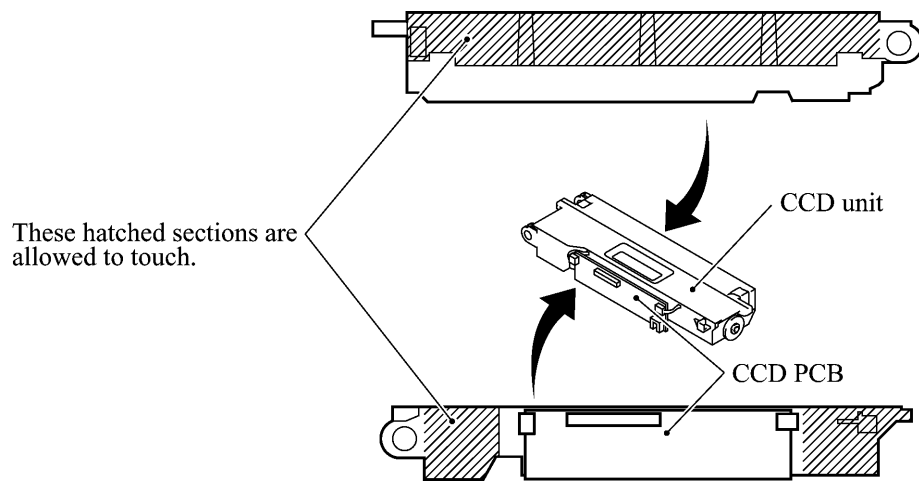

- (8) Remove the three screws and lift up the guide plate.
- (9) Remove the screw from the CCD HP sensor plate.

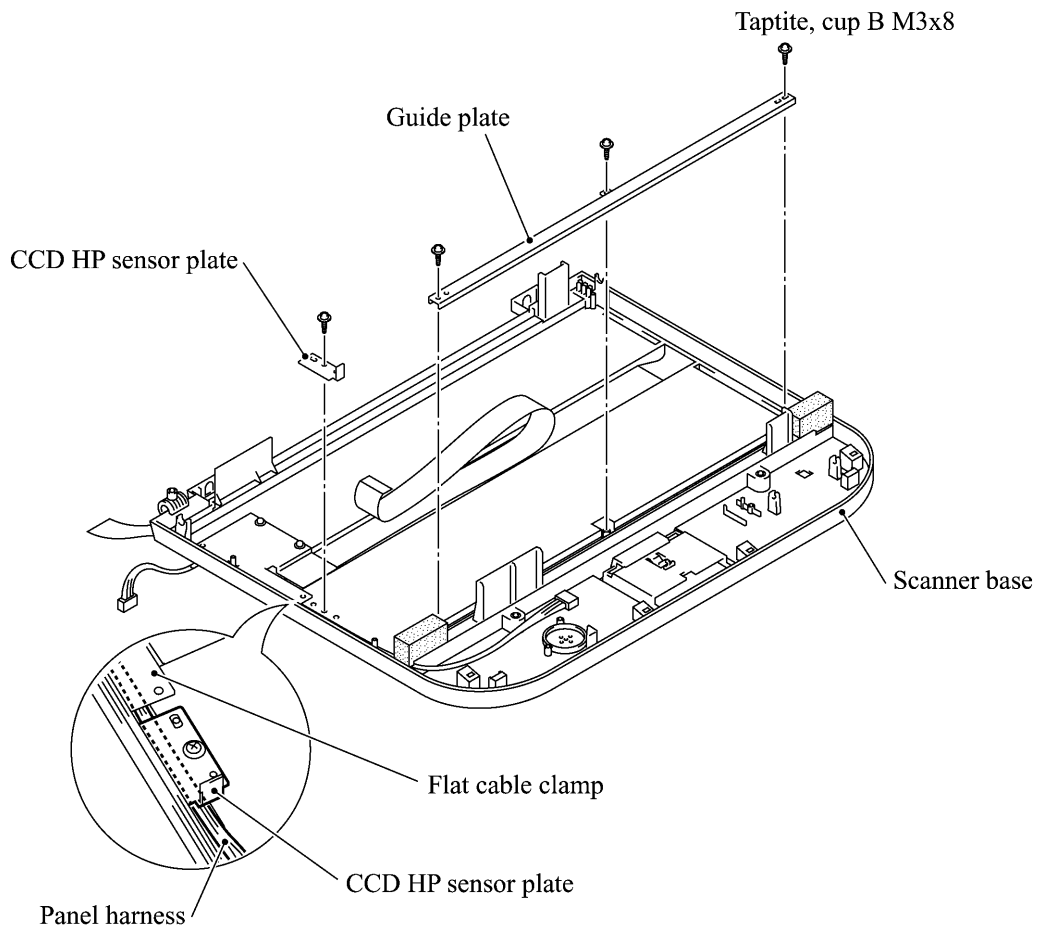

(10) Remove the two screws and take off the flat cable clamp.

(11) To take out the panel harness, remove sponges F and R that are backed with adhesive tape.

NOTE: Once removed, those sponges will become unusable and new parts will have to be put back in.

(12) To take out the CCD flat cable, remove sponge R.

CCD flat cable and panel harness secured to the scanner base

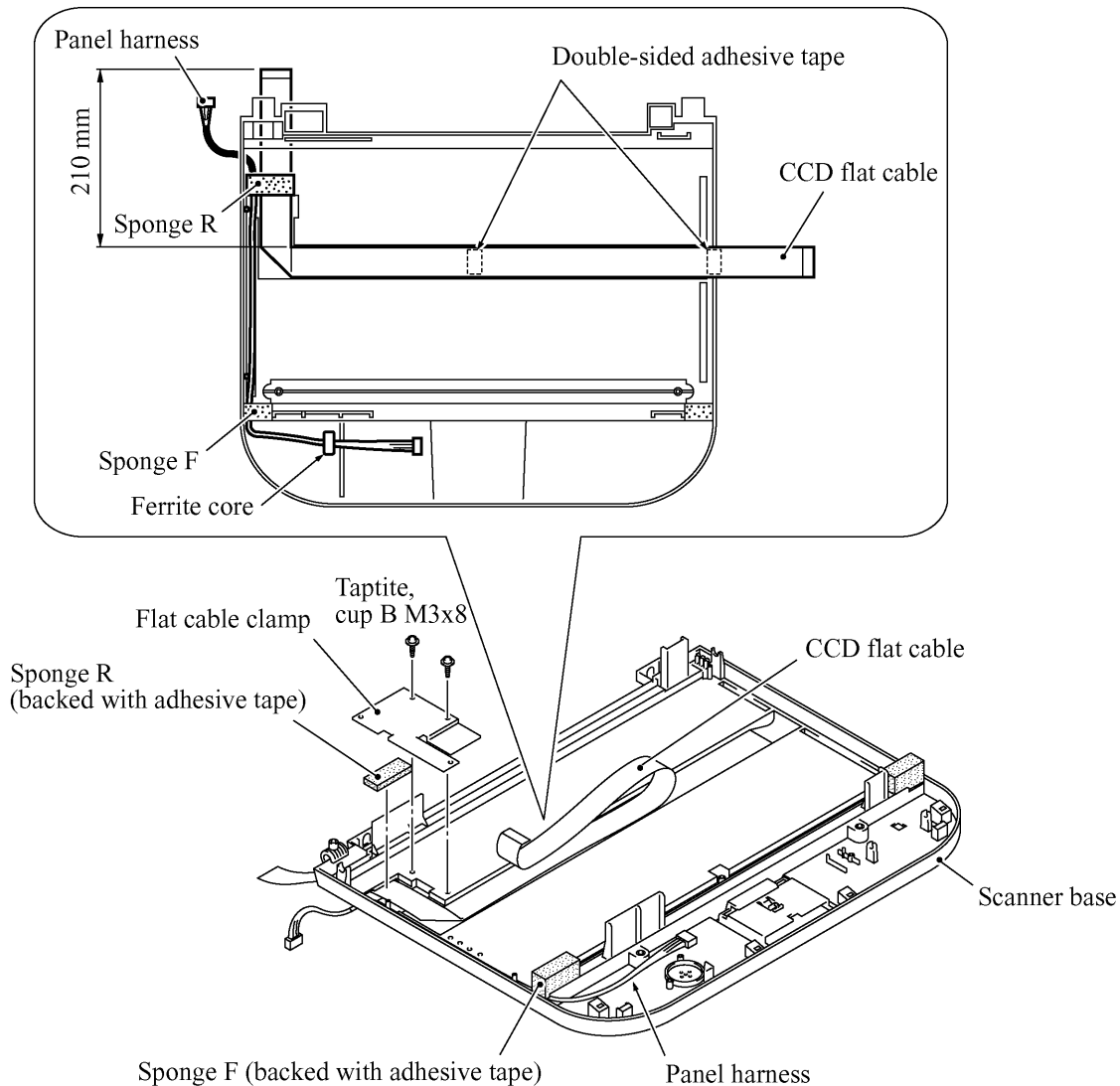

■ Reassembling Notes

- When replacing the CCD unit with a new one, you need to attach a CCD protector to it as specified on page 4-28. A new CCD protector is covered with a protection sheet, so remove the protection sheet before attaching.
- When using a new CCD flat cable, fold it and secure it to the scanner base with double-sided adhesive tape and sponge R (backed with adhesive tape) as illustrated above. Then attach it to the underside of the CCD unit with double-sided adhesive tape.
- When reassembling the components inside the scanner unit, use screws (Taptite, cup B M3x8). Never use longer ones (e.g., M3x10). Using longer ones will bore a hole in the scanner base.
- When installing the CCD drive belt to the scanner base, set its rear end within the range specified on page 4-27.

4.1.8 Front Cover

- (1) Press the rear ends of the front cover inwards (in the direction of arrow ①) to release bosses "a" from the front cover guides.
- (2) Remove the screw from each of the front cover guides.
- (3) While pulling the tab of each front cover guide up and to the front (in the direction of arrow ②) to release the guide from boss "b," remove the guide in the direction of arrow ③.

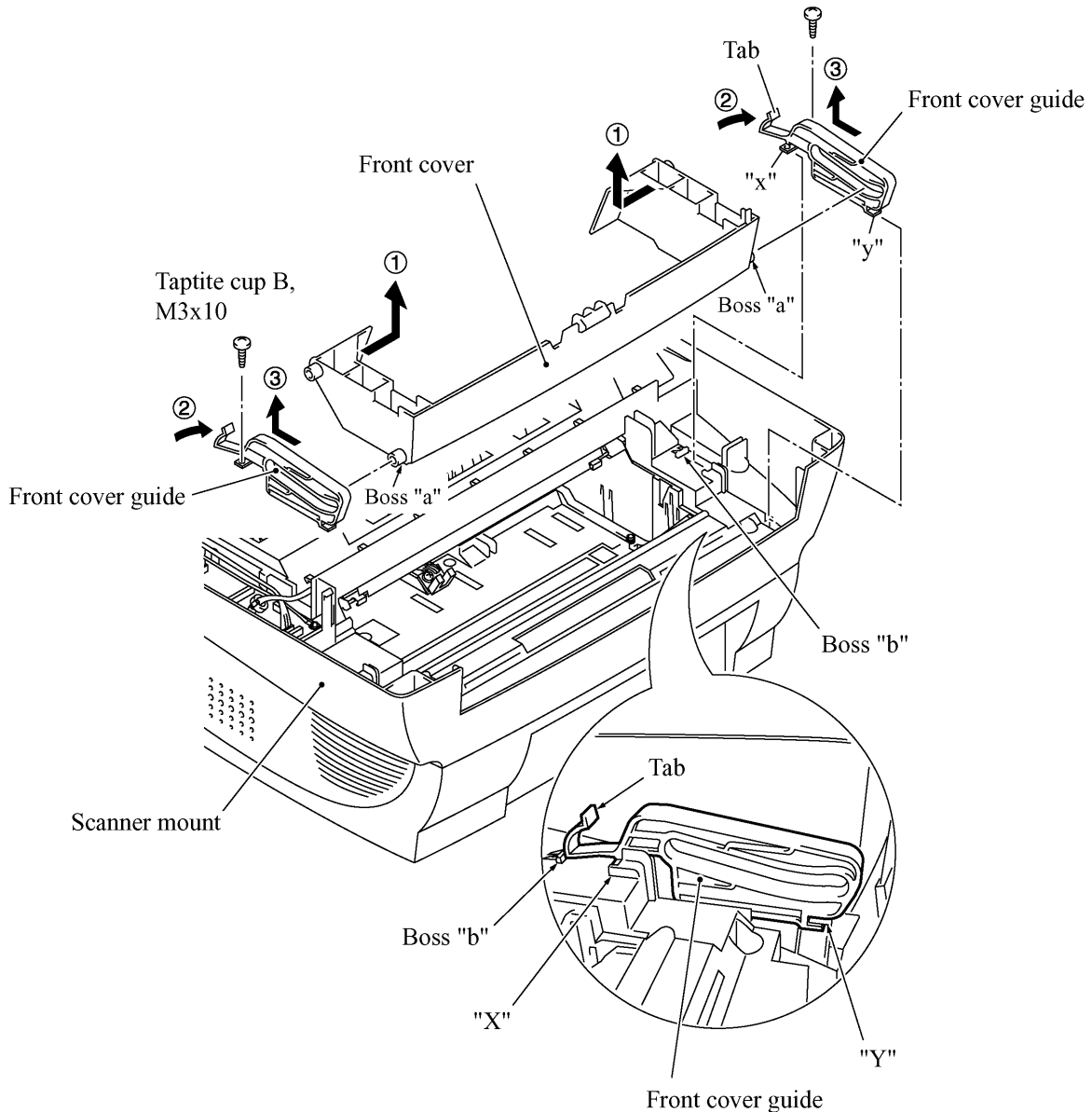

■ Reassembling Notes

- When setting the front cover guides back into place, fit sections "y" and "x" into "Y" and "X" of the scanner mount, respectively, while pushing the guides down and to the front.

4.1.9 Relay PCB

- (1) Disconnect the three relay harnesses from the relay PCB.
- (2) Remove the two screws. The cable clip will come off and the grounding wire will be released.
- (3) Lift up the relay PCB.

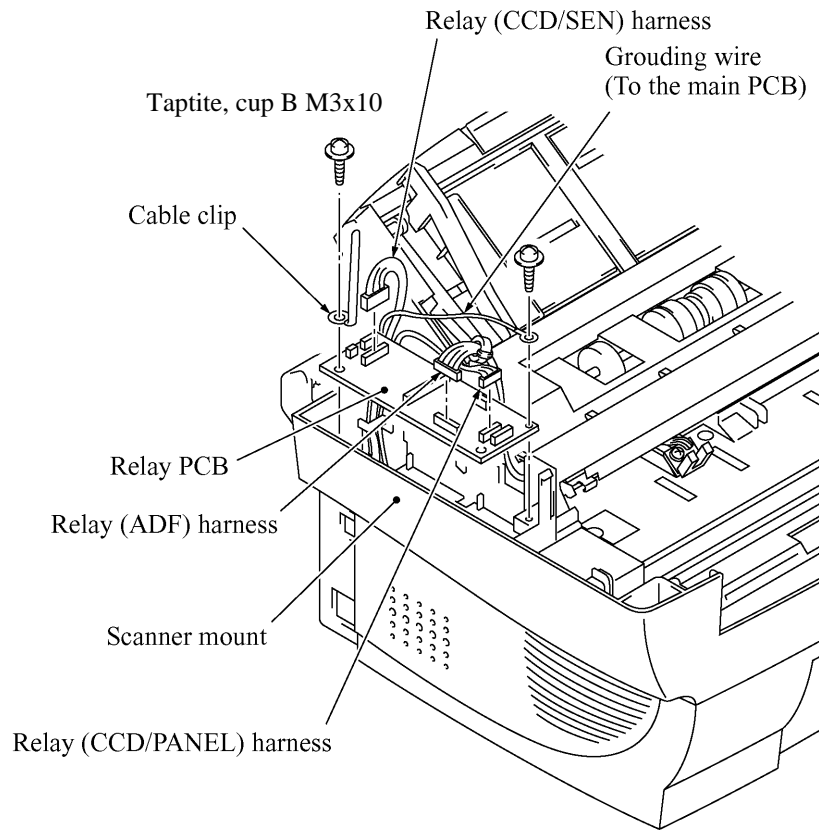

4.1.10 Scanner Mount

- (1) Remove the harness cover.

NOTE: Once removed, the harness cover will become unusable and a new part will have to be put back in.

- (2) Remove the relay (ADF) harness from seven latches and then bring it to the right.

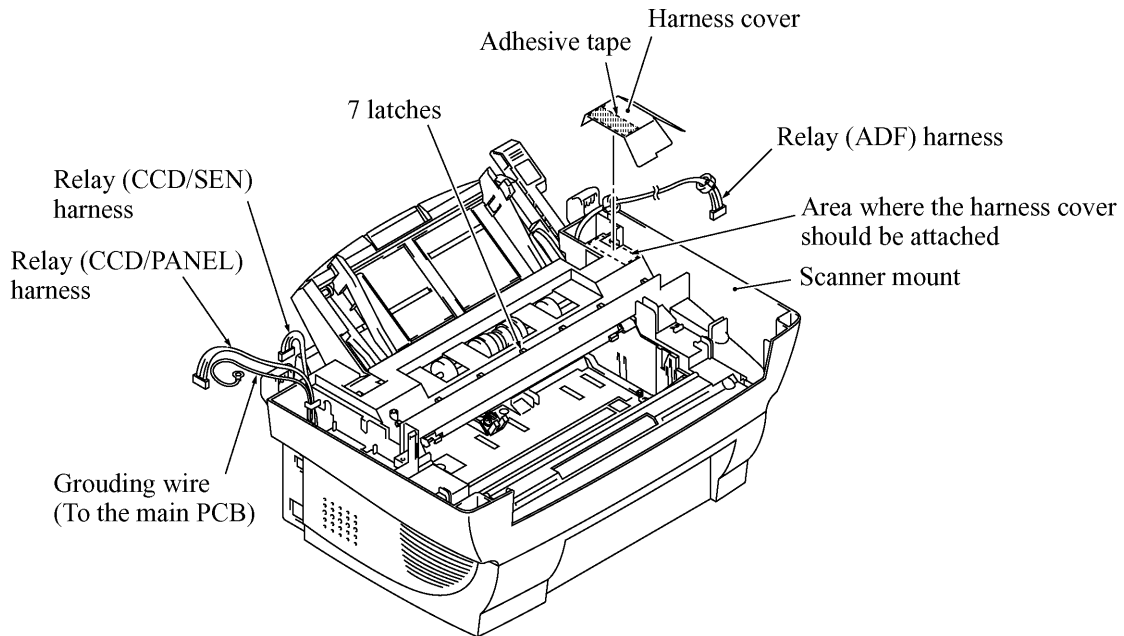

- (3) Remove the two screws from the scanner mount

- (4) Remove the scanner mount in the direction of the arrows.

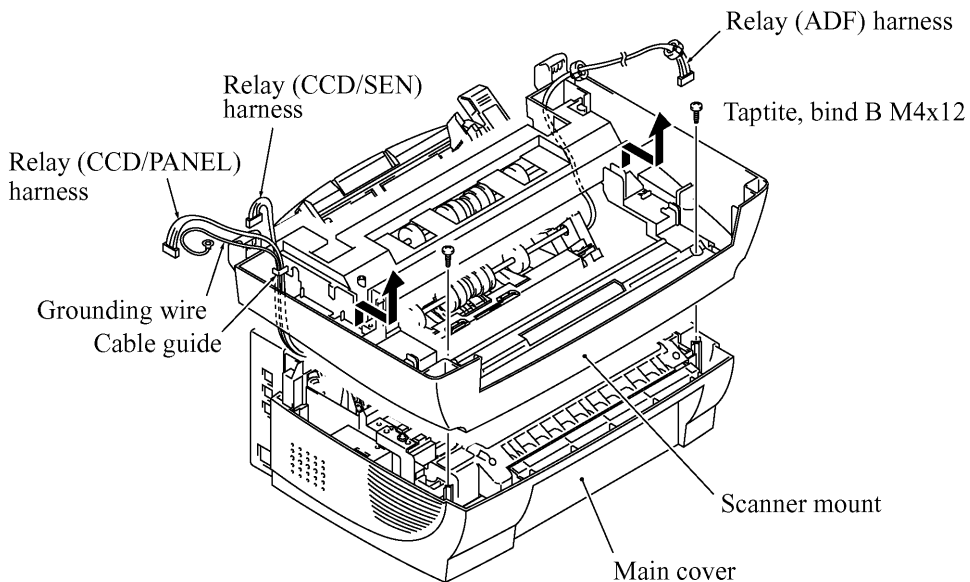

■ Reassembling Notes

- Route the relay (ADF) harness through seven latches on the scanner mount. Refer to Subsection 4.1.25, "Harness routing C."

4.1.11 Board Access Cover and Auto Sheet Feeder (ASF)

- (1) Remove the two screws from the board access cover. (Those screws secure also the ASF to the main cover.)
- (2) Push down the top of the board access cover to release the two latches from the main cover, then pull it to the rear.
- (3) Pull the ASF to the front and then lift it up.

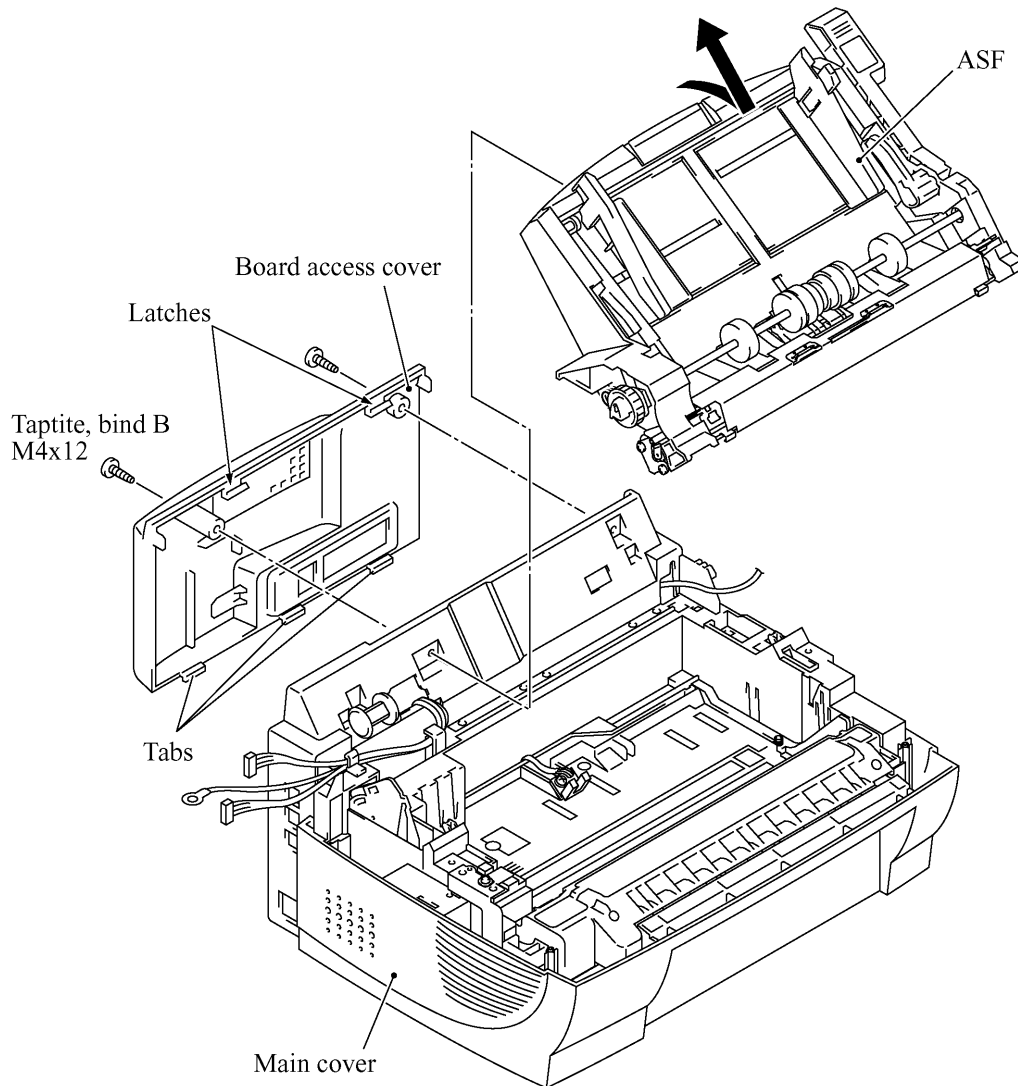

[Disassembling the ASF]

- 1) Unhook the release lever spring.
- 2) Remove screw "a" and pull out the release lever.
- 3) Turn the release cam to the front and pull it out to the left.

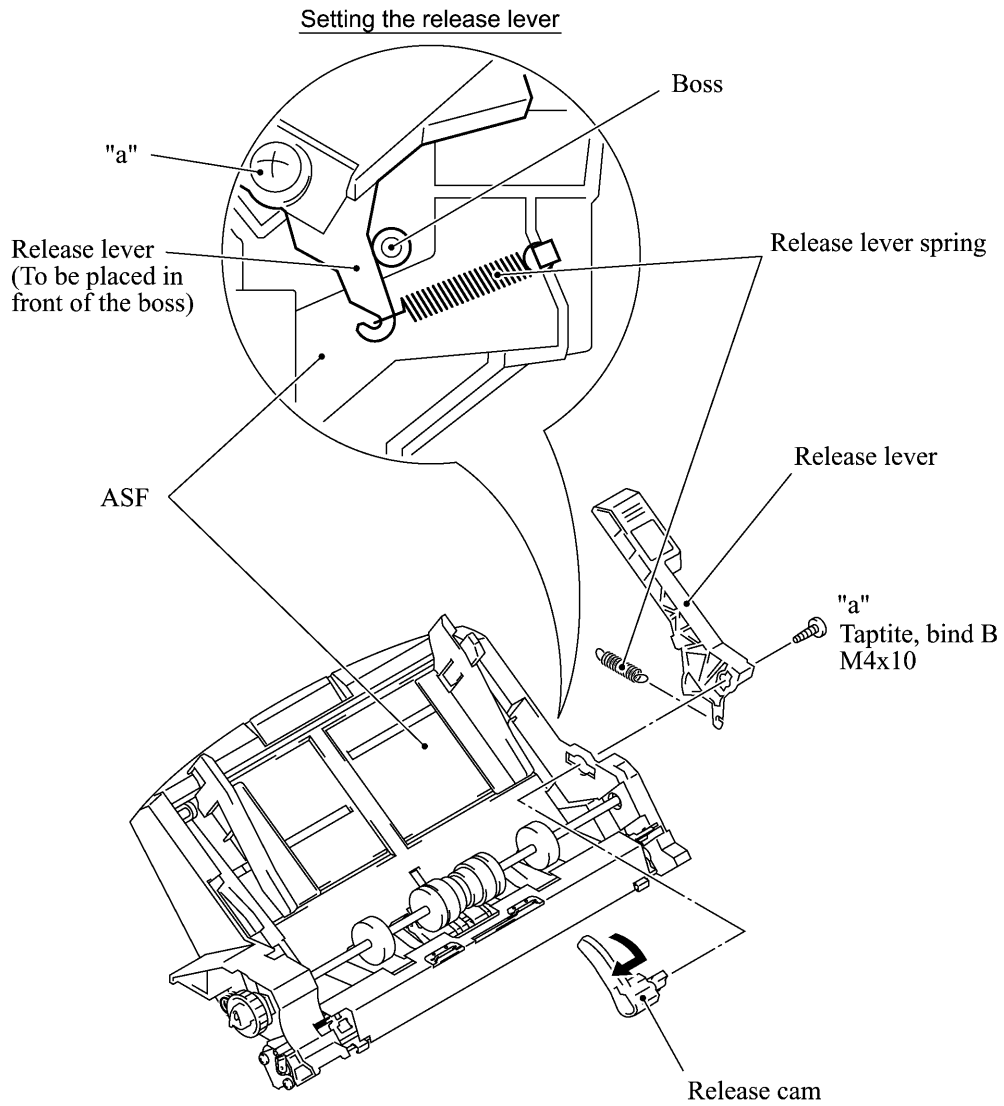

- 4) At the right end of the ASF, remove the screw from the grounding leaf spring R. (It is not necessary to remove the leaf spring.) Next pull out the pawled bushing R.

At the left end of the ASF, remove the sector gear and its spring. Unlatch the pawled bushing L to the left and then remove it from the paper pull-in roller shaft. Remove the paper pull-in roller.

Hooking the sector gear spring

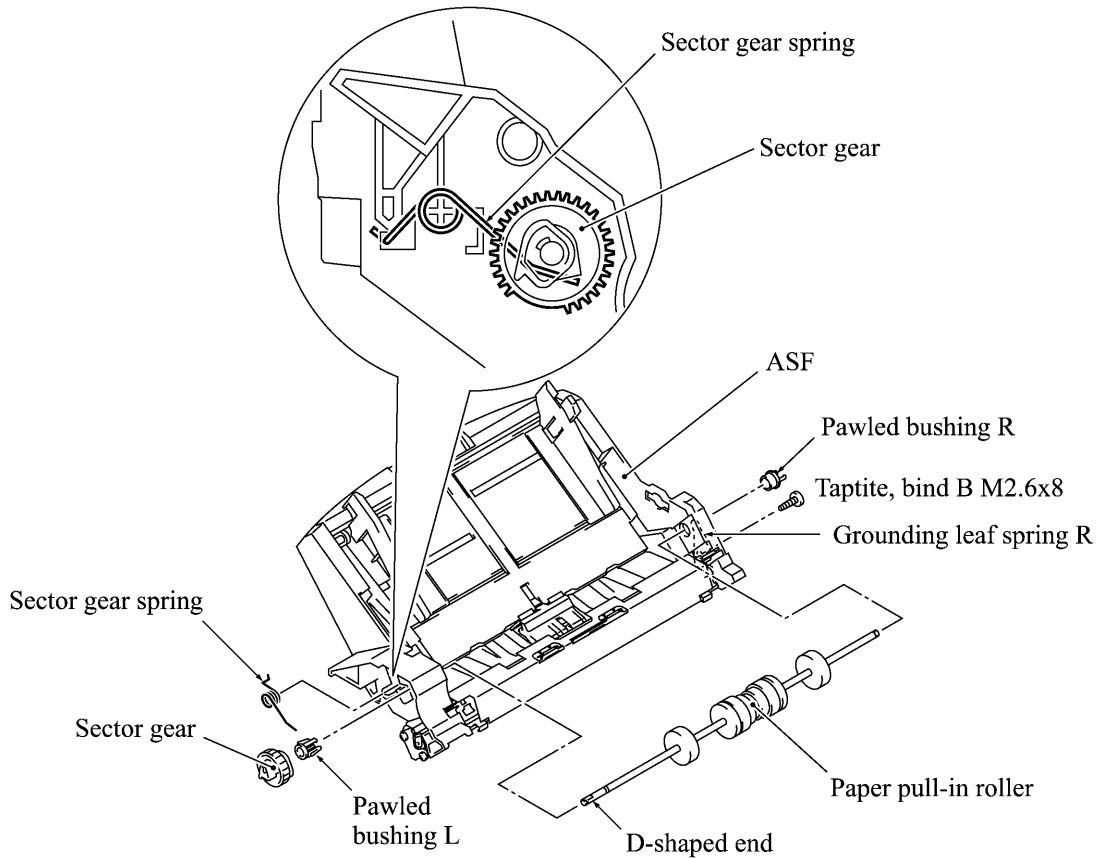

- 5) Push the right and left ends of the separation pad ASSY inwards and take it out. The spring also comes off.

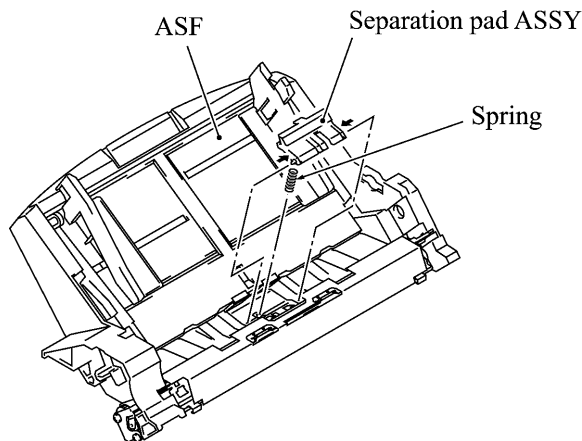

6) Turn the ASF upside down, then remove the registration sensor actuator.

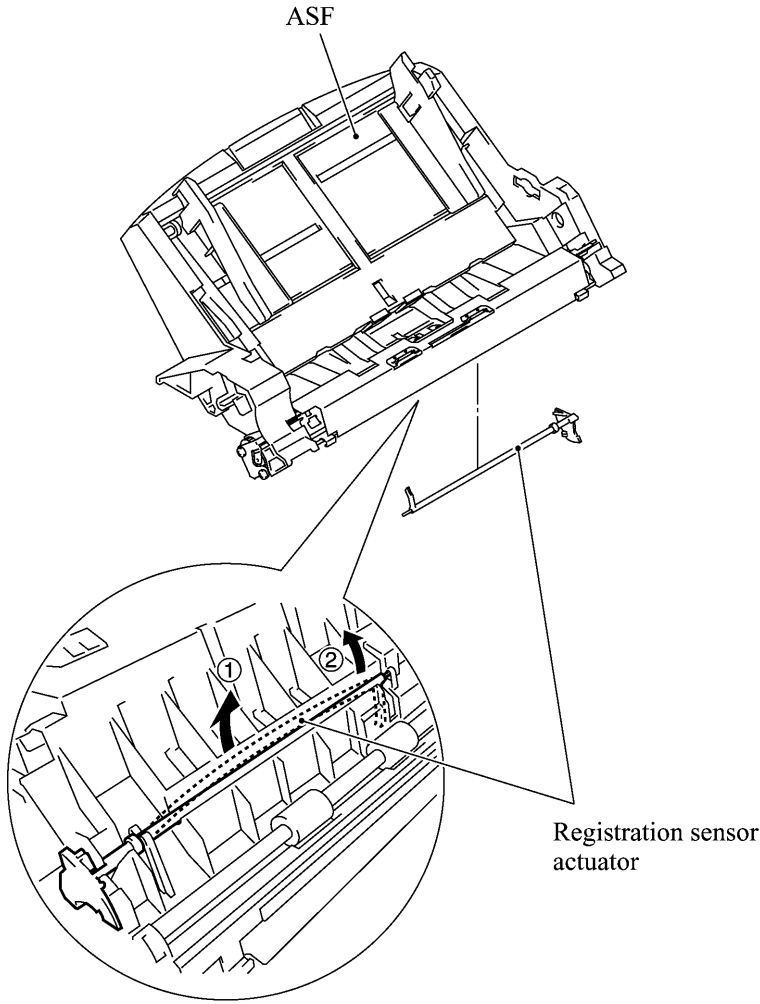

Viewed from the bottom

7) There are two sets of pinch roller units. At each set, remove the leaf spring (in the order of ① to ③ shown below), pinch rollers, and pinch roller shaft.

8) At the right end of the paper feed roller, remove the screw and take off the grounding leaf spring R if you have not removed it in step 4) above.

Remove the pawled pushing R.

9) At the left end of the paper feed roller, remove two screws and take off the grounding leaf spring L, pawled PF gear, and idle gear.

Then remove the paper feed roller.

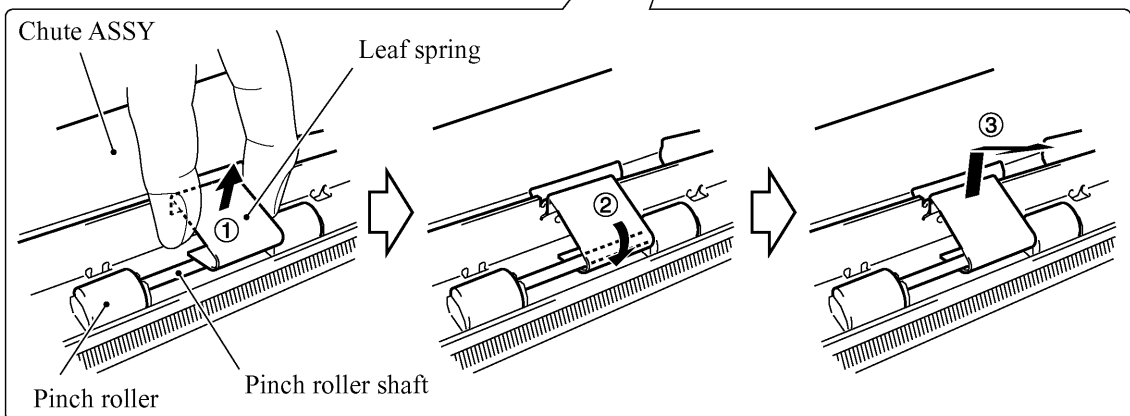
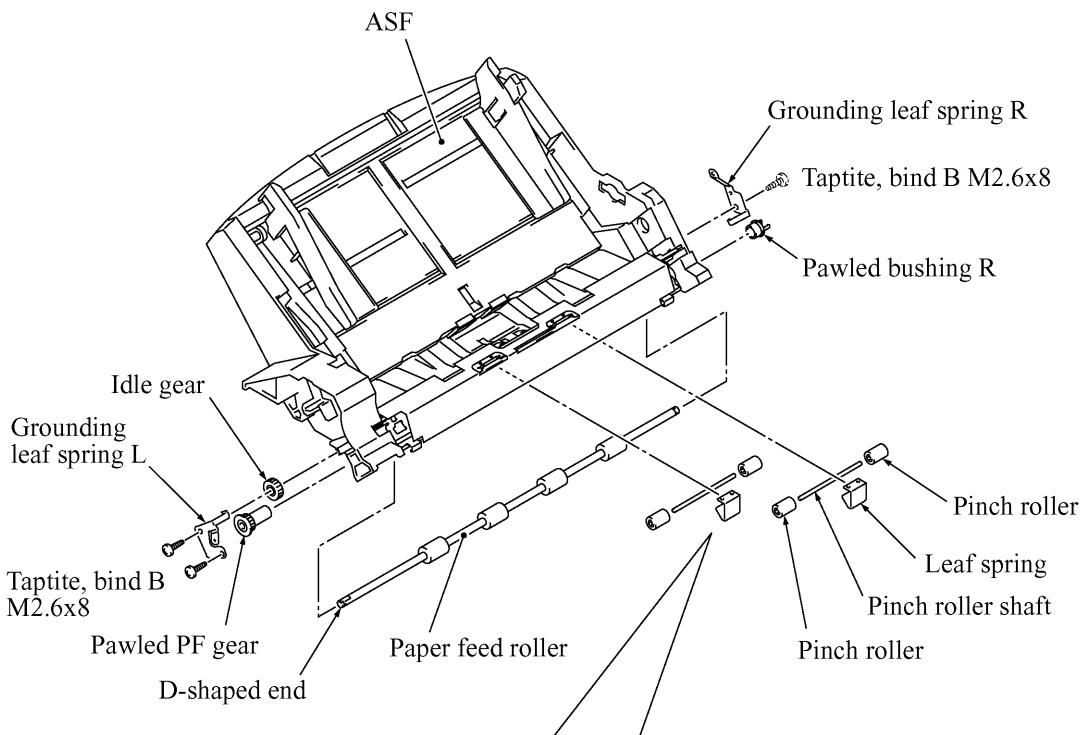

Removing the leaf spring from the pinch roller shaft

10) Press the lock arm provided at the left inside of the ASF to the rear with a screwdriver, slide the ASF chute ASSY to the left, and take it out to the front.

NOTE: To replace only the black film attached to the chute, do not remove the chute ASSY from the ASF.

NOTE: A new chute and black film will be provided separately. When replacing the ASF chute ASSY, first set the chute into the ASF and then attach the black film to the chute. If you first attach the black film to the chute and then set the ASF chute ASSY, then the black film may be bent or wrinkled.

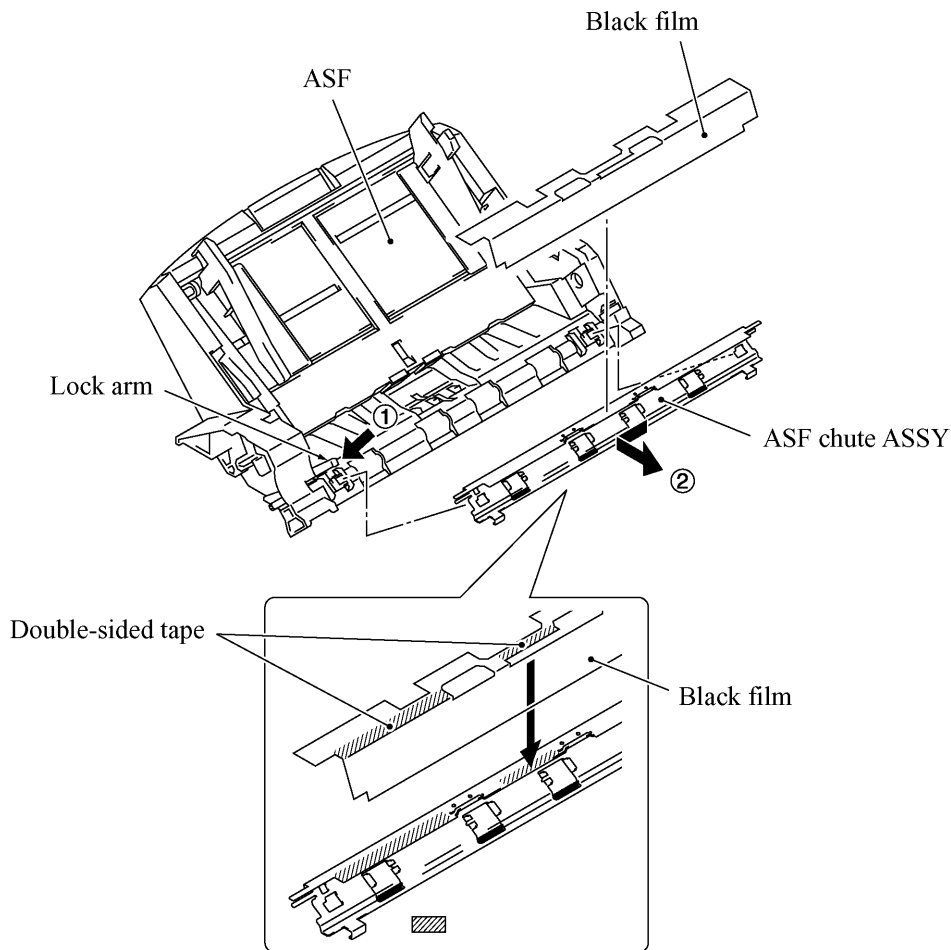

■ Reassembling Notes

- Set the paper feed roller into the ASF with the D-shaped end facing leftwards.
- Set the paper pull-in roller into the ASF with the D-shaped end facing leftwards.
- When setting the release lever back into place, turn the release cam to the rear and then set the release lever so that the bottom end of the release lever comes in the front of the boss provided on the ASF, as illustrated on page 4-35.

4.1.12 Heat-fixing Unit, FU Lamp, and Paper Ejection Sensor Actuator

- (1) Remove the two screws from the heat-fixing unit.
- (2) Lift up the heat-fixing unit and disconnect the blue and brown heater wires (of the heater harness) from the heat-fixing unit. Then disconnect the heater thermistor harness from the EL (eraser lamp) board.
- (3) Remove the paper ejection sensor actuator from the bottom of the heat-fixing unit.

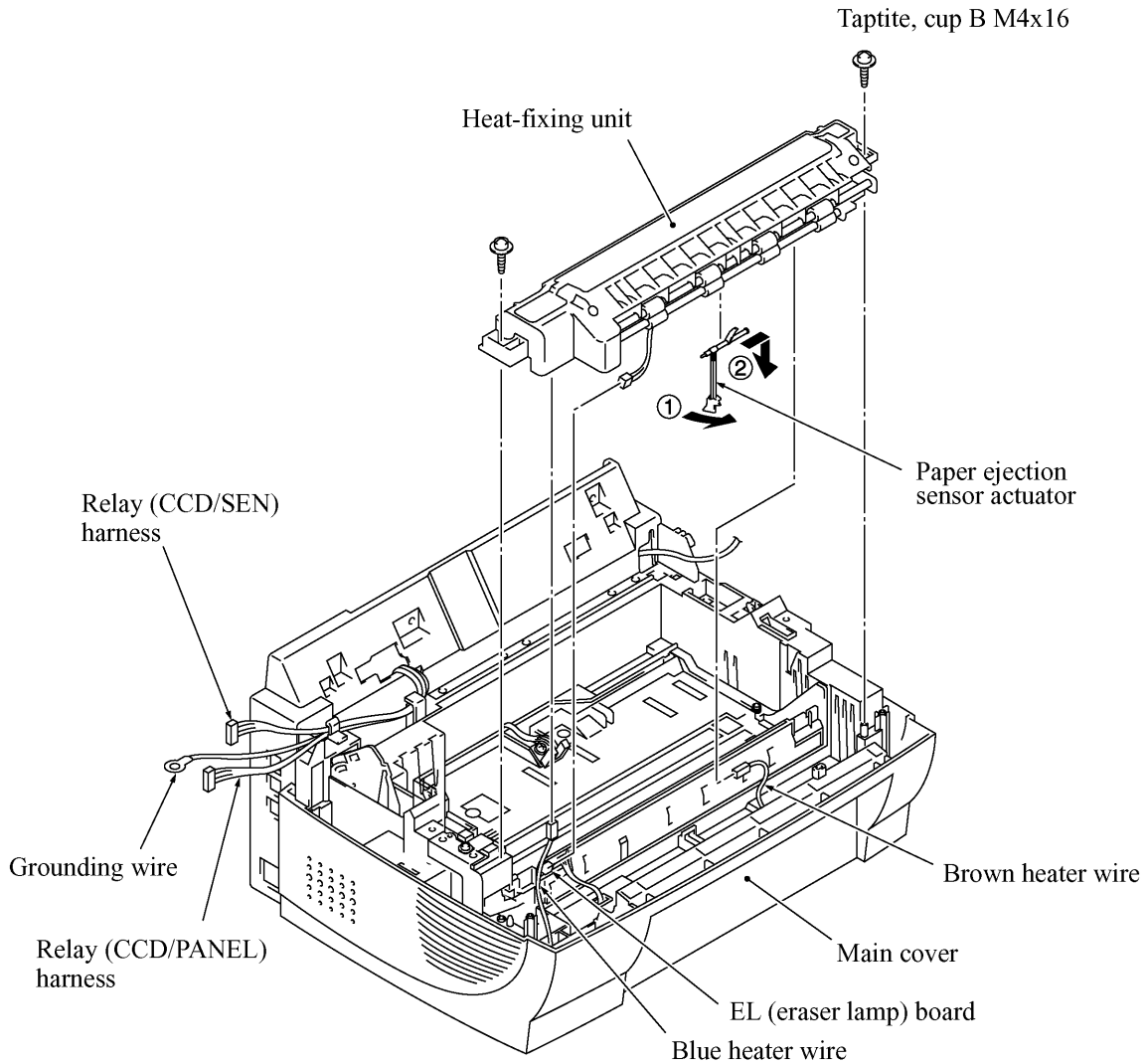

- (4) To take out the FU lamp from the heat-fixing unit, remove two screws "a."
- (5) Fully open the upper cover and remove it.
- (6) Unlatch the idle gear 16 and remove it.
- (7) Loosen screw "b."
- (8) Remove screw "c" and take out the lock plate.
- (9) Slightly lift up the left end of the heater roller and hold the left end of the FU lamp. While pinching the fuse plate R with your right hand, pull out the FU lamp from the heater roller.

CAUTION: Do not touch the FU lamp. If you have touched it, clean it thoroughly with alcohol.

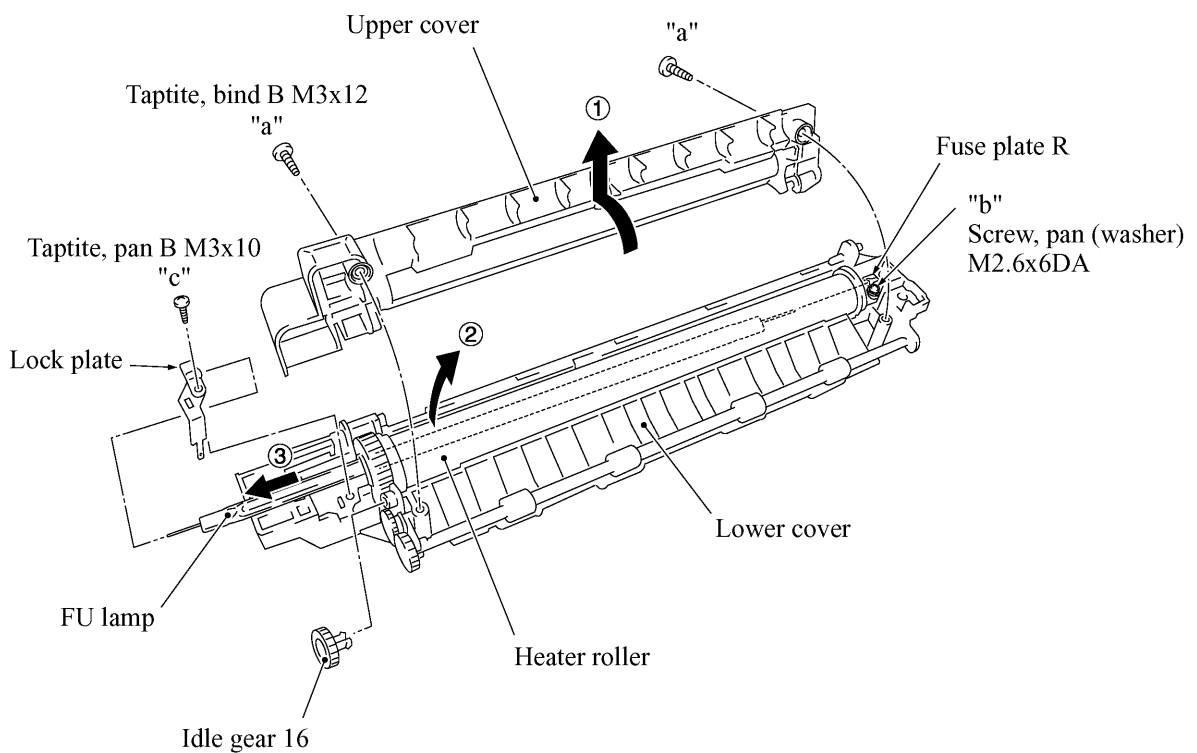

■ Reassembling Notes

- When setting the FU lamp into the heat-fixing unit, be sure to insert the right edge of the wire into the folded fuse plate R.
- A new heat-fixing unit will be provided with the heater thermistor harness being taped to the unit. When installing the unit, remove the tape.
- Route the blue and brown heater wires on the main cover as illustrated in Subsection 4.1.25, "Harness routing F."

4.1.13 Laser Unit and Toner Sensor PCB

- (1) Disconnect the polygon motor flat cable, toner sensor harness, and laser diode harness from the main PCB.
- (2) Remove the three screws from the laser unit.
- (3) Lift up the laser unit.

NOTE: When handling the laser unit, take care not to touch the inside of the unit, glass, or mirror.

NOTE: On the small PCB at the right side of the laser unit is a 2-pin connector which is for the adjustment in the factory. Do not disturb it.

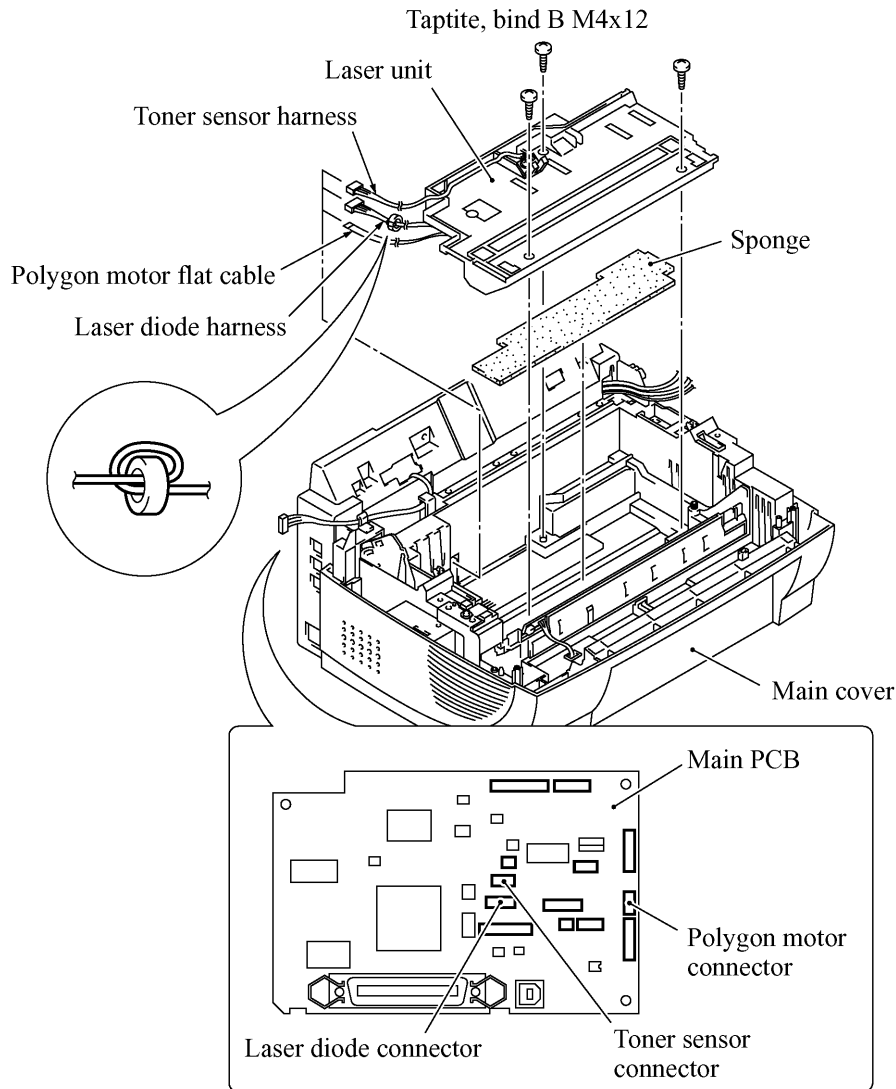

■ Reassembling Notes

- When replacing the laser unit with a new one, be sure to attach a ferrite core to the laser diode harness of the new laser unit. Wind the harness around the ferrite core by two turns as shown above, just like the laser diode harness of the old laser unit.
- On the underside of the laser unit, route the laser diode harness, polygon motor flat cable, and toner sensor harness as illustrated in Subsection 4.1.25, "Harness routing G."
- Before putting the laser unit back into place, check for any toner particles, paper dust or dirt, and clean them out.
- Make sure that the sponge is placed below the laser unit.

4.1.14 Main PCB

- (1) Disconnect the following harnesses and flat cable from the main PCB:
 - NCU harness
 - Low-voltage power harness
 - Main motor harness
 - Relay (ADF) harness
 - Relay (CCD/PANEL) harness
 - High-voltage power flat cable
 - Main-fan harness
 - Solenoid harness
 - Relay (CCD/SEN) harness
 - Speaker harness
- (2) Remove two screws "a" from the main shield.
- (3) Remove two screws "b" from the parallel interface connector.
- (4) Remove two screws "c" from the main PCB and then take it off from the PCB support. The grounding wire will be released.

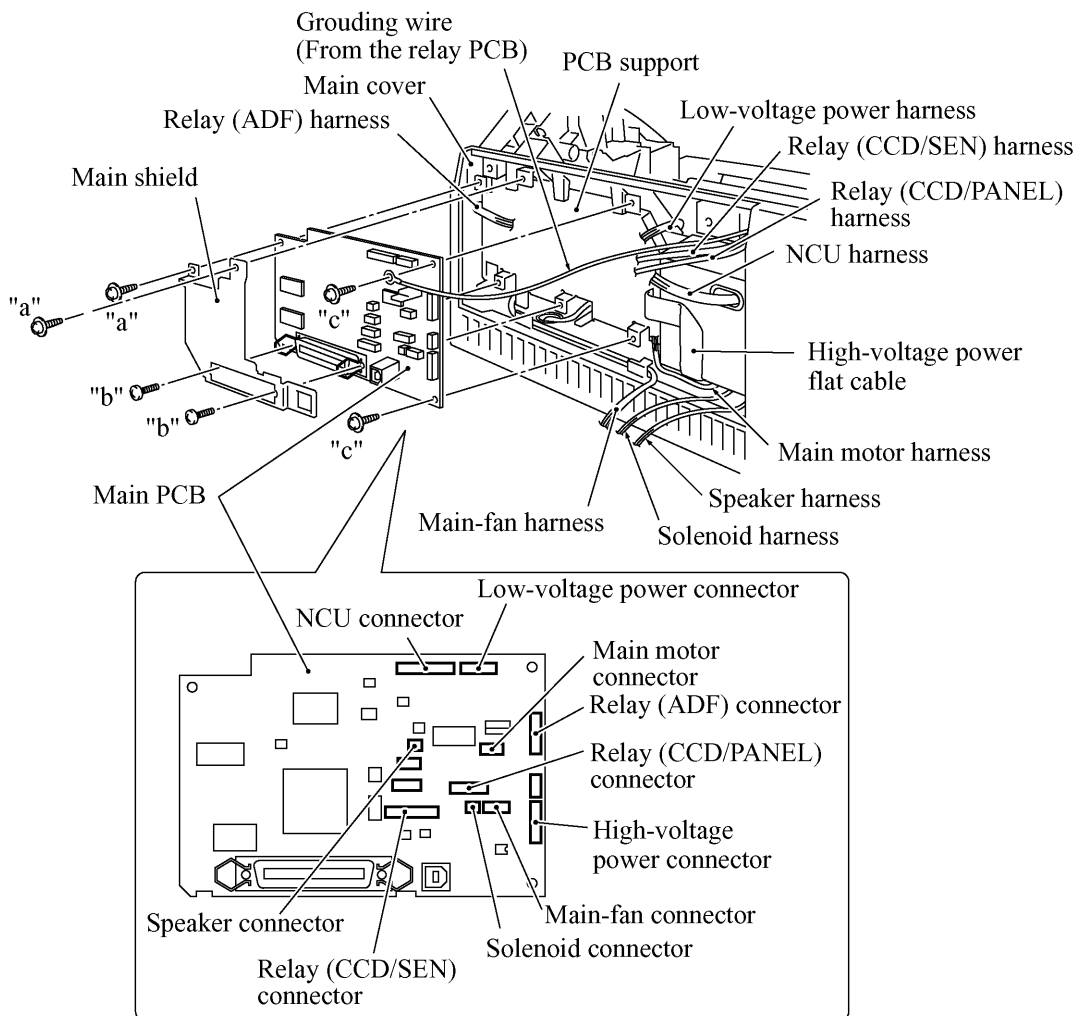

"a" and "c": Taptite, cup S M3x6
 "b": Taptite, pan S M3x12

■ Reassembling Notes

- Be sure to route the harnesses and flat cable as illustrated in Subsection 4.1.25, "Harness routing D."

Make sure that the main motor harness is routed closest to the main PCB and that the relay (CCD/SEN) harness is routed after other harnesses are connected.

Make sure that harnesses having ferrite cores are taped. In particular, the main motor harness should be taped above and below the ferrite core.

- If you replace the main PCB, be sure to follow the flowchart given on the next page.

Setting up the main PCB after replacement

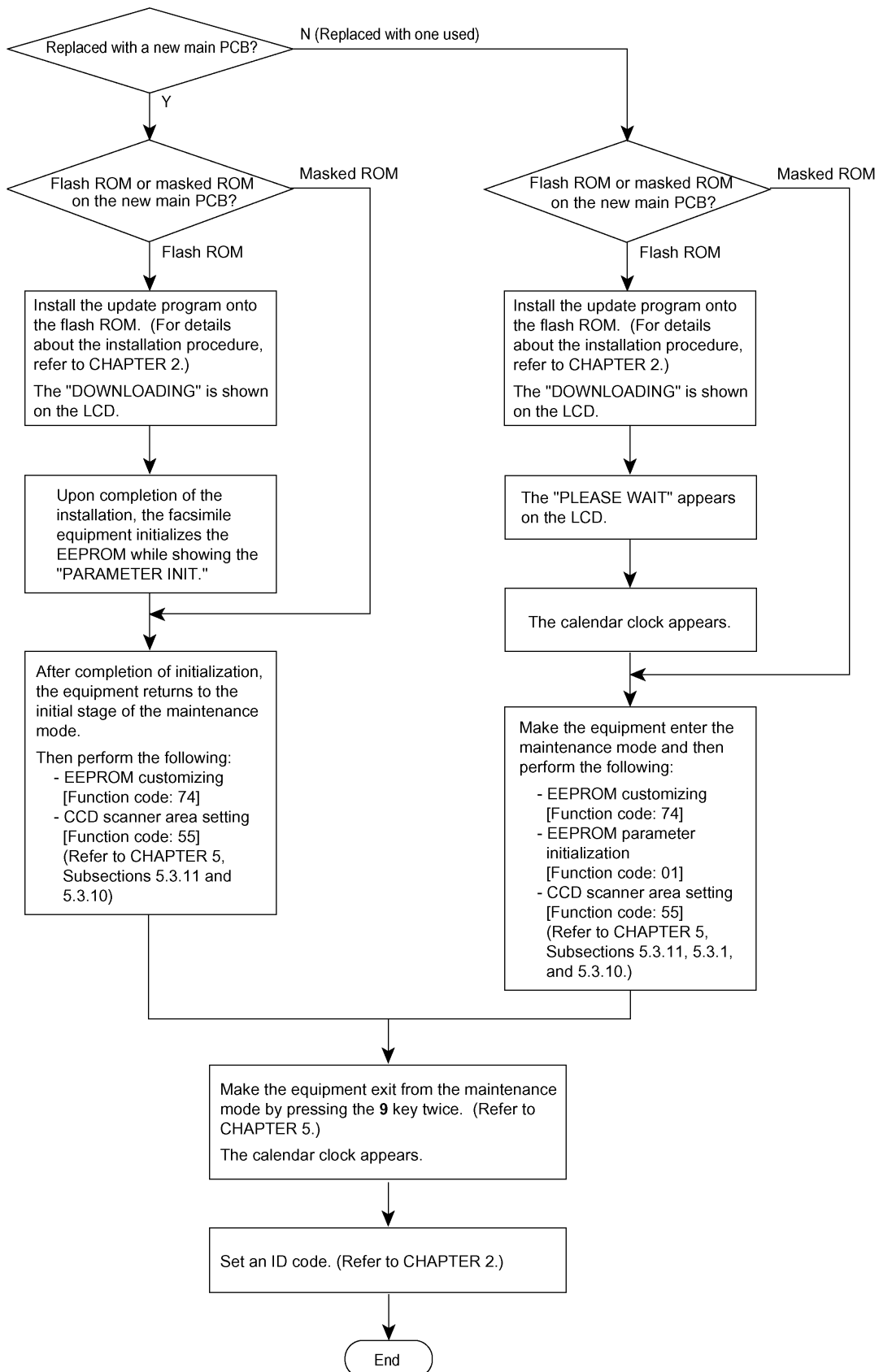

4.1.15 Bottom Plate

- (1) Turn the machine upside down.
- (2) Remove the nine screws (four "x" and five "y") from the bottom plate, then lift it up.

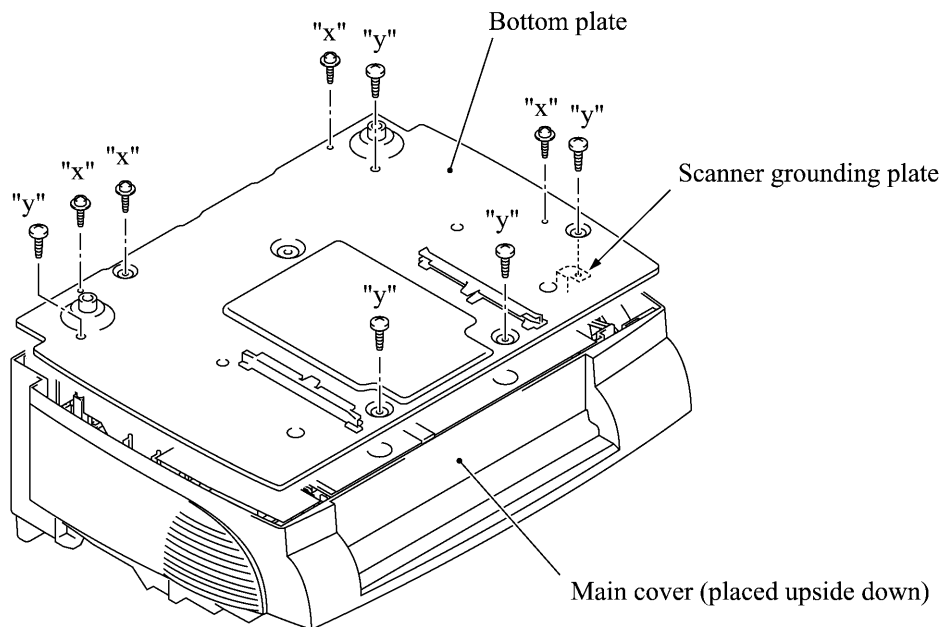

"x": Taptite, cup S M3x6

"y": Taptite, bind B M4x12

4.1.16 Low-voltage Power Supply PCB

- (1) Remove screw "a" and take off the low-voltage insulator sheet.
- (2) Remove screws "c" and "d" to release the grounding wire and power inlet support, respectively.
- (3) While pulling the right rear of the main cover (placed upside down) outwards to release the ON/OFF switch, lift up the power inlet support.

For the new type of the power inlet support having an opening: You need to cut off the binder that fastens the blue and brown lead wires of the AC power cord to the power inlet support.

- (4) Remove screw "b."
- (5) Slightly lift up the low-voltage power supply PCB and disconnect the low-voltage power harness and heater harness (of the blue and brown wires).

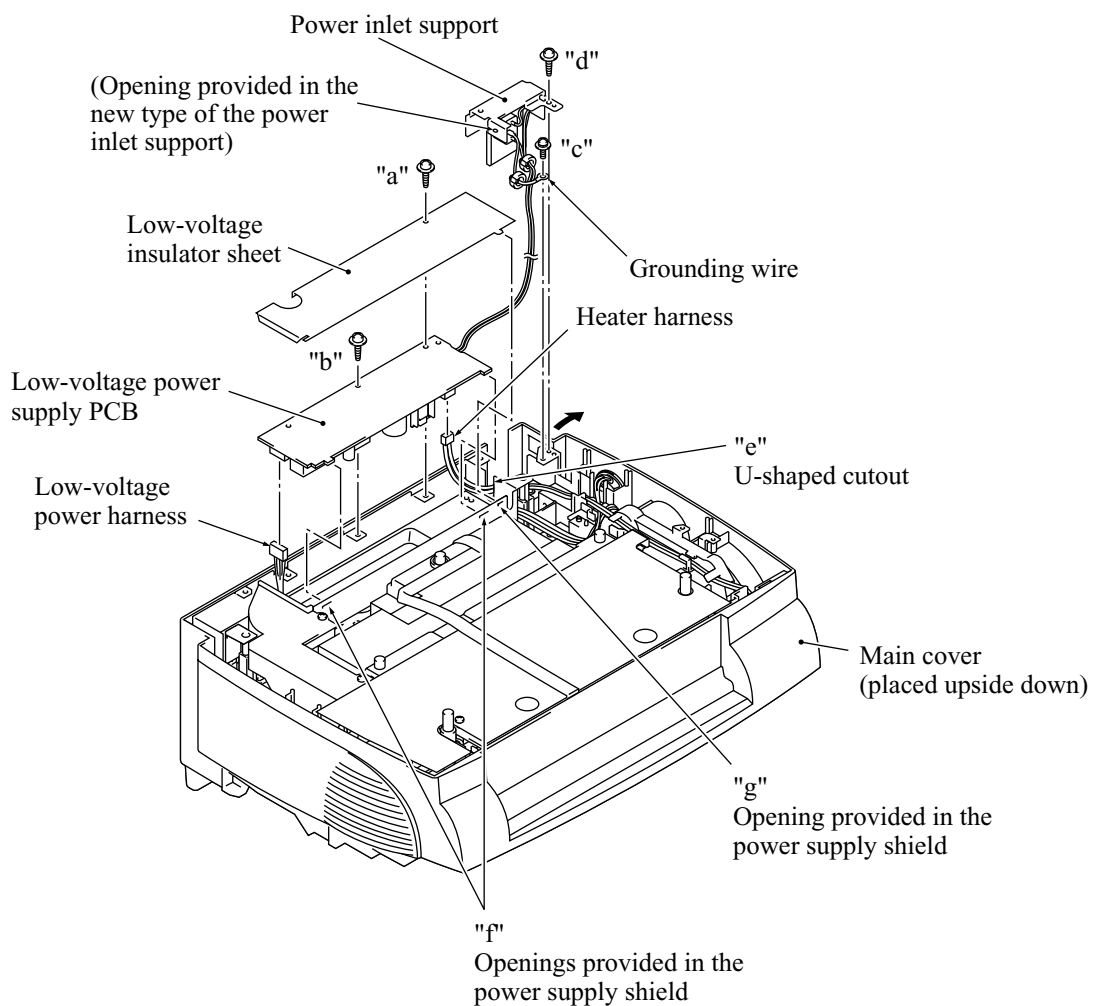

"a," "b," and "d": Taptite, cup S M3x6
"c": Screw, pan (washer) M4x8DB

■ Reassembling Notes

- Be sure to route the heater harness through U-shaped cutout "e" provided in the power supply shield. Then, route the AC power cable through the same cutout "e" on the heater harness. (Refer to Subsection 4.1.25, "Harness routing H.")
- Fit the front tabs of the low-voltage power supply PCB into openings "f."
- Fit the front tab of the insulator sheet into opening "g."
- To prevent the blue and brown lead wires of the AC power cord from getting damaged by the edge of the power inlet support or the end of screw "c," be sure to observe the following routing instructions:

For the power inlet support having no opening

- 1) Route the grounding wire between the boss and the power supply shield as shown below.
- 2) Push down the ferrite cores of the AC lead wires and grounding wire.
- 3) Secure the grounding terminal to the power inlet support with screw "c" at an angle shown below.

Push down these ferrite cores.

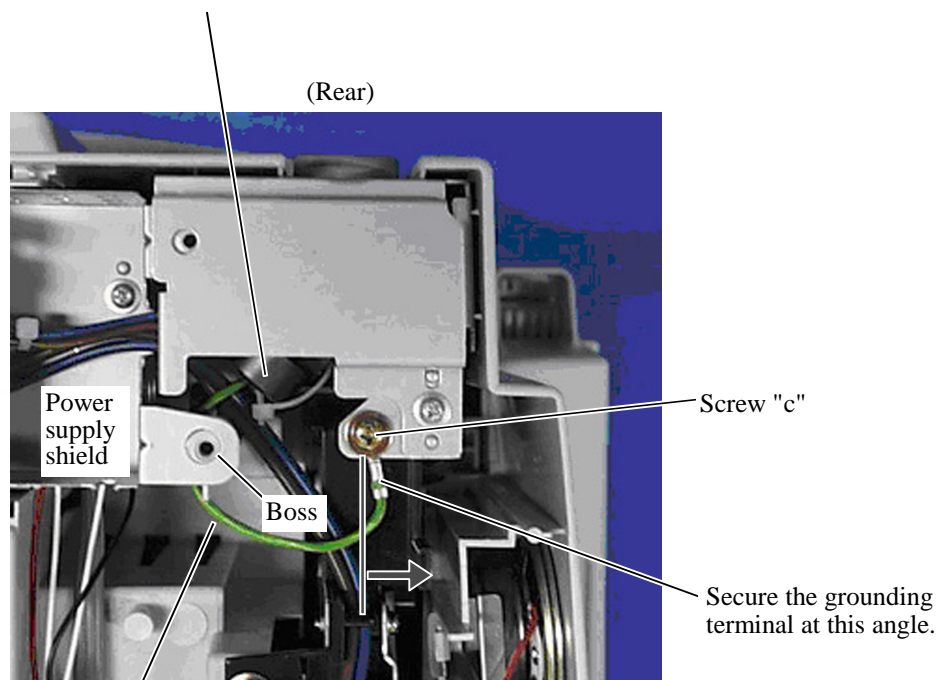

Route the grounding wire between the boss and the power supply shield.

For the new type of the power inlet support having an opening

- 1) Route the AC lead wires (blue and brown) through the opening provided in the power inlet support and pull them in the direction shown below to bring the ferrite cores closer to the opening.
- 2) Fasten the AC lead wires to the power inlet support with a binder.

For machines without power switch

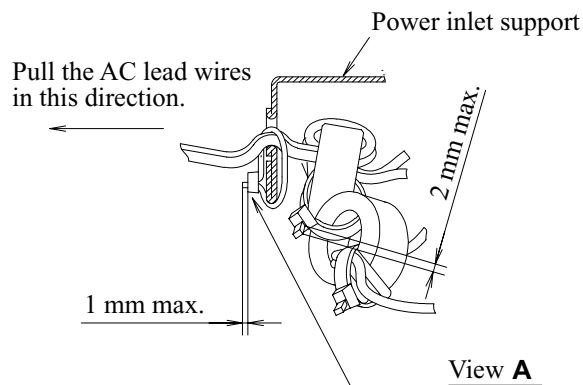
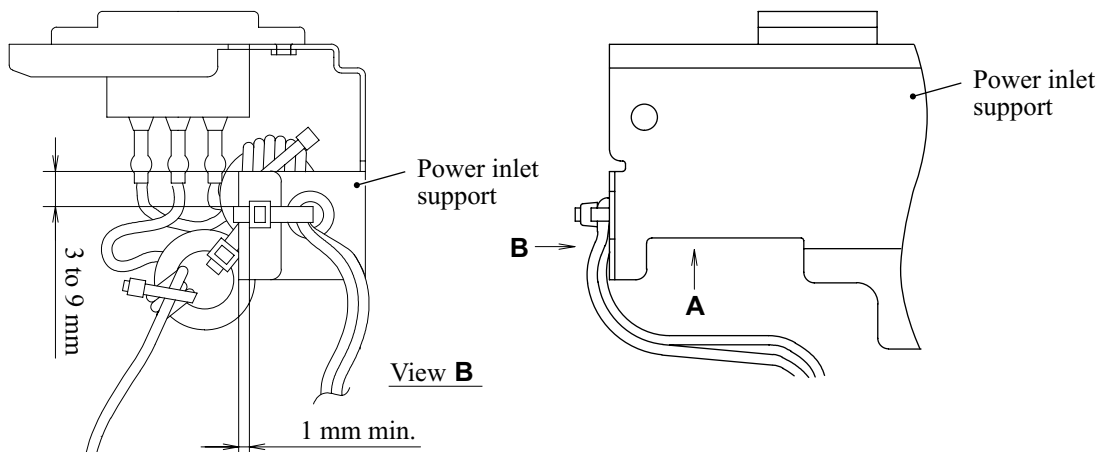

For machines with power switch

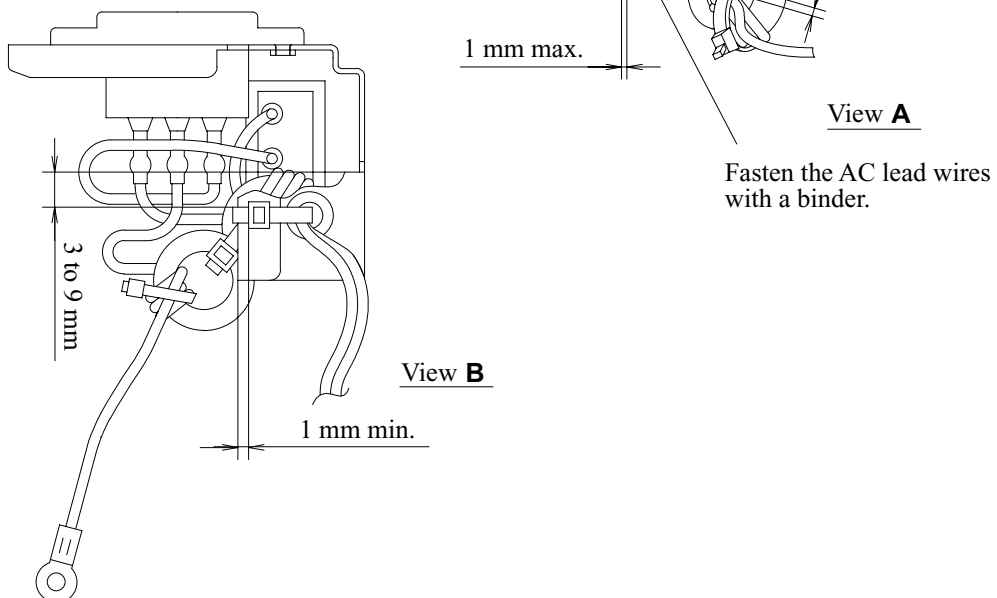

- 3) Secure the grounding wire to the power inlet support with screw "c."

4.1.17 High-voltage Power Supply PCB

- (1) Remove the screw and take off the high-voltage insulator sheet.
- (2) Slightly lift up the high-voltage power supply PCB and disconnect the high-voltage power flat cable and EL (eraser lamp) harness.

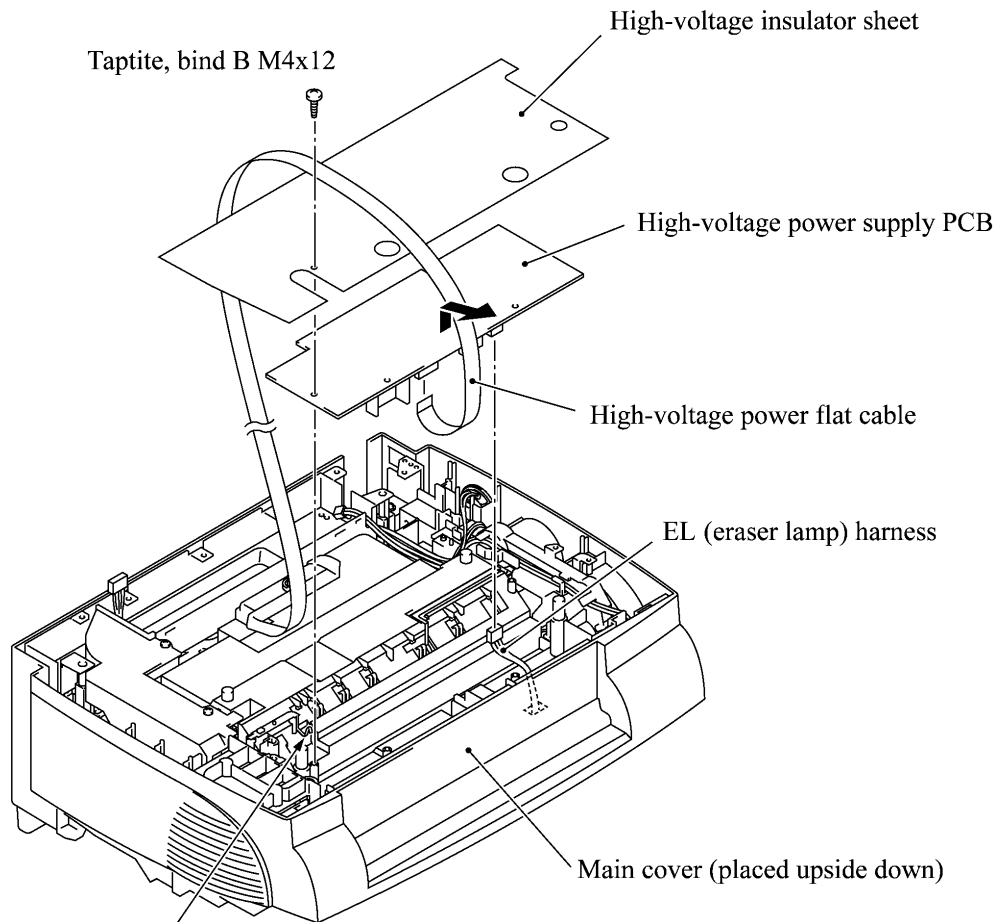

Take care not to bend this high-voltage contact.

■ Reassembling Notes

- Fold the high-voltage power flat cable and route it as illustrated above.
- Before reinstalling the high-voltage power supply PCB, check the high-voltage contacts for any toner particles, paper dust or dirt, and clean them out.

4.1.18 Main-Fan PCB, Duct, and Fan

- (1) Take off the duct by removing the two screws.
- (2) Unlatch the main-fan PCB and lift it up and out of the main cover.
- (3) Disconnect the fan harness from the PCB.
- (4) Take off the fan support by removing the screw.
- (5) Lift up the fan.

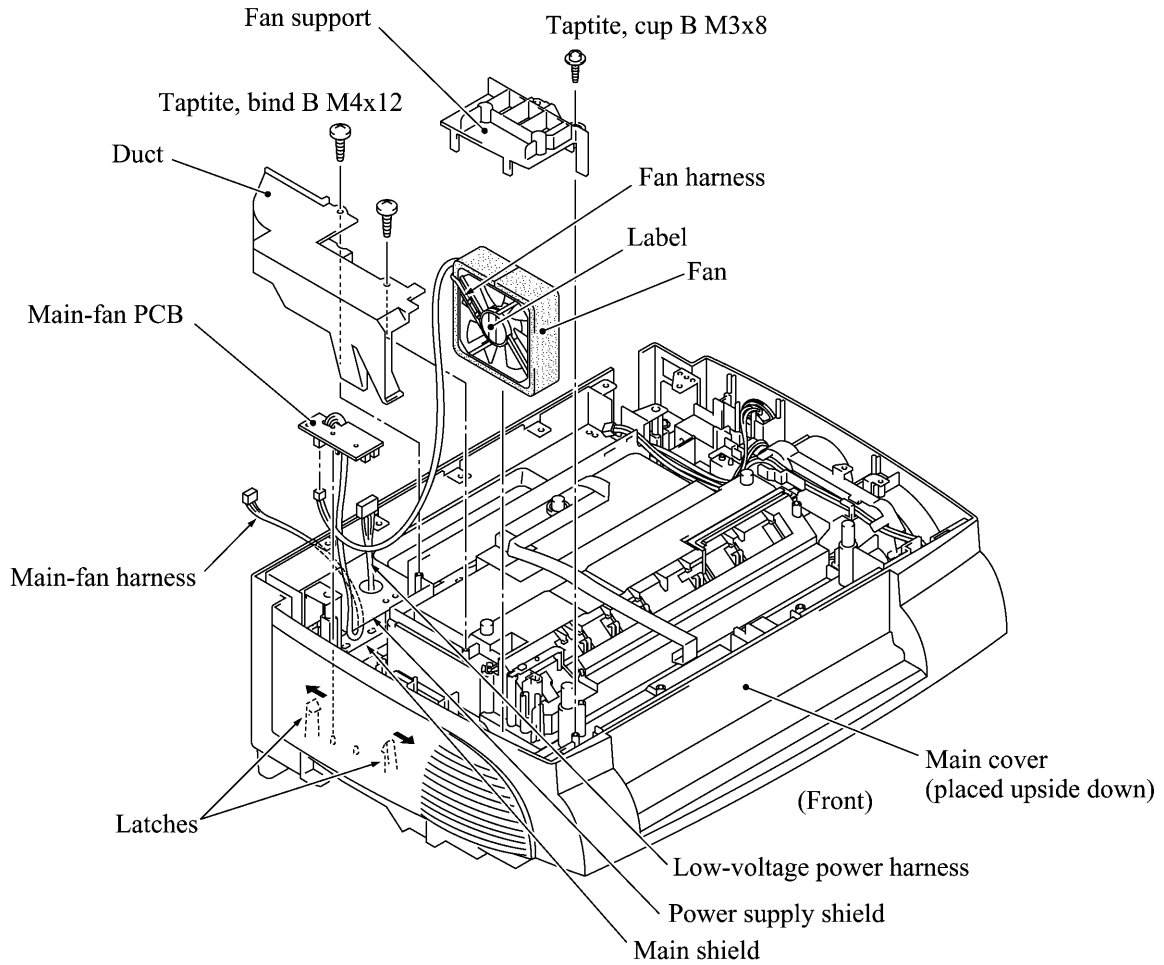

■ Reassembling Notes

- Route the fan harness on the fan as illustrated above.
- Put the fan back into place with the label side facing outwards and with its harness directed as shown above.

4.1.19 Power Supply Shield

- (1) Remove the two screws and lift up the power supply shield.

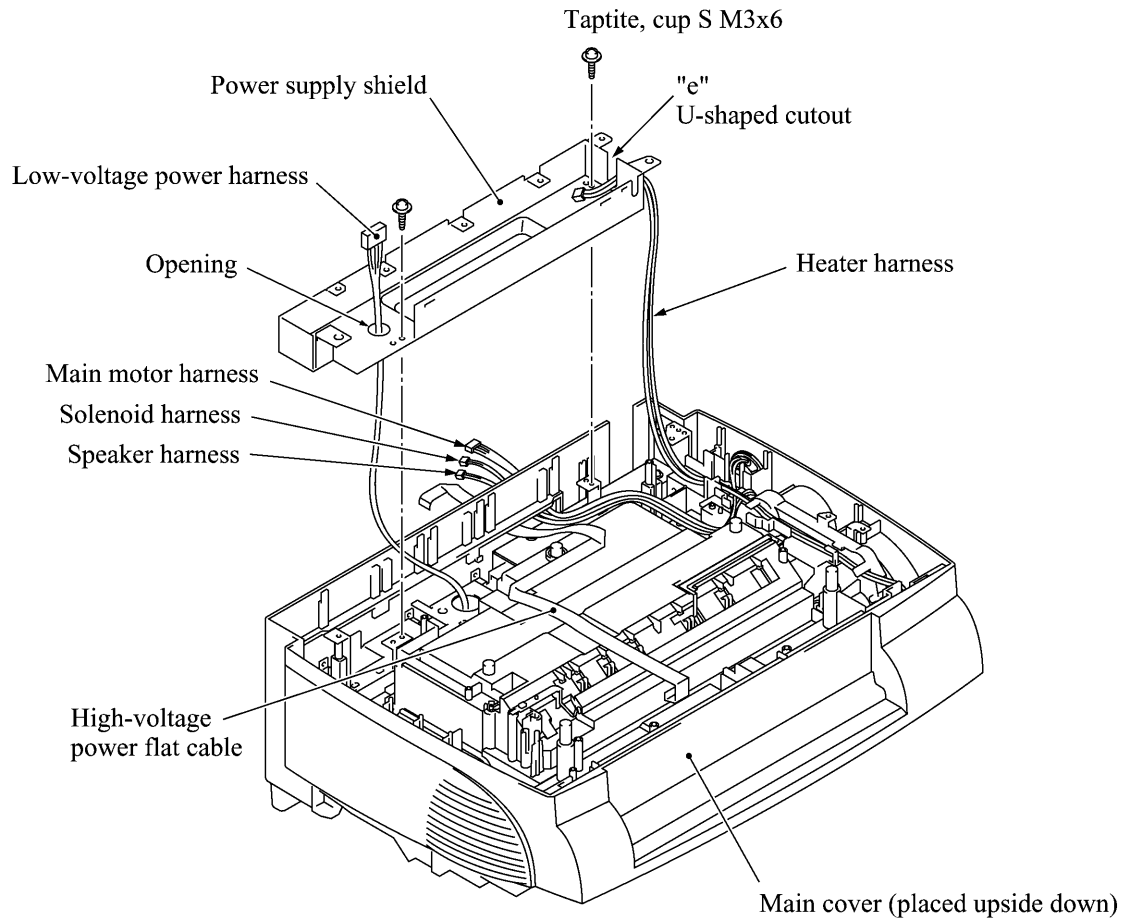

■ Reassembling Notes

- When reinstalling the power supply shield, route the low-voltage power harness through the opening and route the heater harness through U-shaped cutout "e" as shown above.

4.1.20 Speaker

- (1) Pull the speaker spring inwards and pull up the speaker together with the spring.

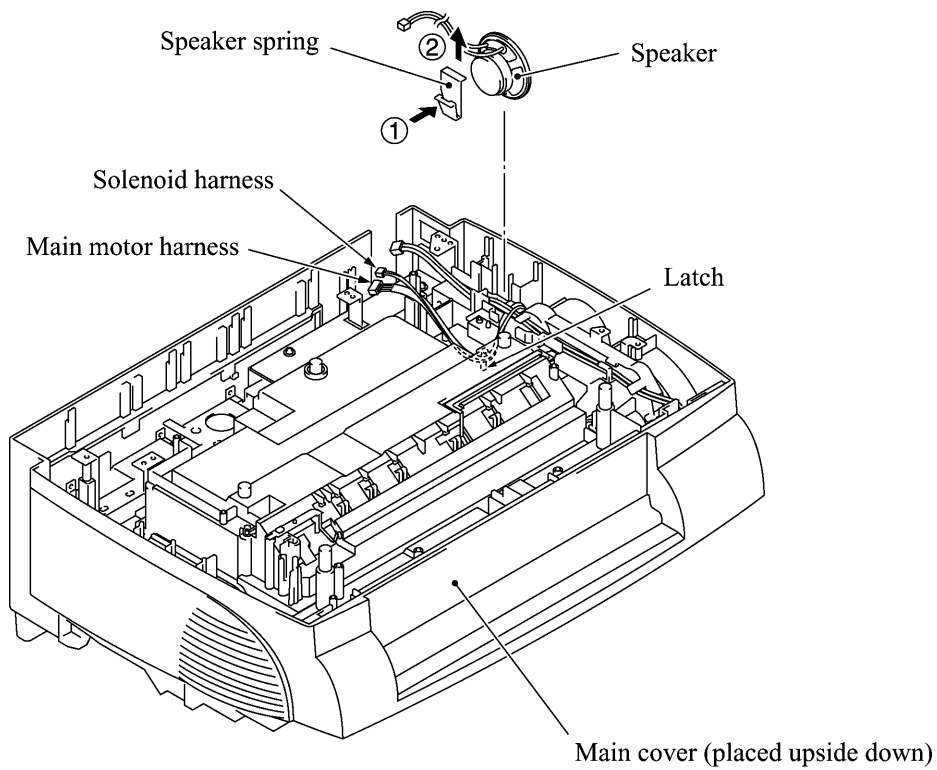

■ Reassembling Notes

- Put the speaker into place with its harness facing up.
- Route the speaker harness through the latch together with the solenoid harness and main motor harness as shown above.

4.1.21 Gear Drive Unit

- (1) Make sure that the heat-fixing unit is removed.
- (2) Take out the heater harness from the cable guides provided on the top of the gear drive unit.
- (3) Remove the four screws and lift up the gear drive unit.

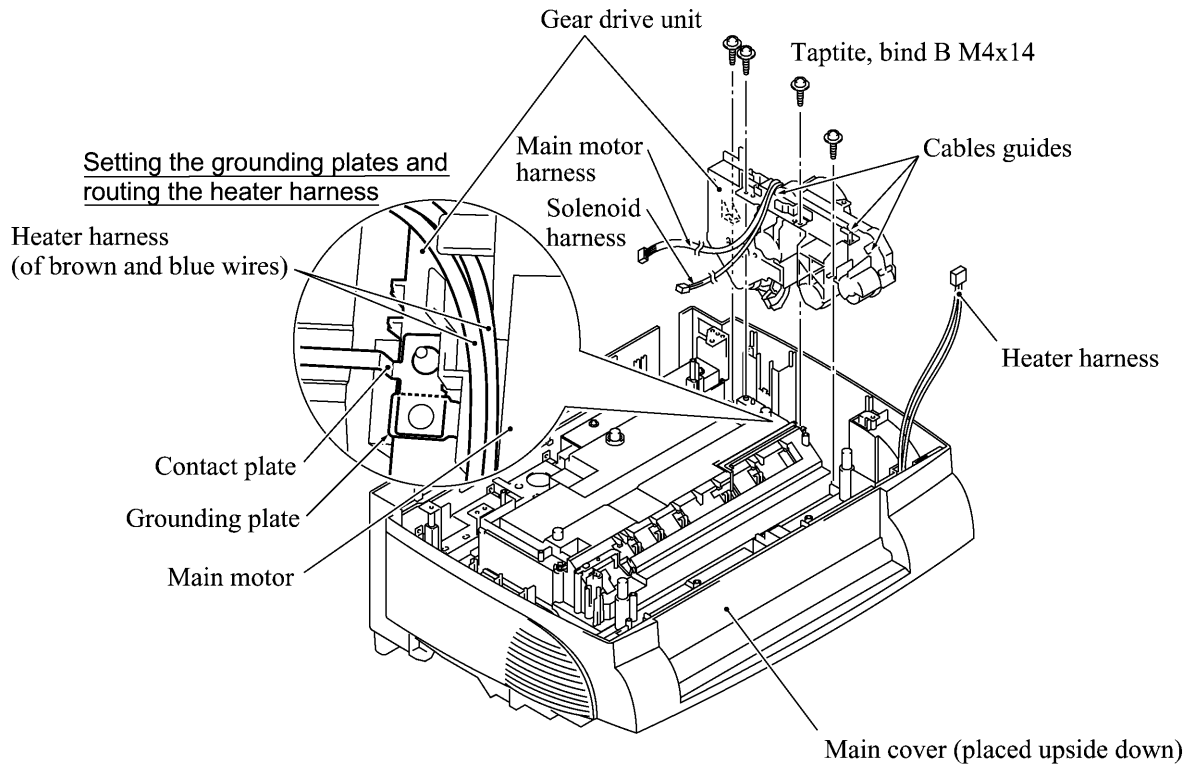

- (4) Remove the two screws and take off the main motor.

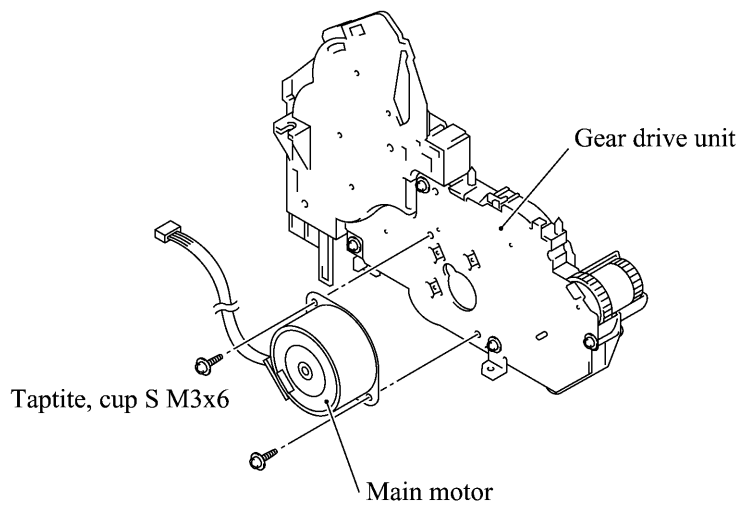

- (5) To take off the paper feed solenoid, solenoid lever, or clutch release lever, remove the two screws.

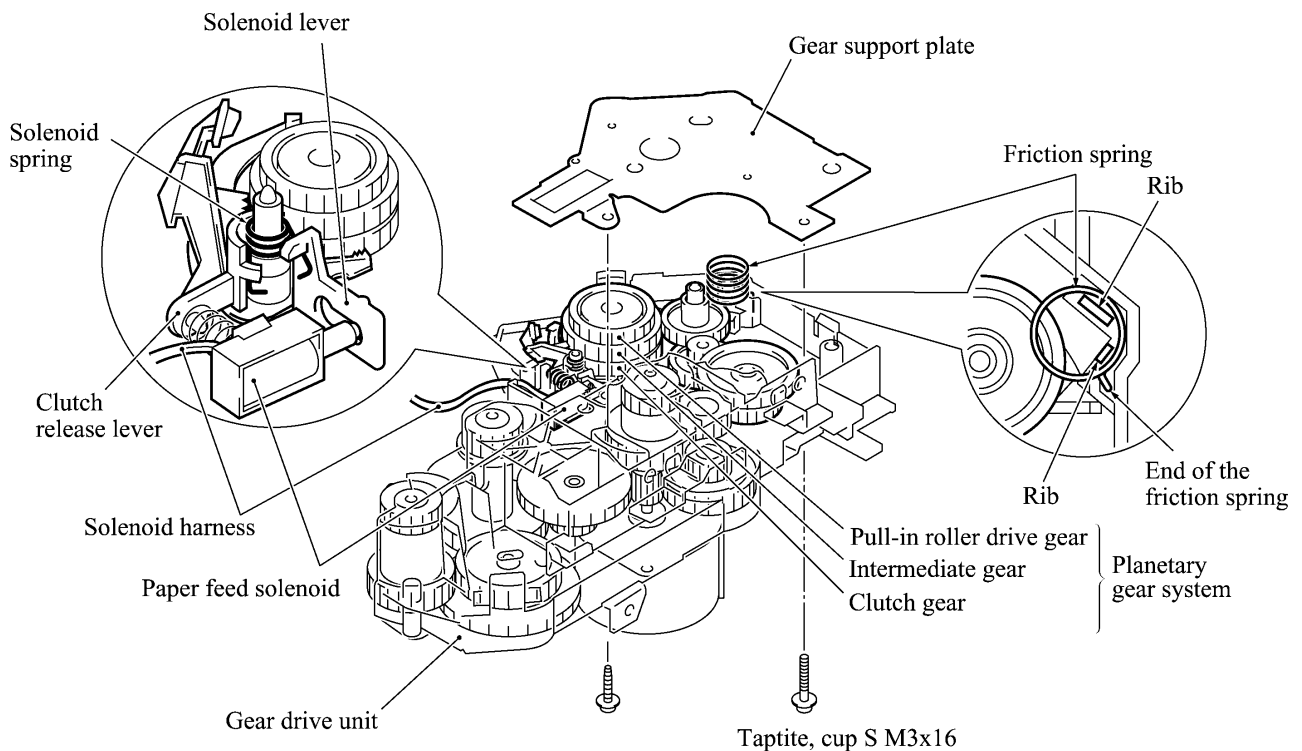

■ Reassembling Notes

- If the friction spring in the gear drive unit slips off, fit the straight end of the spring in the support hole of the gear drive unit as illustrated above.
- When putting the gear drive unit back into the main cover, route the solenoid harness and main motor harness along the outside of the gear drive unit. Be sure to sandwich the grounding plate between the contact plate and gear drive unit. See the illustration given on the previous page.
- After securing the gear drive unit, route the heater harness through the cable guides provided on the top of the gear drive unit.

4.1.22 PCB Support and NCU PCB

- (1) Remove the two screws and lift up the PCB support.

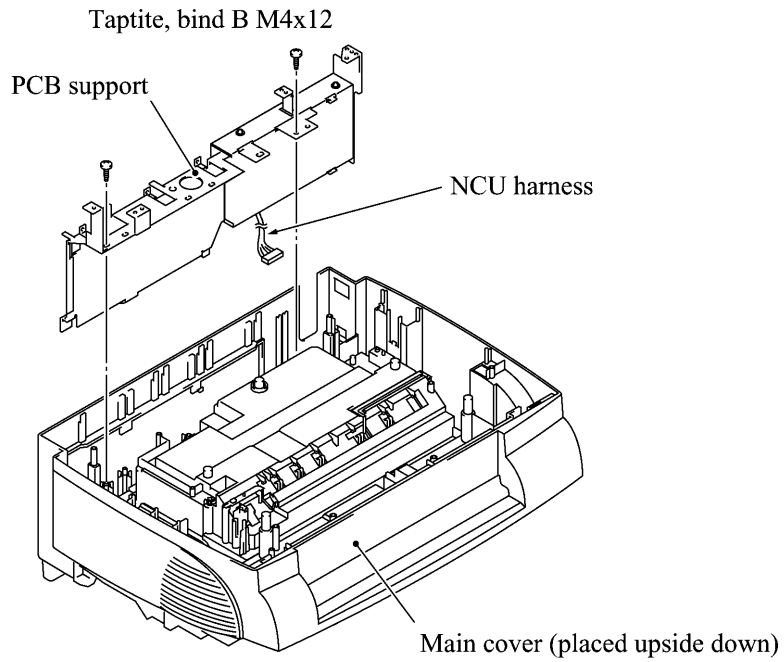

- (2) Remove the two screws and take off the NCU shield.
- (3) Remove the screw and take off the NCU PCB from the PCB support.
- (4) Disconnect the NCU harness.

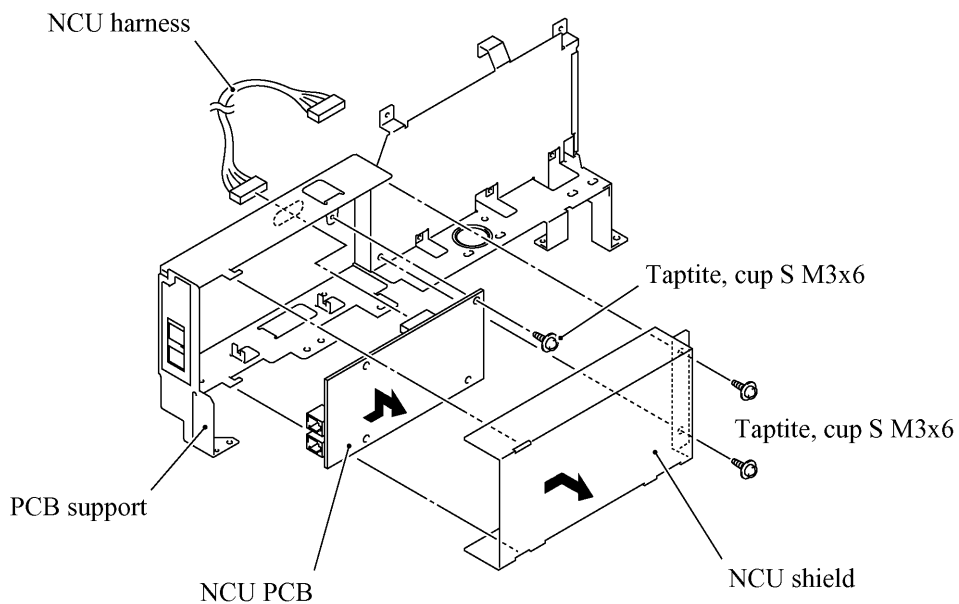

4.1.23 Scanner Grounding Plate

- (1) Make sure that the heat-fixing unit is removed.
- (2) Remove the screw from the scanner grounding plate. (If the bottom plate has not been removed, remove screw "y" also (see page 4-46) that secures both the scanner grounding plate and bottom plate.)
- (3) Slightly lift up the scanner grounding plate.
- (4) You may peel off the anti-static brush from the scanner grounding plate.

NOTE: Once removed, the anti-static brush will become unusable and a new one will have to be put back in.

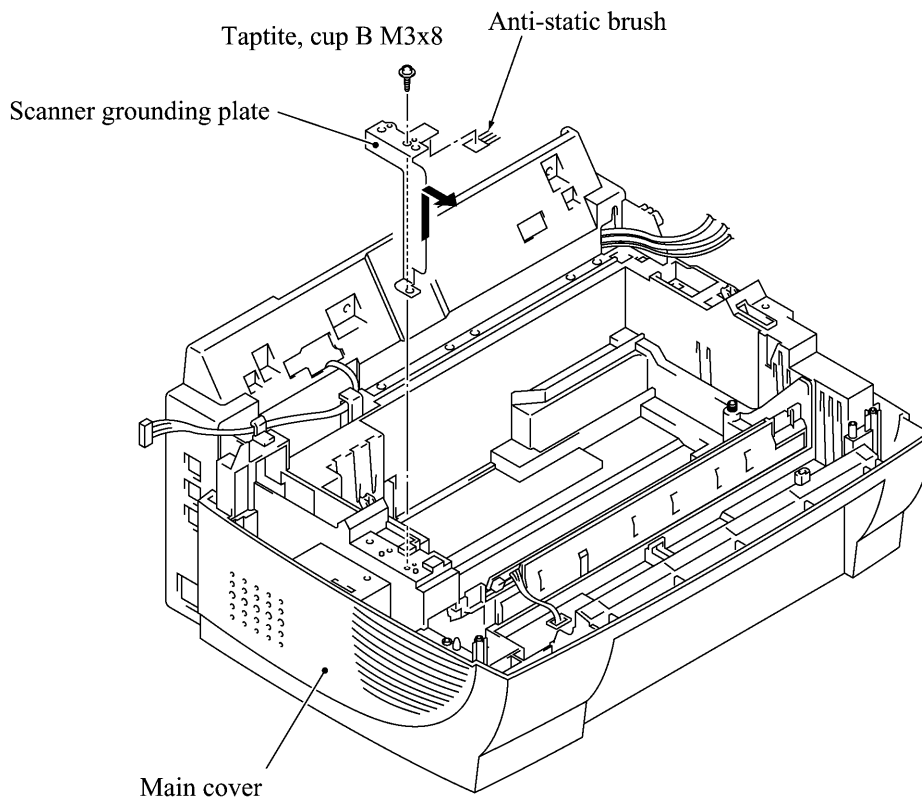

■ Reassembling Notes

- Before attaching a new anti-static brush onto the scanner grounding plate, wipe the surface of the attaching place with a cloth dampened with alcohol.
- When reinstalling the scanner grounding plate, fit it over the two bosses of the main cover.

4.1.24 EL (Eraser Lamp) Board

Only when you need to replace the EL board (which is attached with double-sided adhesive tape), remove it according to the steps below.

- (1) Make sure that the EL harness is disconnected from the high-voltage power supply PCB. (Refer to Subsection 4.1.17.)
- (2) Make sure that the heat-fixing unit is removed.
- (3) Peel off the EL board from the main cover and clear adhesive tape if remaining.

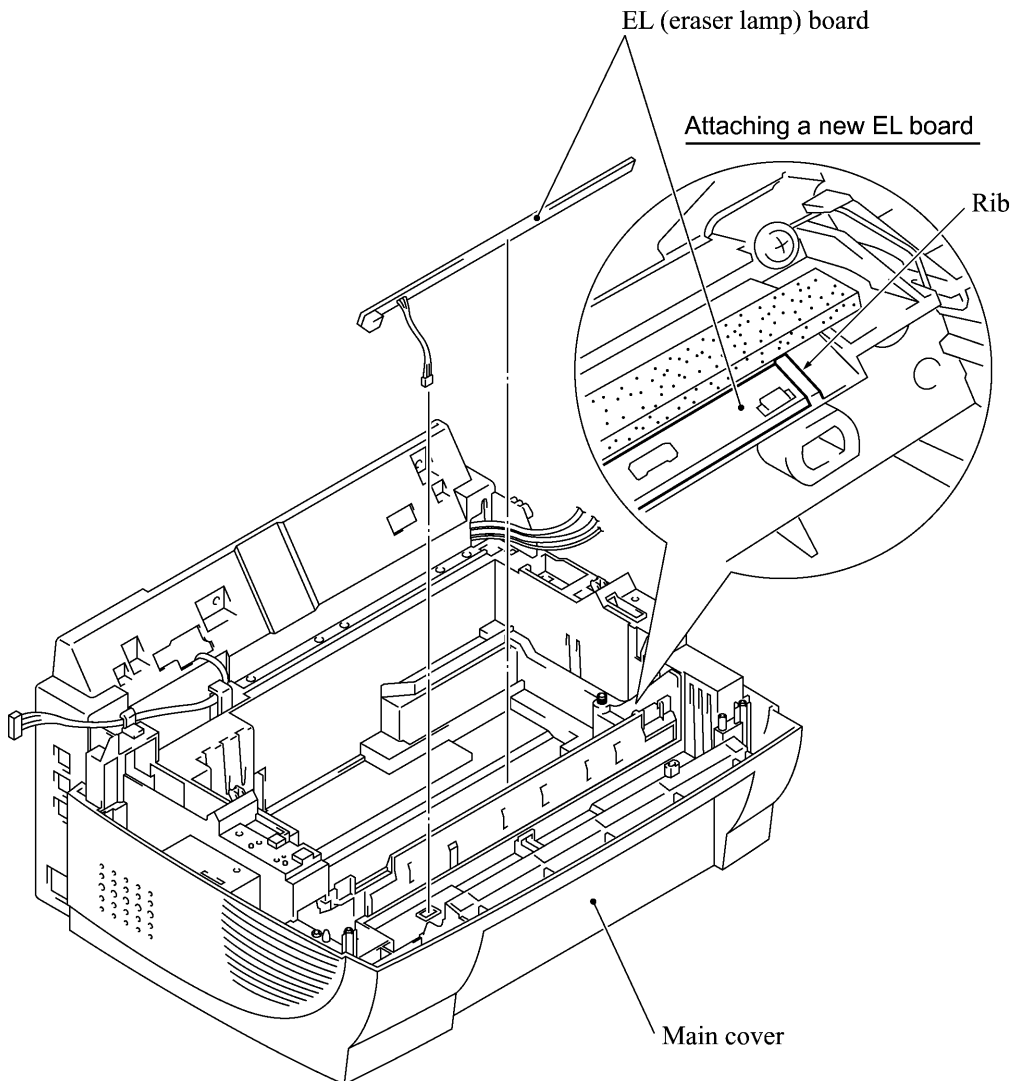

■ Reassembling Notes

- When attaching a new EL board, bring the right end into contact with the rib provided on the main cover.

4.1.25 Harness Routing

Harness routing A: ADF motor harness, document sensor harness, document tray open sensor harness, and grounding wire on the lower ADF chute

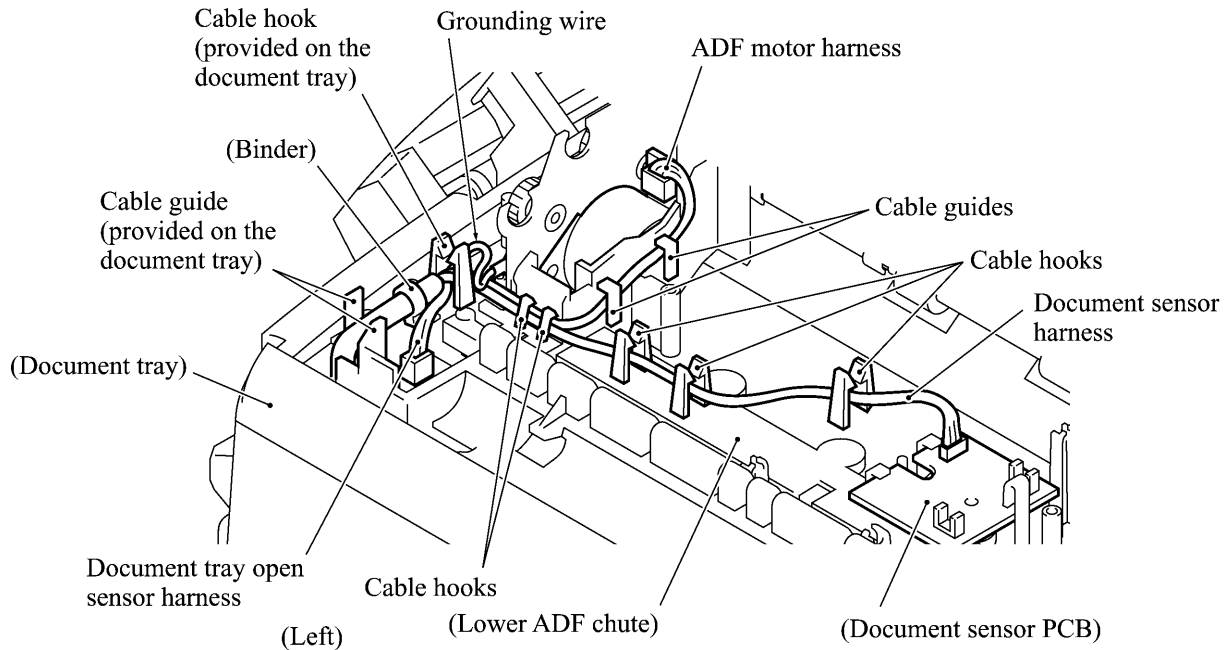

Harness routing B: Relay PCB-related harnesses

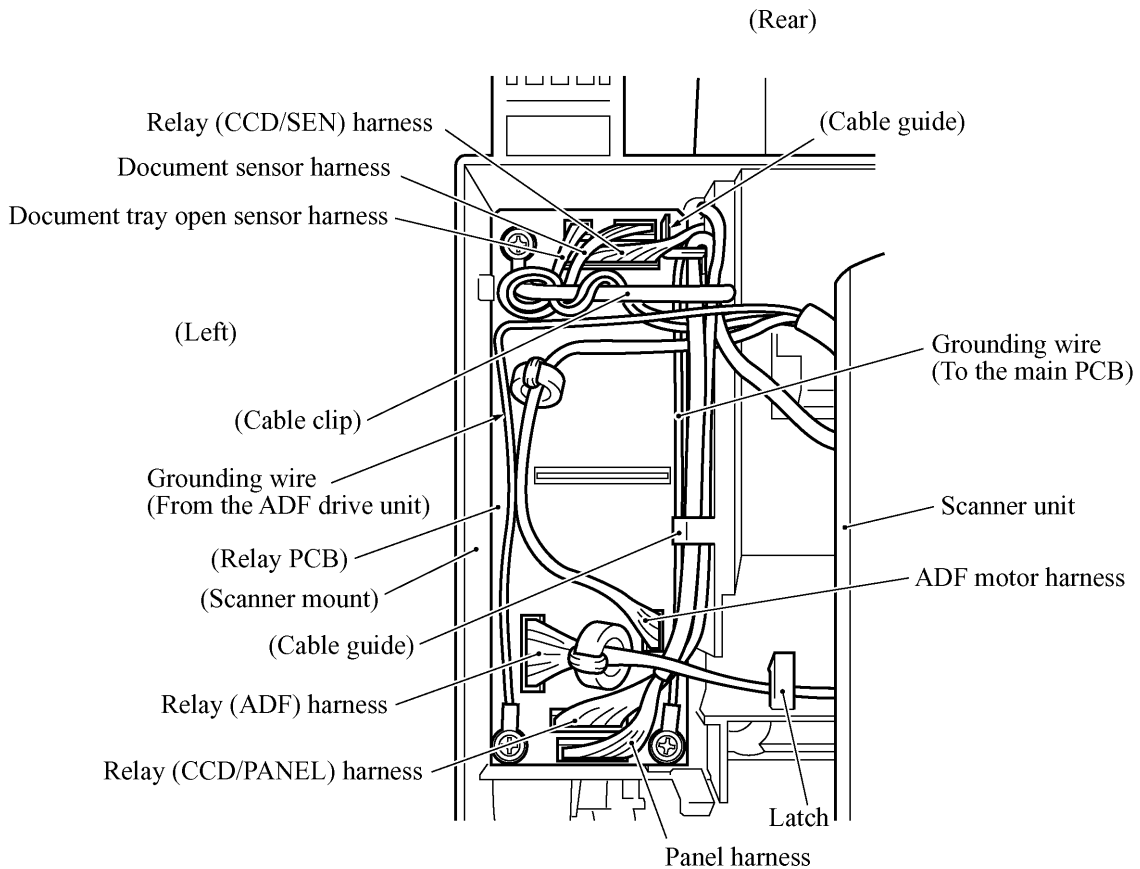

Harness routing C: Relay (ADF) harness on the scanner mount

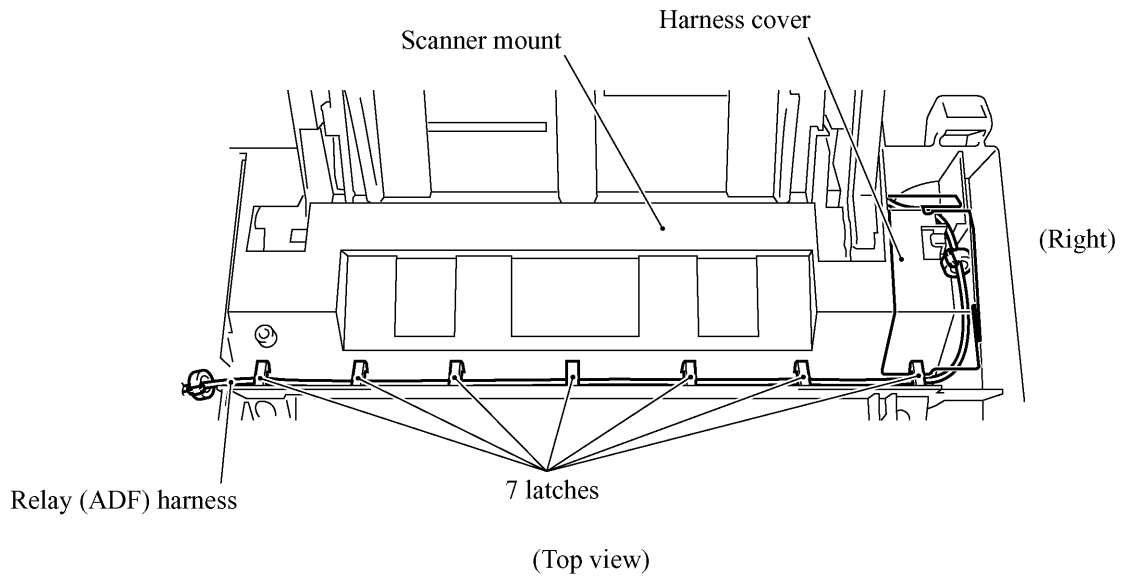

Harness routing D: Main PCB-related harnesses

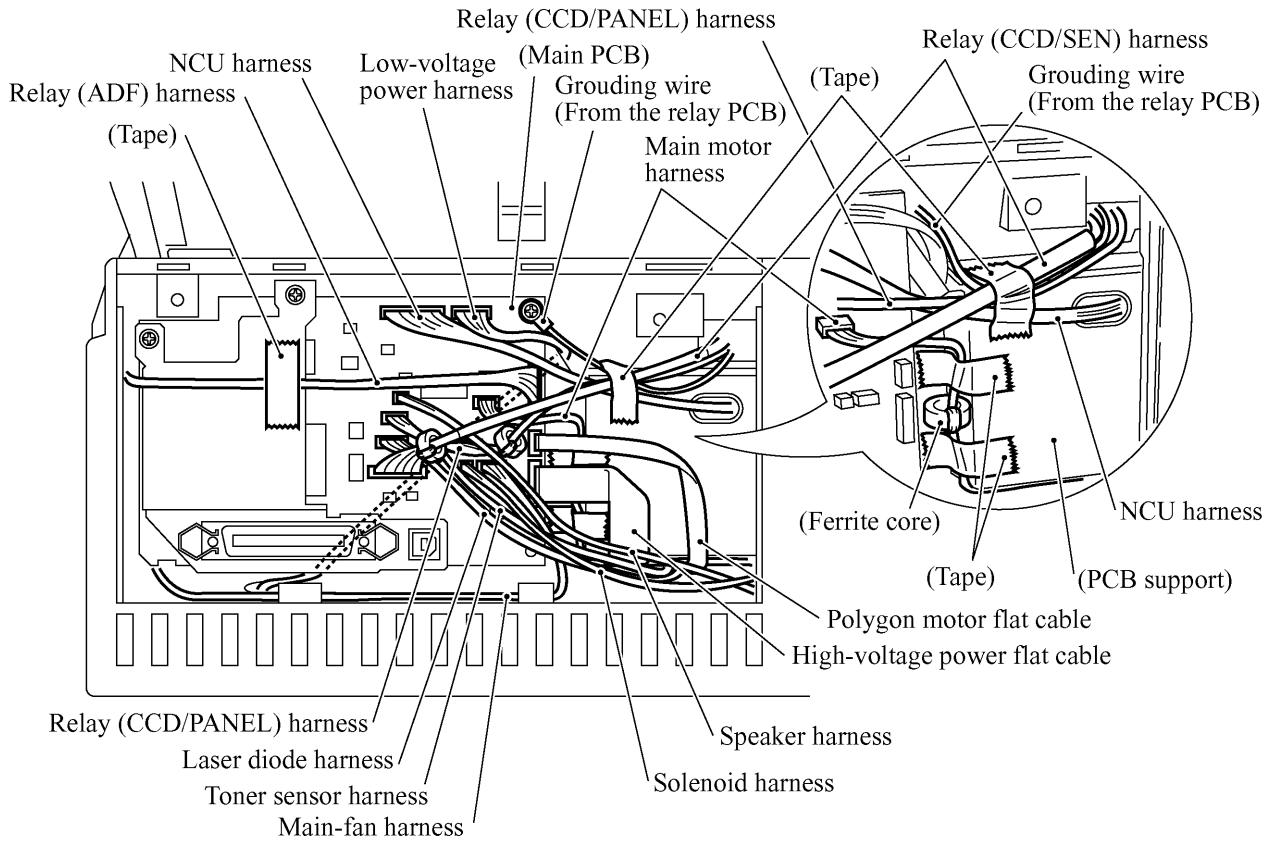

Harness routing E: Relay harnesses on the main cover (after the ASF is removed)

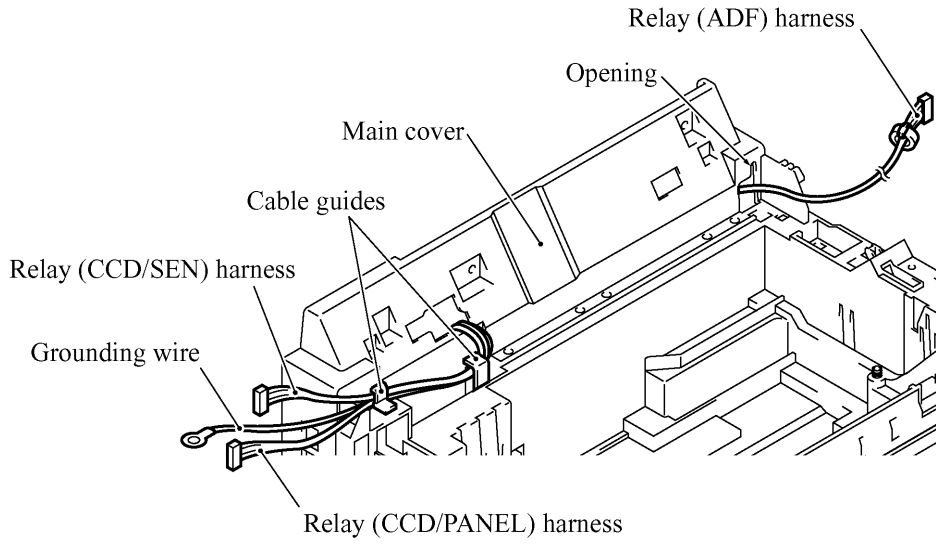

Harness routing F: Heater harness on the main cover (after the heat-fixing unit is removed)

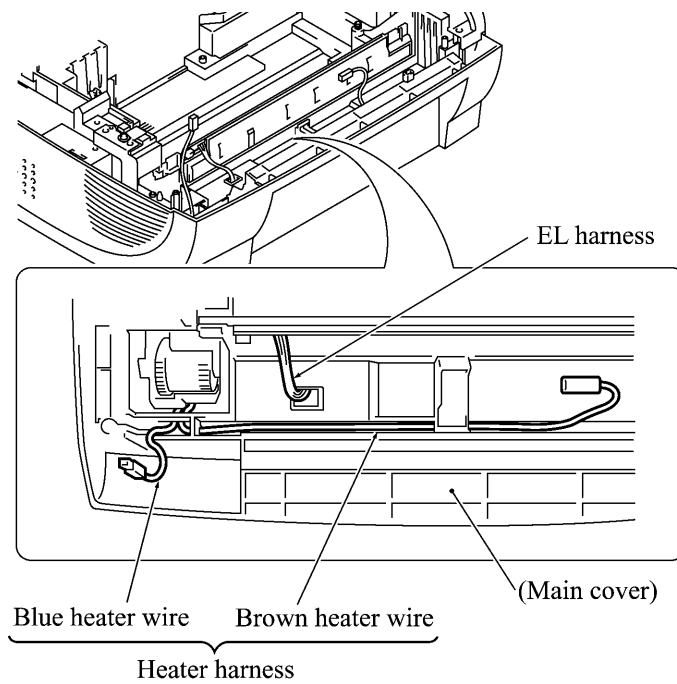

Harness routing G: Laser diode harness, polygon motor flat cable, and toner sensor harness on the laser unit

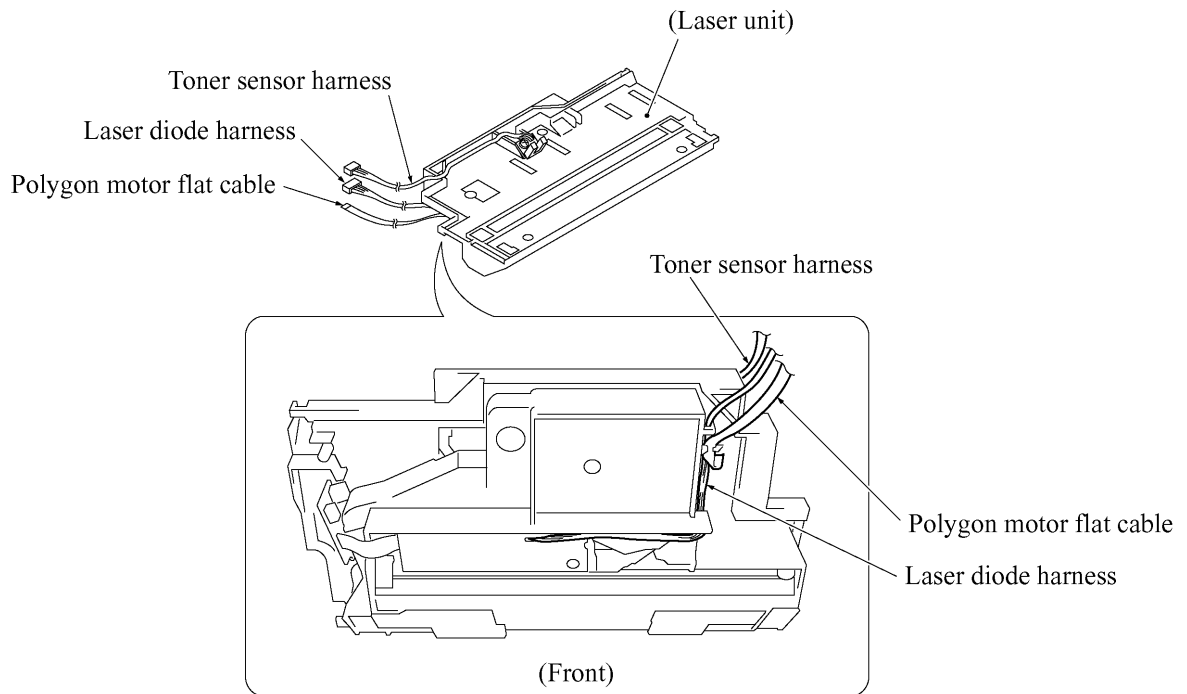

Harness routing H: Harnesses viewed from the bottom of the machine

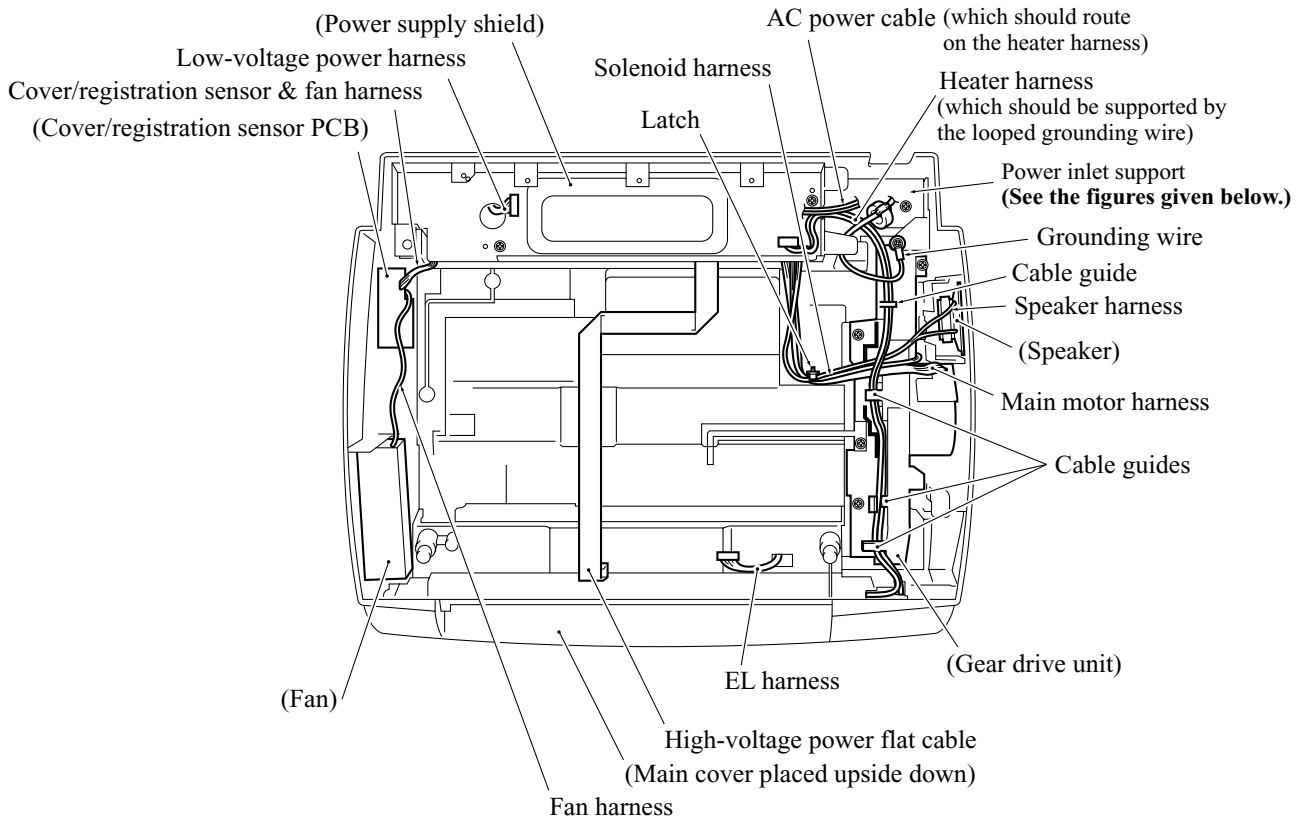

For the power inlet support having no opening

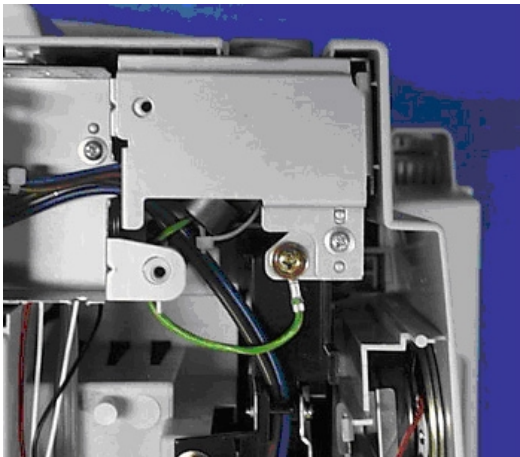

For the power inlet support having an opening

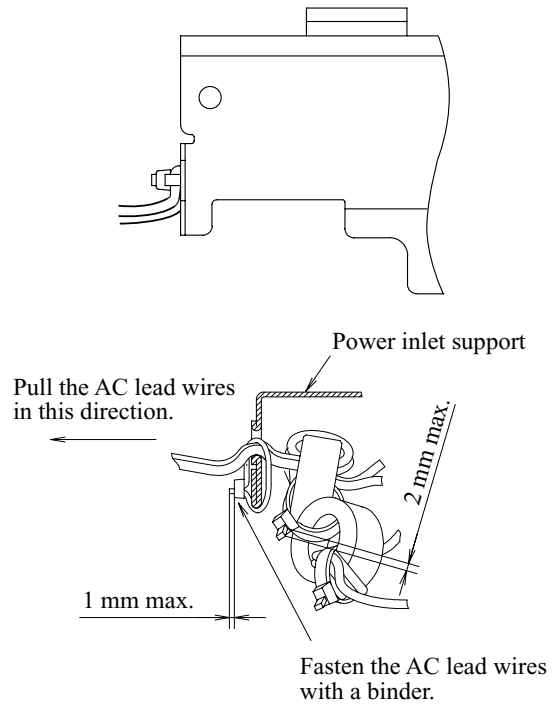

For the harness routing around the power inlet support, see page 4-47-2.

4.1.26 Cleaning of High-voltage Contacts and Grounding Contacts

If any toner particles, paper dust or dirt are on the contacts, clean them out. This will ensure that power flows correctly to enable printing.

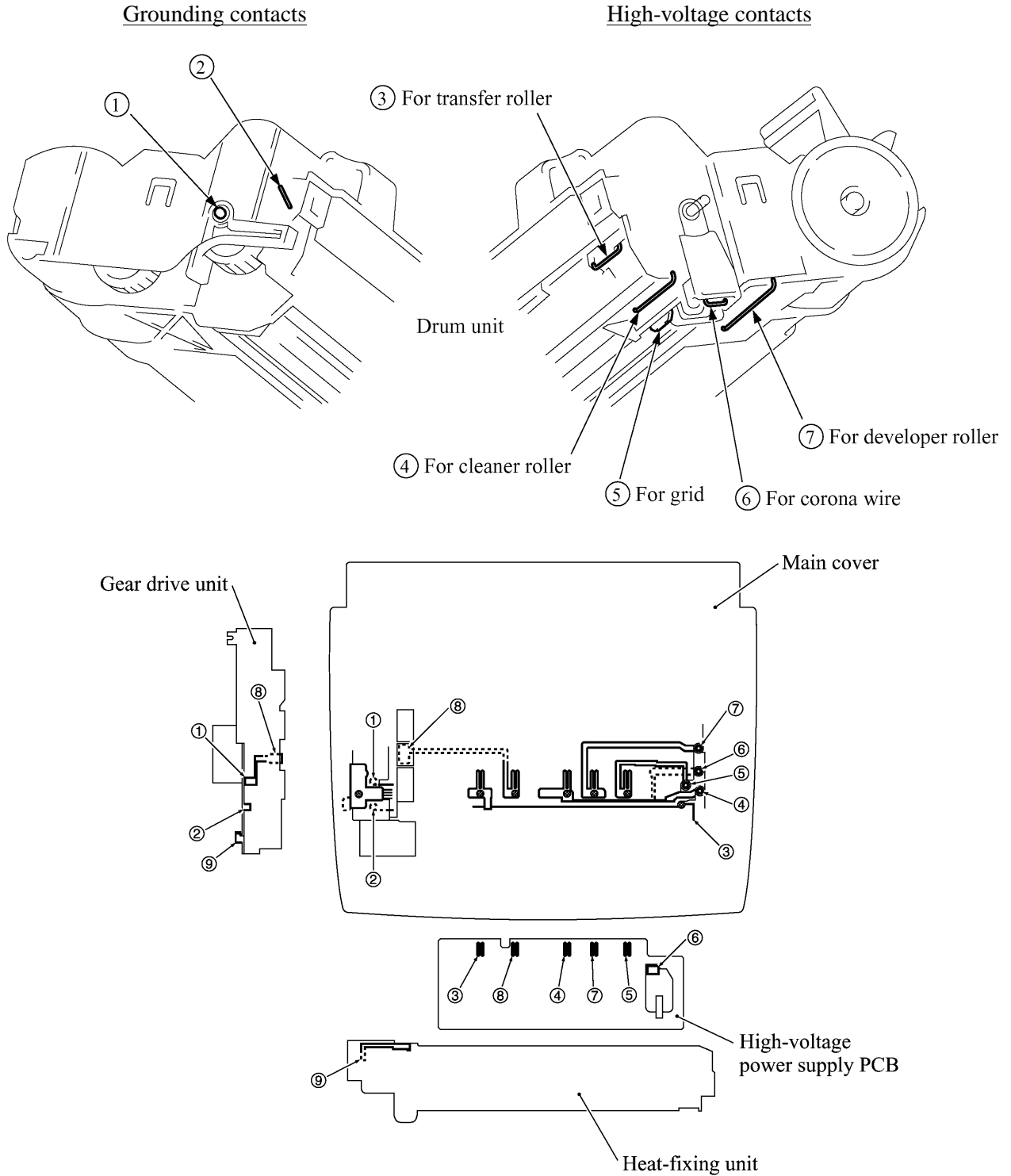

4.2 LUBRICATION

Apply the specified lubricants to the lubrication points as shown below.

Lubricant type (Manufacturer)	Lubricant amount		
	Rice-sized pinch of grease (3 mm dia. ball)	Half rice-sized pinch of grease (2 mm dia. ball)	Thin coat of grease with a brush
Molykote EM-D110 (Dow Corning)	(EMD1)	————	————
Molykote PG662 (Dow Corning)	(PG1)	(PG0.5)	————
Molykote HP-300 (Dow Corning)	————	————	(HP)
FLOIL 951-P32 (Kanto Kasei Ltd.)	(P1)	————	————

[1] Separation pad

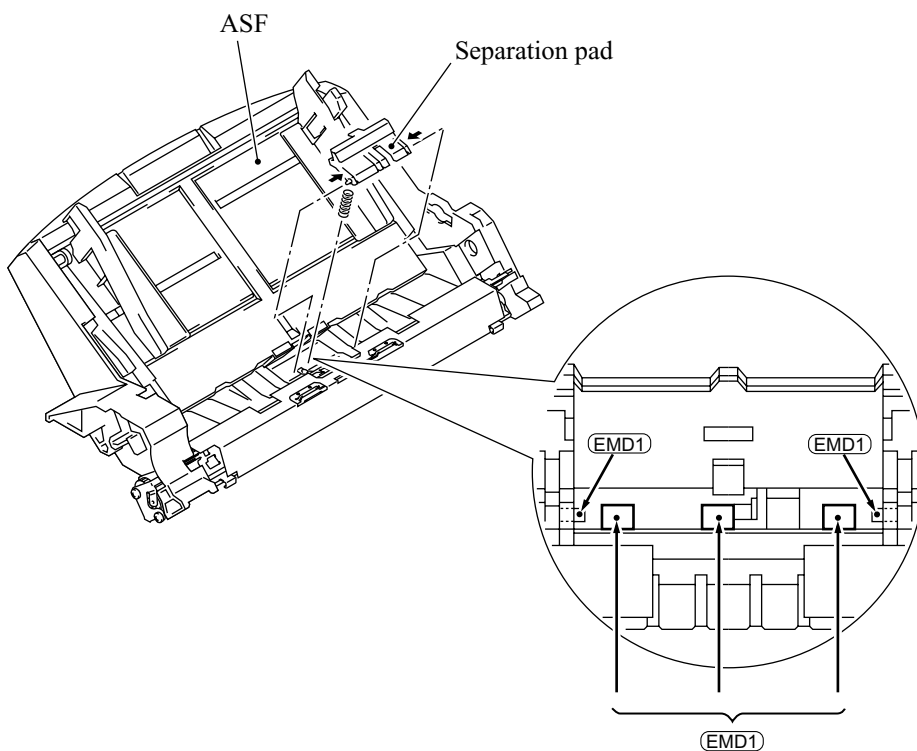

(Apply thin coat of grease to these sections with a brush where the separation pad is to be mounted.)

[2] Separation roller ASSY and document feed roller

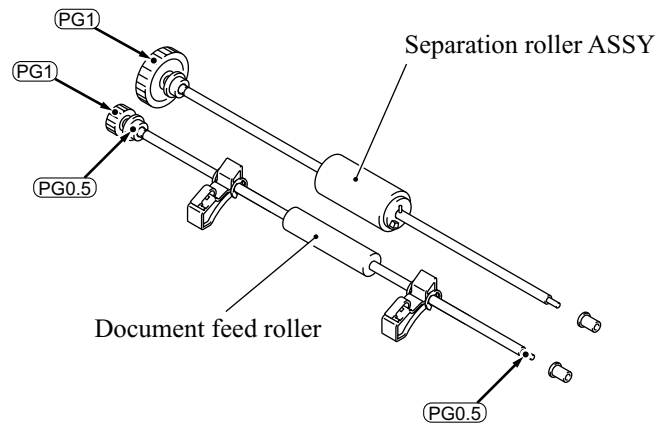

[3] ADF thickness adjuster

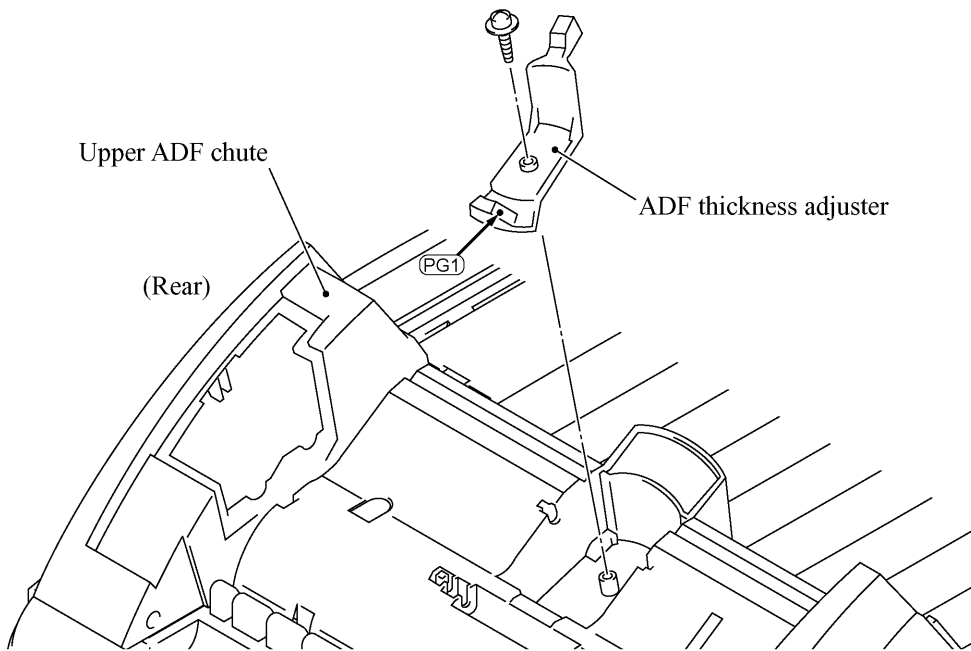

[4] Document ejection roller

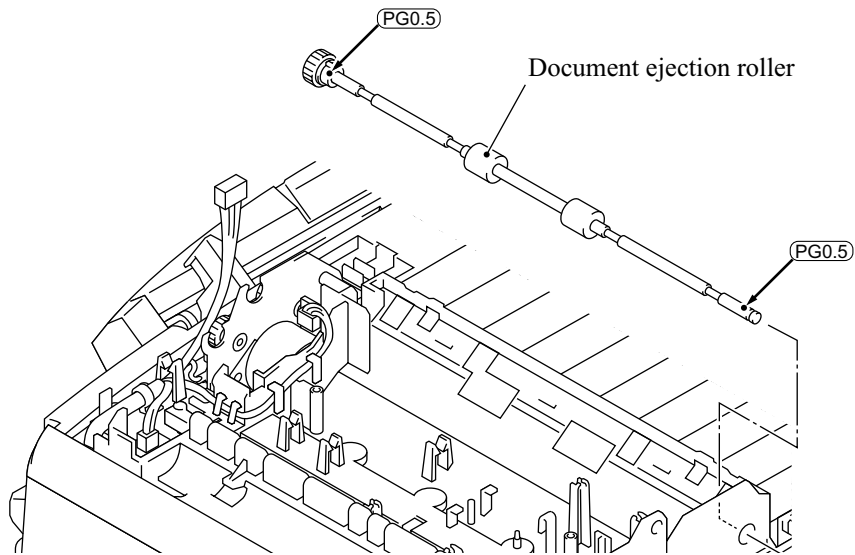

[5] CCD rail in the scanner unit

Apply (P1) to 10 points on the CCD rail and move the CCD unit to the right and left ends of its travel.

NOTE: Keep the CCD drive belt and other parts free from lubricant.

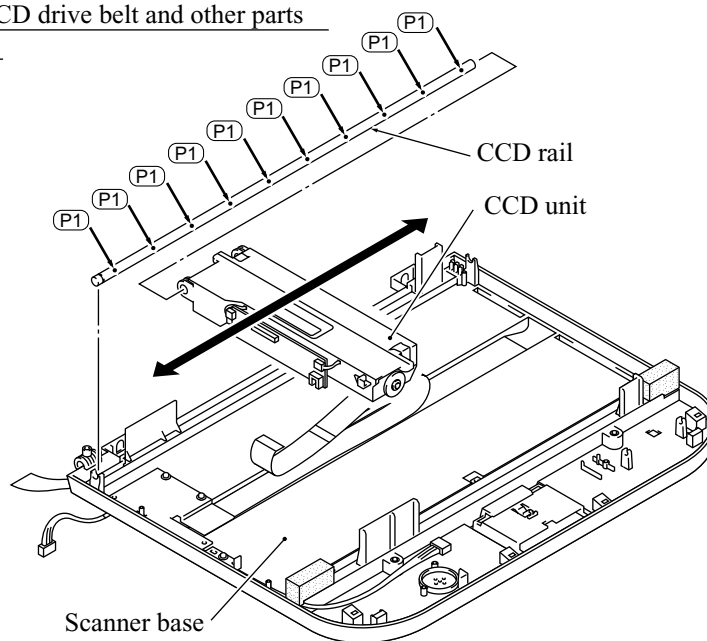

[6] Underside of the scanner unit

Apply thin coat of grease to these three sections () with a brush.

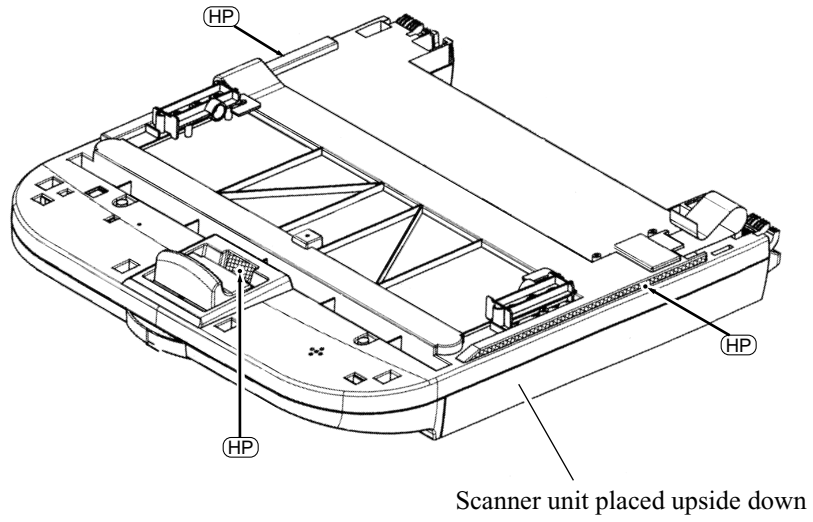

4.3 PERIODICAL REPLACEMENT PARTS

Parts listed below require to be replaced periodically in order to assure the product quality. Even if it seems that those parts are not damaged in appearance, replace them at regular intervals specified below.

The replacement procedure is given in Section 4.1 "DISASSEMBLY/REASSEMBLY."

Parts Name	Q'ty	Replacement Interval (Number of prints in terms of A4 size)	For the replacement procedure, refer to:
Heat-fixing unit	1	50,000 pages	Subsection 4.1.12
Paper pull-in roller	1	50,000 pages	Subsection 4.1.11 (Illustration on page 4-36)
Separation pad ASSY	1	50,000 pages	

NOTE: The above table gives only the reference values.

4.4 MTBF/MTTR

The meantime between failures (MTBF) and meantime to repair (MTTR) of this machine are listed below.

MTBF: At least 10,000 hours

MTTR: Average 30 minutes per repair

CHAPTER 5

MAINTENANCE MODE

CHAPTER 5 MAINTENANCE MODE

CONTENTS

5.1	ENTRY INTO THE MAINTENANCE MODE	5-1
5.2	LIST OF MAINTENANCE-MODE FUNCTIONS	5-2
5.3	DETAILED DESCRIPTION OF MAINTENANCE-MODE FUNCTIONS	5-4
5.3.1	EEPROM Parameter Initialization	5-4
5.3.2	Printout of Scanning Compensation Data	5-5
5.3.2A	Movement of CCD Unit to the Transport Position	5-1
5.3.3	ADF Performance Test	5-7
5.3.4	Test Pattern 1	5-8
5.3.5	Firmware Switch Setting and Printout	5-9
5.3.6	Operational Check of LCD	5-12
5.3.7	Operational Check of Control Panel PCB	5-12
5.3.8	Sensor Operational Check	5-14
5.3.9	Fine Adjustment of Scanning Start/End Position	5-15
5.3.10	CCD Scanner Area Setting	5-16
5.3.11	EEPROM Customizing	5-16
5.3.12	Display of the Machine's Log Information	5-17
5.3.13	Machine Error Code Indication	5-18
5.3.14	Output of Transmission Log to the Telephone Line (Not applicable to machines w/o fax)	5-18
5.3.15	Cancellation of the Memory Security Mode (Applicable to the European version w/ fax only)	5-19

5.1 ENTRY INTO THE MAINTENANCE MODE

For machines w/ fax

To make the machine enter the maintenance mode, press the **Menu**, *****, **2**, **8**, **6**, and **4** keys in this order.

|← Within 2 seconds →|

For machines w/o fax

To make the machine enter the maintenance mode, press the **Menu**, **0**, **2**, **8**, **6**, and **4** keys in this order.

|← Within 2 seconds →|

The machine beeps for approx. one second and displays "■■ MAINTENANCE ■■■" on the LCD, indicating that it is placed in the initial stage of the maintenance mode, a mode in which the machine is ready to accept entry from the keys.

To select one of the maintenance-mode functions listed in Section 5.2, enter the corresponding 2-digit function code with the numerical keys on the control panel. (The details of each maintenance-mode function are described in Section 5.3.)

- NOTES:**
- Pressing the **9** key twice in the initial stage of the maintenance mode makes the machine exit from the maintenance mode, restoring it to the standby state.
 - Pressing the **Stop** key after entering only one digit restores the machine to the initial stage of the maintenance mode.
 - If an invalid function code is entered, the machine resumes the initial stage of the maintenance mode.

5.2 LIST OF MAINTENANCE-MODE FUNCTIONS

Maintenance-mode Functions

Function Code	Function	Reference Subsection (Page)
01	EEPROM Parameter Initialization	5.3.1 (5-4)
05	Printout of Scanning Compensation Data	5.3.2 (5-5)
06	Movement of CCD Unit to the Transport Position	5.3.2A (5-6-1)
08	ADF* Performance Test	5.3.3 (5-7)
09	Test Pattern 1	5.3.4 (5-8)
10	Firmware Switch Setting	5.3.5 (5-9)
11	Printout of Firmware Switch Data	5.3.5 (5-11)
12	Operational Check of LCD	5.3.6 (5-12)
13	Operational Check of Control Panel PCB (Check of Keys and Buttons)	5.3.7 (5-12)
32	Sensor Operational Check	5.3.8 (5-14)
54	Fine Adjustment of Scanning Start/End Position	5.3.9 (5-15)
55	CCD Scanner Area Setting	5.3.10 (5-16)
74	EEPROM Customizing	5.3.11 (5-16)
80	Display of the Machine's Log Information	5.3.12 (5-17)
82	Machine Error Code Indication	5.3.13 (5-18)
87	Output of Transmission Log to the Telephone Line	5.3.14 (5-18)
91	EEPROM Parameter Initialization (except the telephone number storage area)	5.3.1 (5-4)
99	Exit from the Maintenance Mode	---- (5-1)

* ADF: Automatic document feeder

----- **IMPORTANT** -----

Basically, the maintenance-mode functions listed on the previous page should be accessed by service personnel only. However, you may allow end users to access some of these under the guidance of service personnel (e.g., by telephone).

The user-accessible functions (codes 06, 10, 11, 12, 54, 80, 82, 87 and 91) are shaded in the table given on the previous page. Function code 10 accesses the firmware switches, each of which has eight selectors. You should not allow end users to access all of those selectors, but you may allow them to access user-accessible selectors which are shaded in the firmware switch tables in Appendix 2.

The service personnel should instruct end users to follow the procedure given below.

(1) For MFC6800

Press the **Menu** and **Receive Mode** keys in this order.

NOTE: The **Receive Mode** key is inoperable during standby for redialing and timer.

For MFC9180

Press the **Menu** and **Fax Resolution** keys in this order.

For DCP1000 and MFC9160

Press the **Menu** and **Sort** keys in this order.

The LCD clears the current display.

- (2) Press the **0** key.
- (3) Enter the desired function code (06, 10, 11, 12, 54, 80, 82, 87, or 91) with the numerical keys.
For function code 10, access the desired firmware switch according to the operating procedure described in Appendix 2.
- (4) To make the machine return to the standby state, press the **Stop** key.

For machines w/ fax

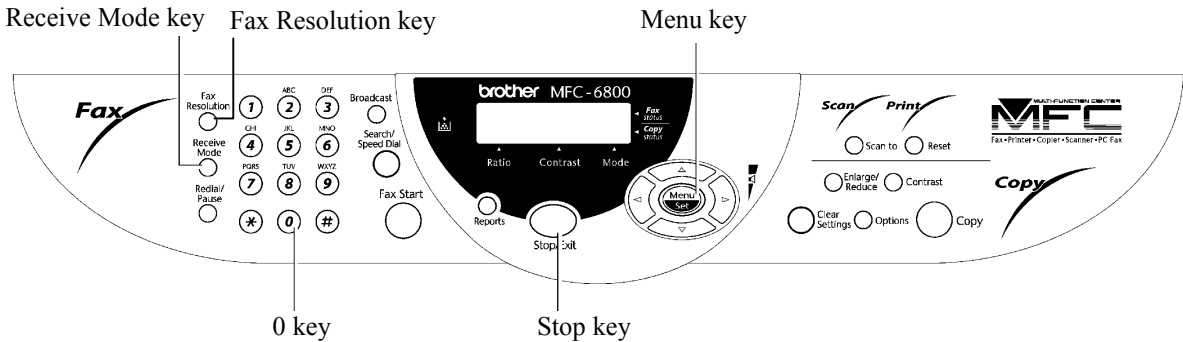

For machines w/o fax

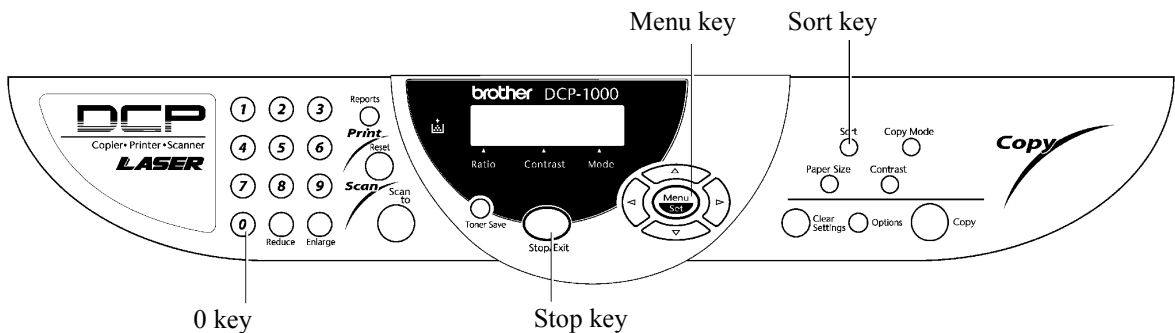

5.3 DETAILED DESCRIPTION OF MAINTENANCE-MODE FUNCTIONS

5.3.1 EEPROM Parameter Initialization

■ Function

The machine initializes the parameters, user switches, and firmware switches registered in the EEPROM, to the initial values. Entering the function code 01 initializes all of the EEPROM areas, but entering 91 does not initialize some areas, as listed below.

Function code	01	91
Data item		
Maintenance-mode functions	All of these will be initialized	These will be initialized
User switches		
Firmware switches		
Remote activation code		
Activity report		These will <u>not</u> be initialized
Station ID data		
Outside line number		
Telephone function registration		
Speed dialing		
Group dialing		
Received FAX messages temporarily stored in the flash memory (Not applicable to the American version)	These will <u>not</u> be initialized. (Note that the first digit of the 4-digit customizing code will be initialized to "0." If the code is <u>1</u> 001, for example, it will be initialized to <u>0</u> 001.)	
EEPROM customizing code (4-digit)		

NOTE: If you replace the main PCB with one used for any other machine, carry out this procedure and then customize the EEPROM (maintenance-mode function code 74 in Subsection 5.3.11).

■ Operating Procedure

- (1) Press the **0** and **1** keys (or the **9** and **1** keys according to your need) in this order in the initial stage of the maintenance mode.
The "PARAMETER INIT" will appear on the LCD.
- (2) Upon completion of parameter initialization, the machine returns to the initial stage of the maintenance mode.

5.3.2 Printout of Scanning Compensation Data

■ Function

The machine prints out the white and black level data for scanning compensation.

■ Operating Procedure

Do not start this function merely after powering on the machine but start it after carrying out a sequence of scanning operation. Unless the machine has carried out any scanning operation, this function cannot print out correct scanning compensation data. This is because at the start of scanning operation, the machine initializes white and black level data and takes in the scanning compensation reference data.

- (1) Press the **0** and **5** keys in this order in the initial stage of the maintenance mode.
The "WHITE LEVEL 1" will appear on the LCD.
- (2) The machine prints out the scanning compensation data list containing the following:
 - a) A/D converter reference level for high value (3 bytes for green, blue, and red)
 - b) A/D converter reference level for low value (3 bytes for green, blue, and red)
 - c) Dark level offset data (3 bytes for green, blue, and red)
 - d) Gain control data (3 bytes for green, blue, and red)
 - e) Voltage division data (3 bytes for green, blue, and red)
 - f) Compensation data for background color (1 byte)
 - g) 2-value quantization black level data (3 bytes for green, blue, and red)
 - h) 2-value quantization white level data (4912 bytes for green)
 - i) 2-value quantization white level data (4912 bytes for blue)
 - j) 2-value quantization white level data (4912 bytes for red)
- (3) Upon completion of recording of the compensation data list, the machine returns to the initial stage of the maintenance mode.

NOTE: If any data is abnormal, its code will be printed in inline style, as shown on the next page.

1999-01-30-21:19

a) 40044708 : d0
40044709 : d0
4004470a : d0

b) 4004470d : 10 10 10 10 10 10 10 10 10 10 10 10 10 10 10 10
4004470e : 10 10 10 10 10 10 10 10 10 10 10 10 10 10 10 10
4004470f : 10 10 10 10 10 10 10 10 10 10 10 10 10 10 10 10

c) 40044712 : 50786400 : 89 87 88 88 8c 88 8b 89 8a 88 8c 8a 89 89 8a 88
40044713 : 50786410 : 8a 8a 8a 88 8b 8a 8a 8a 8b 88 8a 87 8a 8a 8b 89
40044714 : 50786420 : 8b 89 8b 8a 8c 89 8b 88 88 8d 88 8b 89 88 8b

d) 40044717 : 50786000 : 8c 8b 89 89 8b 8c 89 8a 8a 89 8c 89 87 88 89 86
40044718 : 50786430 : 89 89 88 87 89 88 88 88 86 87 87 86 88 89 86
40044719 : 507860a0 : 89 87 8a 88 89 87 89 89 88 89 88 87 89 89

e) 4004471d : 507860b0 : 89 89 88 8a 8a 89 88 87 86 88 88 85 89 88 88
4004471e : 507860c0 : 88 89 8a 86 89 88 89 87 89 89 8a 89 8a 86 88 89
4004471f : 507860d0 : 8b 89 88 89 89 88 88 8a 88 8b 88 8a 8b 8c 8a

f) 4004471c : 507860e0 : 8b 89 8a 8a 8c 8a 8a 8b 8c 8a 8a 8a 8a 8b 8c 8a
50786100 : 8b 8a 8a 8b 8c 8a 89 8c 8b 8a 8d 8a 8a 8b 8b 88
50786110 : 8b 89 89 8a 8a 88 8c 8a 8a 89 8c 89 8a 89 8b 88
50786120 : 8a 8a 88 8b 8c 8a 8a 8b 8d 8b 8d 8a 8a 8b 8c 88
50786130 : 8b 8a 8d 8b 8c 8a 8d 8c 8d 8b 8c 8d 8d 8b 8a 8b
50786140 : 8f 8c 8e 8c 91 8b 8d 8c 8d 8c 8d 8c 8d 8c 8d 8c

g) 50792000 : 50786150 : 8e 8c 8e 8c 8e 8b 8c 8d 8c 8d 8c 8d 8c 8d 8c 8d
50792100 : 50786160 : 8d 8e 8e 8b 8b 8b 8b 8b 8b 8b 8b 8b 8b 8b 8b 8b
50792200 : 50786510 : 8f 8b 8d 8c 8e 8d 8c 8e 8d 8c 8e 8d 8c 8e 8d 8c

50786170 : 50786180 : 7c 7b 7d 7c 7a 7c 7b 7d 7c 7a 7c 7b 7d 7c 7a
50786190 : 507861e0 : 7a 7f 7c 7d 7d 7d 7d 7d 7d 7c 7e 7e 7f 7d 7c 7d 7c
507861b0 : 5078ec40 : 7a 7f 7c 7d 7d 7d 7d 7d 7d 7c 7e 7e 7f 7d 7c 7d 7c

5078f000 : 72 72 73 70 72 72 6f 72 73 73 72 72 72 6f 70 71
5078f010 : 71 72 72 70 72 70 71 73 73 72 74 72 73 6f 71 70
5078f020 : 73 71 72 70 72 73 73 72 73 73 75 72 73 72 72 73
5078f030 : 71 72 74 72 71 73 72 70 73 71 71 72 6f 6d 70 6f
5078f040 : 72 71 70 71 71 71 70 6f 72 72 6f 6f 70 71 70 72
5078f050 : 71 70 71 71 74 72 71 72 72 6f 72 71 72 6e 70
5078f060 : 71 72 73 72 71 74 71 73 72 72 75 72 72 71 72 72
5078f070 : 73 71 70 70 5e 70 71 71 70 70 72 70 71 6f 72 70
5078f080 : 6f 70 71 72 72 71 71 72 71 70 71 72 70 71 70 71
5078f090 : 70 72 72 71 74 71 72 72 71 73 72 70 71 6f 72 72
5078f0a0 : 72 70 70 71 72 72 6f 70 72 72 74 70 72 72 72 70
5078f0b0 : 75 73 72 6f 71 71 70 73 72 72 72 72 70 72 6e 70
5078f0c0 : 6f 71 71 6e 71 71 6f 71 71 71 70 70 6f 70 6e 70
5078f0d0 : 71 71 6f 70 73 70 6e 70 6f 72 70 6f 73 72 71 70
5078f0e0 : 71 71 70 6f 72 6f 6e 6f 70 6f 73 72 71 70 6f 6f
5078f0f0 : 71 71 70 6f 70 70 6f 70 70 6f 71 6f 71 6e 6f 6f
5078f100 : 6f 70 6f 70 6e 6f 6d 70 72 6f 6f 6e 6e 6d 6e 6e
5078f110 : 6e 6e 6e 6d 71 6f 6d 6f 6e 6e 6f 6e 6e 6d 6e 6e
5078f120 : 6f 6f 6f 6d 71 70 6f 6e 6e 6e 70 6d 6e 6d 6d 6d
5078f130 : 6f 6e 6e 6e 6e 70 71 6e 6f 6e 6f 6d 6d 6d 6d 6d
5078f140 : 6d 6e 6d 70 70 6e 6e 6e 6f 6f 6e 6d 6d 6d 6e 6e
5078f150 : 6d 6e 6c 6b 70 6b 6a 6b 6b 6d 6d 6d 6b 6e 6b
5078f160 : 6d 6d 6c 6c 6e 6b 6d 6b 6b 6c 6f 6c 6d 6c 6c 6c
5078f170 : 6e 6c 6c 6b 6c 6c 6d 6a 6c 6c 6c 6b 6c 6e 6b 6e
5078f180 : 6a 6c 6c 6b 6d 6b 6c 6b 6b 6d 6a 6c 6a 6c 6a 6b
5078f190 : 6d 6b 6c 6b 71 6d 6b 6a 6b 6e 6e 6c 6b 6c 6b 6b
5078f1a0 : 69 6c 6c 6a 6c 6a 6a 6b 6a 6b 6c 6b 6b 6b 6b 6b
5078f1b0 : 6b 6b 6b 6a 6b 6a 6c 6a 6c 6a 69 6b 6a 69 6a 6a 6a
5078f1c0 : 6a 6b 6a 6a 6c 6a 6a 6a 6b 6b 6b 6b 6b 6b 6b 6b
5078f1d0 : 69 6c 6b 69 6d 6a 6b 6b 68 69 6b 69 69 67 69 69
5078f1e0 : 6a 69 69 6a 6c 6a 68 68 6c 69 6c 69 6a 68 69 69
5078f1f0 : 69 69 69 68 69 6a 6a 67 6c 68 69 69 69 69 69 68
5078f200 : 69 66 67 68 6a 68 67 68 69 6a 68 68 68 68 68 68
5078f210 : 67 69 68 67 67 67 67 68 67 67 67 67 67 67 67 67
5078f220 : 67 67 67 65 68 66 66 68 67 67 68 66 67 67 67 67
5078f230 : 69 67 67 67 68 68 66 67 66 66 68 66 66 67 66 66
5078f240 : 67 68 66 66 69 67 67 67 67 67 67 67 67 67 67 67
5078f250 : 67 65 67 65 69 68 67 66 66 66 66 67 67 66 66 66
5078f260 : 68 66 65 65 66 68 66 64 65 67 69 65 65 65 65 65
5078f270 : 66 66 65 63 65 63 65 65 66 64 64 65 65 65 65 65
5078f280 : 67 64 66 63 64 63 64 64 64 64 65 65 63 66 65 65
5078f290 : 66 64 65 65 67 64 64 64 63 64 65 62 69 62 63 63
5078f2a0 : 64 63 62 63 63 64 64 63 65 61 65 64 62 63 63
5078f2b0 : 62 64 62 61 63 62 64 63 63 63 64 62 63 62 63 63
5078f2c0 : 62 63 62 62 62 63 62 63 62 63 62 63 62 63 62 63
5078f2d0 : 62 63 62 6f 65 62 62 62 62 63 64 62 62 63 62
5078f2e0 : 62 61 61 61 62 64 62 61 61 61 62 65 61 62 61 60
5078f2f0 : 6f 61 61 61 62 60 61 61 61 63 62 61 60 61 60
5078f300 : 60 61 61 60 6f 62 60 6f 61 6f 62 6f 61 6f 61 60
5078f310 : 6f 61 60 6f 63 6f 60 6f 60 6f 60 6f 60 6f 60 60
5078f320 : 60 6f 6e 6e 61 60 6e 6f 6f 6f 6f 6f 6f 6f 6f 6f

h) i) j)

Scanning Compensation Data List

5.3.2A Movement of CCD Unit to the Transport Position

■ Function

This procedure moves the CCD unit to the transport position of the right end of its travel. After completing repairs and operation checks on the machine, you need to carry out this procedure immediately before packing and transporting the machine.

NOTE: If an end user needs to transport his/her machine to the dealer or service station for repair, then you should instruct him/her to carry out this procedure if possible before packing and transporting the machine. (For the user-access to the maintenance mode, refer to page 5-3.)

■ Operating Procedure

- (1) Press the **0** and **6** keys in this order in the initial stage of the maintenance mode.

The CCD unit will move to the right end of its travel, during which the "MAINTENANCE 0" will appear on the LCD.

When the CCD unit reaches the transport position, the "SCAN LOCKED" will appear on the LCD.

- (2) Press the **Stop** key to make the machine return to the initial stage of the maintenance mode.

5.3.3 ADF Performance Test

■ Function

The machine counts the documents fed by the automatic document feeder (ADF) and displays the count on the LCD for checking the ADF performance.

■ Operating Procedure

- (1) Set documents. (Allowable up to the ADF capacity.)

The "DOC. READY" will appear on the LCD.

- (2) Press the **0** and **8** keys in this order.

While counting the documents, the machine feeds them in and out, displaying the current count on the LCD as shown below.

ADF CHECK P.01

↑ Current count (1st page in this example)

- (3) After showing the final count, the machine beeps for one second. To return the machine to the initial stage of the maintenance mode, press the **Stop** key.

5.3.4 Test Pattern 1

■ Function

This function, much like the copying function, prints out test pattern 1 to allow the service personnel to check for record data missing or print quality.

■ Operating Procedure

Press the **0** and **9** keys in this order in the initial stage of the maintenance mode.

The figure below shows test pattern 1.

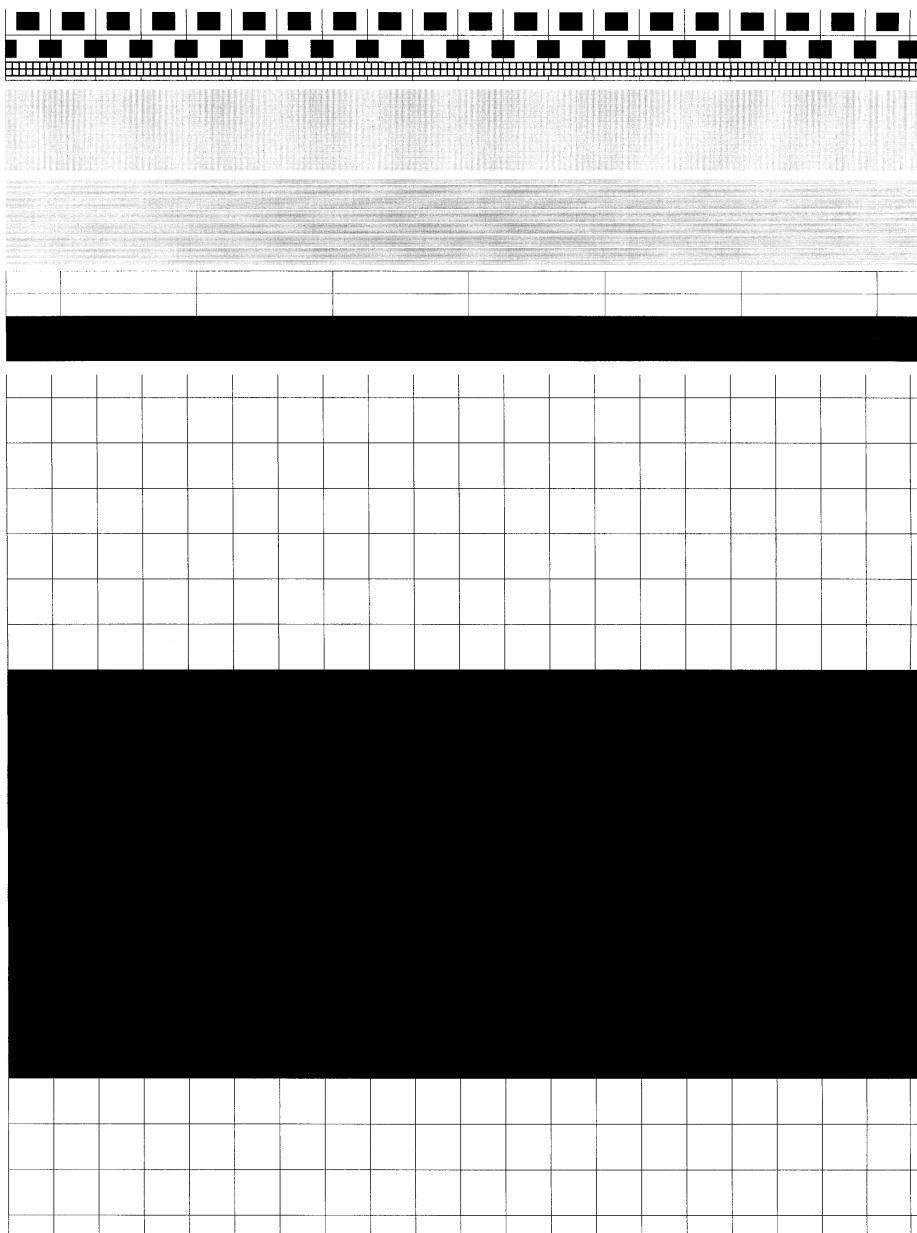

Test Pattern 1

5.3.5 Firmware Switch Setting and Printout

[A] Firmware switch setting

■ Function

The machine incorporates the following firmware switch functions which may be activated with the procedures using the control panel keys and buttons.

The firmware switches have been set at the factory in conformity to the communications standards and codes of each country. Do not disturb them unless necessary. Some firmware switches may not be applicable in some versions. The firmware switch data list indicates "Not used." for those inapplicable switches.

Firmware Switches (WSW01 through WSW46)

WSW No.	Function
WSW01	Dial pulse setting
WSW02	Tone signal setting
WSW03	PABX mode setting
WSW04	TRANSFER facility setting
WSW05	1st dial tone and busy tone detection
WSW06	Pause key setting and 2nd dial tone detection
WSW07	Dial tone setting 1
WSW08	Dial tone setting 2
WSW09	Protocol definition 1
WSW10	Protocol definition 2
WSW11	Busy tone setting
WSW12	Signal detection condition setting
WSW13	Modem setting
WSW14	AUTO ANS facility setting
WSW15	REDIAL facility setting
WSW16	Function setting 1
WSW17	Function setting 2
WSW18	Function setting 3
WSW19	Transmission speed setting in V. 17 mode
WSW20	Overseas communications mode setting
WSW21	TAD setting 1
WSW22	ECM setting
WSW23	Communications setting
WSW24	TAD setting 2
WSW25	TAD setting 3
WSW26	Function setting 4
WSW27	Function setting 5
WSW28	Function setting 6
WSW29	Function setting 7
WSW30	Function setting 8
WSW31	Function setting 9
WSW32	Function setting 10
WSW33	Function setting 11

Firmware Switches (WSW01 through WSW46) *Continued*

WSW No.	Function
WSW34	Function setting 12
WSW35	Function setting 13
WSW36	Function setting 14
WSW37	Function setting 15
WSW38	Function setting 16 in V. 34 mode
WSW39	Transmission speed setting in V. 34 mode
WSW40	Function setting 17 in V. 34 mode
WSW41	CCD fluorescent lamp and modem attenuator in V. 34 mode
WSW42	Function setting 18
WSW43	Function setting 19
WSW44	Speeding up scanning-1
WSW45	Speeding up scanning-2
WSW46	Monitor of power ON/OFF state

■ Operating Procedure

- (1) Press the **1** and **0** keys in this order in the initial stage of the maintenance mode.

The machine displays the "WSW00" on the LCD and becomes ready to accept a firmware switch number.

- (2) Enter the desired number from the firmware switch numbers (01 through 46).

The following appears on the LCD:

Selector 1
Selector 8
↓
↓
 WSWXX = 0 0 0 0 0 0 0

- (3) Use the right and left arrow keys to move the cursor to the selector position to be modified.
- (4) Enter the desired number using the **0** and **1** keys.
- (5) Press the **Set** key. This operation saves the newly entered selector values onto the EEPROM and readies the machine for accepting a firmware switch number.
- (6) Repeat steps (2) through (5) until the modification for the desired firmware switches is completed.
- (7) Press the **Set** or **Stop** key to return the machine to the initial stage of the maintenance mode.

NOTES:

- To cancel this operation and return the machine to the initial stage of the maintenance mode during the above procedure, press the **Stop** key.
- If there is a pause of more than one minute after a single-digit number is entered for double-digit firmware switch numbers, the machine will automatically return to the initial stage of the maintenance mode.

■ Details of Firmware Switches

The details of the firmware switches are described in Appendix 2 in which the user-accessible selectors of the firmware switches are shaded.

[B] Printout of firmware switch data

■ Function

The machine prints out the setting items and contents specified by the firmware switches.

■ Operating Procedure

- (1) Press the **1** key twice in the initial stage of the maintenance mode.
The "PRINTING" will appear on the LCD.
- (2) The machine prints out the configuration list as shown in the figure below.
- (3) Upon completion of printing, the machine returns to the initial stage of the maintenance mode.

CONFIGURATION LIST

MODEL : 8C5-613
TIME : 03/11/1999 09:29
REV. : U0107031847VER.0
PCI : 5.00
SUM : 6959
SER.# : BR0100000028

```
WSW01 = 00000010  
WSW02 = 11111010  
WSW03 = 10000000  
WSW04 = 00010111  
WSW05 = 00000110  
WSW06 = 00101100  
WSW07 = 01001100  
WSW08 = 01100100  
WSW09 = 00000000  
WSW10 = 00010100  
WSW11 = 01011000  
WSW12 = 10011011  
WSW13 = 00011010  
WSW14 = 01100111  
WSW15 = 00001110  
WSW16 = 01100010  
WSW17 = 00100011  
WSW18 = 10001010  
WSW19 = 11100000  
WSW20 = 10011111  
WSW21 = 00101000  
WSW22 = 00100000  
WSW23 = 00001110  
WSW24 = 01000010  
WSW25 = 00011010  
WSW26 = 00110010  
WSW27 = 00100001  
WSW28 = 00000000  
WSW29 = 01101001  
WSW30 = 10000000  
WSW31 = 10100101  
WSW32 = 01010000  
WSW33 = 10000010  
WSW34 = 00010000  
WSW35 = 01000000  
WSW36 = 00001000  
WSW37 = 10000101  
WSW38 = 00010100  
WSW39 = 11110000  
WSW40 = 00000000  
WSW41 = 00000111  
WSW42 = 11110100  
WSW43 = 00000001  
WSW44 = 00000010  
WSW45 = 00000010  
WSW46 = 00000000  
WSW47 = 00000000  
WSW48 = 00000000  
WSW49 = 00000000  
WSW50 = 00000000
```

Configuration List

5.3.6 Operational Check of LCD

■ Function

This function allows you to check whether the LCD on the control panel works normally.

■ Operating Procedure

- (1) Press the **1** and **2** keys in this order in the initial stage of the maintenance mode.

The LCD shows the screen given at right.

- (2) For machines w/ fax: Press the **Fax Start** key. Each time you press the **Fax Start** key, the LCD cycles through the displays shown at right.

For machines w/o fax: Press the **Sort** key. Each time you press the **Sort** key, the LCD cycles through the displays shown at right.

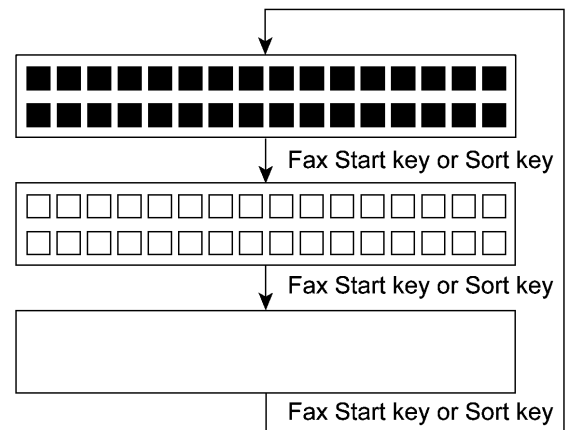

- (3) Press the **Stop** key in any process of the above display cycle. The machine beeps for one second and returns to the initial stage of the maintenance mode.

5.3.7 Operational Check of Control Panel PCB

■ Function

This function allows you to check the control panel PCB for normal operation.

■ Operating Procedure

- (1) Press the **1** and **3** keys in this order in the initial stage of the maintenance mode.

The "00 " will appear on the LCD.

- (2) Press the keys and buttons in the order designated in the illustration shown below.

The LCD shows the corresponding number in decimal notation each time a key or button is pressed. Check that the displayed number is correct by referring to the illustration below.

If a key or button is pressed out of order, the machine beeps and displays the "INVALID OPERATE" on the LCD. To return to the status ready to accept key & button entry for operational check, press the **Stop** key.

- (3) After the last number key or button is pressed, the machine beeps and returns to the initial stage of the maintenance mode.

To terminate this operation, press the **Stop** key. The machine returns to the initial stage of the maintenance mode.

For machines w/ fax

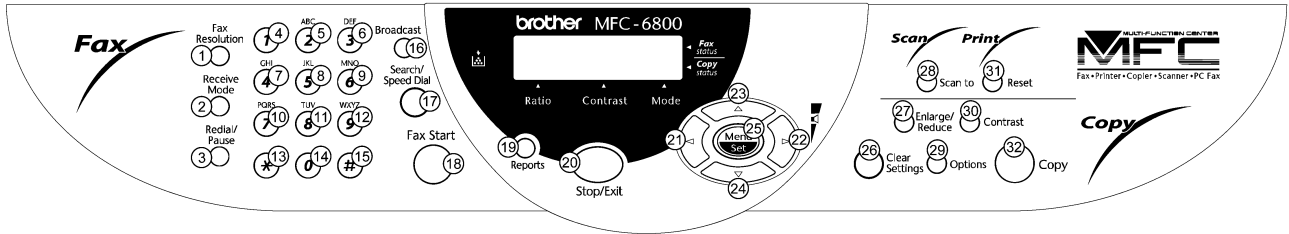

For machines w/o fax

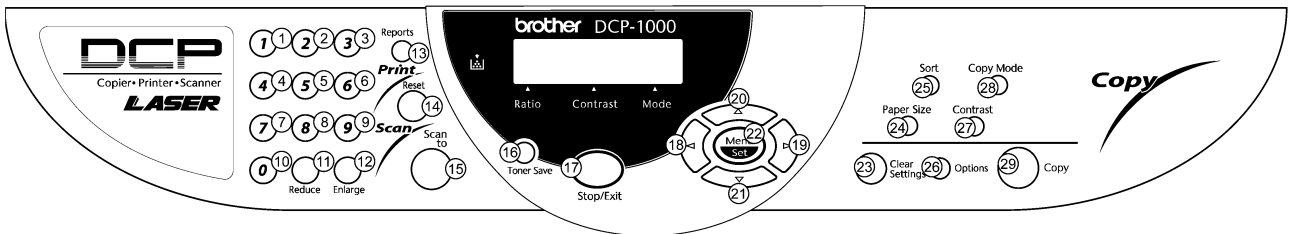

Key & Button Entry Order

5.3.8 Sensor Operational Check

■ Function

This function allows you to check whether the eight sensors--document front sensor, document rear sensor, scanner open sensor, registration sensor, paper ejection sensor, toner sensor, CCD HP sensor, and document tray open sensor--operate correctly.

■ Operating Procedure

- (1) Press the **3** and **2** keys in this order in the initial stage of the maintenance mode. The machine beeps 1100 Hz and 400 Hz tones cyclically through the following volumes for testing the speaker.

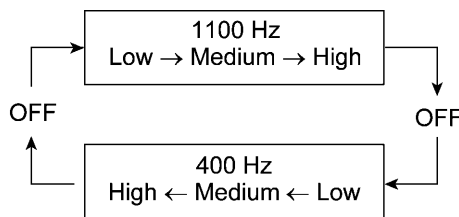

NOTE: To stop beeping, press the **Menu** key.

If the sensing status are as listed below, the LCD will show the following:

"FRRECVRGPOTNFHFC"

Given below is the relationship between the LCD indication, sensor names and sensor status.

LCD	Sensors	Sensing status
FR	Document front sensor	No document detected.
RE	Document rear sensor	No document detected.
CV	Scanner open sensor	Scanner unit closed.
RG	Registration sensor	No paper detected.
PO	Paper ejection sensor	No paper jam.
TN	Toner sensor	Toner detected.
FH	CCD HP sensor	CCD unit placed in the home position
FC	Document tray open sensor	Document tray closed.

- (2) Change the detecting conditions (e.g., insert paper through the document sensors or the registration sensor, open the scanner unit, jam paper at the paper outlet, remove the toner cartridge, move the CCD unit out of the home position, open the document tray), and then check that the indication on the LCD changes according to the sensor states.
- (3) To stop this operation and return the machine to the initial stage of the maintenance mode, press the **Stop** key.

5.3.9 Fine Adjustment of Scanning Start/End Position

■ Function

This function allows you to adjust the scanning start/end position.

■ Operating Procedure

- (1) Press the **5** and **4** keys in this order in the initial stage of the maintenance mode.
The "SCAN START ADJ." and "1.ADF 2.FB" appear on the LCD in this order.
- (2) Press the **1** or **2** key.
The current scanning position correction value appears.
You may adjust the correction value to 11 levels from +5 to -5 (mm).
- (3) To increase the correction value, press the left arrow key; to decrease it, press the right arrow key.
If you press the **Stop** key, the machine returns to the initial stage of the maintenance mode without making change of the correction value.
- (3) Press the **Set** key.
The "ACCEPTED" appears on the LCD. After one second, the machine returns to the initial stage of the maintenance mode.

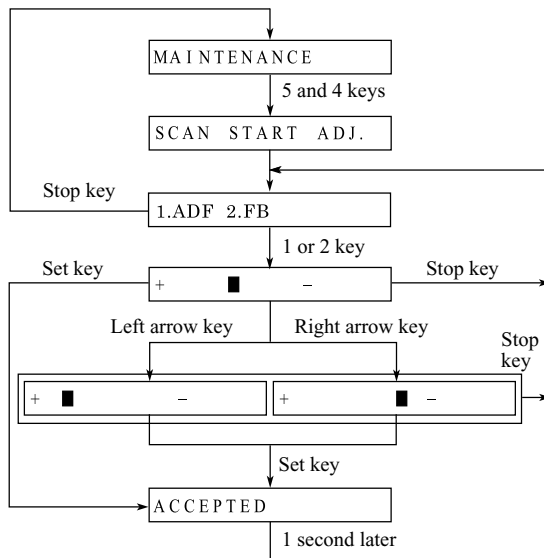

NOTE: The relationship between the scanning start/end positions and their correction values is shown below.

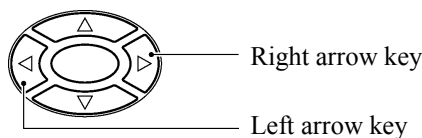
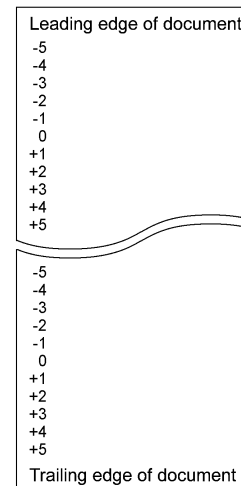

5.3.10 CCD Scanner Area Setting

■ Function

The machine sets the CCD scanner area and stores it into the EEPROM.

■ Operating Procedure

- (1) Press the **5** key twice in the initial stage of the maintenance mode.

The "SCANNER AREA SET" will appear on the LCD.

The machine checks and sets the area to be scanned.

If no error is noted, the machine returns to the initial stage of the maintenance mode.

If any error is noted, the "SCANNER ERROR" will appear on the LCD. To return the machine to the initial stage of the maintenance mode, press the **Stop** key.

5.3.11 EEPROM Customizing

■ Function

This function allows you to customize the EEPROM according to language, function settings, and firmware switch settings. The customizing codes list is given in Appendix 1.

NOTE: If you replace the main PCB, be sure to carry out this procedure.

■ Operating Procedure

- (1) Press the **7** and **4** keys in this order in the initial stage of the maintenance mode.

The current customizing code (e.g., 9001 in the case of MFC6800 USA version) appears.

- (2) Enter the desired customizing code (e.g., 0002 in the case of MFC6800 Canadian version).

The newly entered code appears.

NOTE: *If a wrong 4-digit code is entered, the machine will malfunction.*

- (3) For machines w/ fax: Press the **Fax Start** key.

For machines w/o fax: Press the **Sort** key.

The machine saves the setting and returns to the initial stage of the maintenance mode.

If you press the **Stop** key or no keys are pressed for one minute in the above procedure, the machine stops the procedure and returns to the initial stage of the maintenance mode.

5.3.12 Display of the Machine's Log Information

■ Function

The machine may display the its log information on the LCD.

■ Operating Procedure

- (1) Press the **8** and **0** keys in this order in the initial stage of the maintenance mode.

The USB serial number appears on the LCD.

- (2) For machines w/ fax: Press the **Fax Start** key.
For machines w/o fax: Press the **Sort** key.

Each time the **Fax Start** or **Sort** key is pressed, one of the following log information items appears on the LCD in the order given below.

- 1) Jam count, indicating how many times a paper jam has been occurred
 - 2) Page count, indicating how many pages the current drum has been printed
 - 3) Total page count, indicating how many pages the machine has been printed since produced
 - 4) Drum count, indicating how many times the drum has been rotated
 - 5) Drum change count, indicating how many times drum replacement has been made
 - 6) Toner change count, indicating how many times toner replacement has been made
 - 7) Copy page count, indicating how many copies have been made
 - 8) PC print page count, indicating how many pages the machine has been printed as an output device of the connected PC
 - 9) FAX page count, indicating how many received FAX pages have been printed
 - 10) Error code of the most recent machine error
 - 11) Error code of the most recent communications error
 - 12) ADF jam count, indicating how many times a document jam has been occurred
 - 13) ADF page count, indicating how many documents have been fed
- (3) To stop this operation and return to the machine to the initial stage of the maintenance mode, press the **Stop** key.

5.3.13 Machine Error Code Indication

■ Function

This function displays an error code of the last error on the LCD.

■ Operating Procedure

- (1) Press the **8** and **2** keys in this order in the initial stage of the maintenance mode.
The LCD shows the "MACHINE ERROR X X."
- (2) To stop this operation and return the machine to the initial stage of the maintenance mode, press the **Stop** key.

5.3.14 Output of Transmission Log to the Telephone Line (Not applicable to machines w/o fax)

■ Function

This function outputs the transmission log (that the machine has stored about the latest transmission) to the telephone line. It allows the service personnel to receive the transmission log of the user's machine at a remote location and use it for analyzing problems arising in the user's machine.

■ Operating Procedure

- (1) If the user's machine has a transmission-related problem, call the user's machine at a remote location from your machine.
- (2) If the line is connected, have the user perform the following:
 - 1) For MFC6800 Press the **Menu**, **Receive Mode**, and **0** keys in this order.
For MFC9180 Press the **Menu**, **Fax Resolution**, and **0** keys in this order.
 - 2) Press the **8** and **7** keys.
The above operation makes the user's machine send CNG to your machine for sending the transmission log.
- (3) If you hear the CNG sent from the user's machine, press the **Fax Start** key of your machine.
Your machine will start to receive the transmission log from the user's machine.

5.3.15 Cancellation of the Memory Security Mode (Applicable to the European version w/ fax only)

■ Function

This procedure can cancel the memory security mode. Use this procedure if the user forgets his/her password entered when setting the memory security mode so as not to exit from the memory security mode.

NOTE: Carrying out this procedure will lose passwords previously entered but retain FAX messages received in the memory security mode.

■ Operating Procedure

- (1) When the SECURE MODE is displayed on the LCD, press the **Menu** and **#** keys *at the same time*. Within two seconds, start to press the **2**, **7**, **9**, **0**, and **0** keys.

The memory security mode will be canceled and the machine returns to the calendar clock screen.

CHAPTER 6

ERROR INDICATION AND TROUBLESHOOTING

CHAPTER 6 ERROR INDICATION AND TROUBLESHOOTING

CONTENTS

6.1	ERROR INDICATION.....	6-1
6.1.1	Machine Errors	6-1
[1]	Error messages on the LCD	6-1
[2]	Error codes shown in the "MACHINE ERROR X X " message.....	6-5
6.1.2	Communications Errors.....	6-7
6.2	TROUBLESHOOTING.....	6-17
6.2.1	Introduction.....	6-17
6.2.2	Precautions	6-17
6.2.3	Checking prior to Troubleshooting	6-17
6.2.4	Troubleshooting Procedures	6-19
[1]	Control panel related.....	6-19
[2]	Telephone related	6-19
[3]	Communications related	6-20
[4]	Paper/document feeding related	6-20
[5]	Print-image related.....	6-21
	<u>Location of High-voltage Contacts and Grounding Contacts</u>	<u>6-28</u>

6.1 ERROR INDICATION

To help the user or the service personnel promptly locate the cause of a problem (if any), the machine incorporates the self-diagnostic functions which display error messages for machine errors and communications errors.

For the communications errors, the machine also prints out the transmission verification report and the communications list.

6.1.1 Machine Errors

If a machine error occurs, the machine emits an audible alarm (continuous beeping) for approximately 4 seconds and shows the error message on the LCD. For the error messages, see [1] below.

To display detailed error information, use the maintenance-mode function code 82 described in CHAPTER 5, Subsection 5.3.13 (that is, make the machine enter the maintenance mode and then press the **8** and **2** keys). Following the MACHINE ERROR, one of the error codes listed in [2] will appear on the LCD.

[1] Error messages on the LCD

Messages on the LCD	Probable Cause
CHANGE DRUM SOON	The service life of the drum unit will expire soon. This message appears for one minute. (You can turn this message indication on or off by the maintenance-mode function code 10, WSW31, selector 8. Refer to Appendix 2.)
CHECK ORIGINAL Remove original, and then press STOP KEY. (See NOTE below.) or CHECK DOCUMENT Remove document, then press STOP KEY.	<ul style="list-style-type: none"> ■ Document jam (1) The document length exceeds the limitation (400 or 90 cm) registered by firmware switch WSW16. (Refer to Appendix 2.) (Both the document front and rear sensors stay ON after the document has been fed by the registered length.) (2) The document rear sensor detects no trailing edge of a document after the document has been fed by 400 cm. (The document rear sensor stays ON even after the document has been fed when the document front and rear sensors were OFF and ON, respectively.)

NOTE: This message appears in North American models.

Messages on the LCD	Probable Cause
<p>CHECK ORIGINAL Remove original, and then press STOP KEY. (See NOTE below.) or CHECK DOCUMENT Remove document, then press STOP KEY.</p>	<p>■ Document loading error</p> <p>(1) The document rear sensor detects no leading edge of a document within 10 seconds from the start of document loading operation. (The document rear sensor stays OFF even after the document has been fed when the document front sensor was ON.)</p> <p>(2) The loaded document is too short. (Since the document is shorter than the distance between the document front and rear sensors, the document front sensor is turned OFF before the document rear sensor is turned ON.)</p>
<p>CHECK DRUM UNIT Open cover, then reinstall drum unit.</p>	<p>No drum unit is loaded.</p>
<p>CHECK PAPER Reload paper by using lever, then press FAX START.</p>	<p>Even after paper pick-up operation, the registration sensor does not detect paper.</p>
<p>CHECK PAPER Reload paper by using lever, then press COPY. (These messages apply to models w/o fax.)</p>	
<p>CHECK PAPER SIZE Reload correct paper, then press FAX START.</p>	<p>The registration sensor detects that paper shorter than the specified length has been fed. (This message appears only when a received message is printed.)</p>
<p>CHECK PAPER SIZE Reload correct paper, then press COPY. (These messages apply to models w/o fax.)</p>	
<p>CLEAN UP SCANNER</p>	<p>In the scanning compensation data list printed by the maintenance-mode function code 05, less than fifty percent of the white level data is faulty. (This message may appear only in the maintenance mode.)</p>

NOTE: This message appears in North American models.

Messages on the LCD	Probable Cause
COOLING DOWN WAIT FOR A WHILE	<p>The controller, which monitors the internal resistance of toner thermistor, has detected that the toner temperature exceeded the specified level. If temperature exceeds the preset level, recording is no longer possible.</p> <p>If the toner temperature drops, the machine will be automatically recovered from the error state.</p>
COVER OPEN PLS CLOSE COVER	<p>The scanner open sensor detects that the scanner unit is not closed.</p>
DOC. COVER OPEN Remove original and close cover.	<p>The document tray open sensor detects that the document tray is not closed when the ADF is feeding or ejecting a document(s).</p>
MACHINE ERROR XX Unplug machine, then call Brother.	<p>"XX" indicates an error code. Refer to [2] on the following pages.</p>
PAPER JAM Open cover, then remove jammed paper.	<p>Paper jam</p> <ol style="list-style-type: none"> (1) The registration sensor detects no paper within the specified time length after the start of paper pulling-in. (2) The registration sensor has been ON for less than the specified time length (paper of approx. 3.15" long) or for more than the specified time length (paper of approx. 16" long). (3) When the machine is switched on or the scanner unit is opened and then closed, the registration sensor or paper ejection sensor is ON. (4) The paper ejection sensor sticks to ON. (5) The paper ejection sensor does not come ON within the specified time length after the registration sensor has come ON. (6) The paper ejection sensor is kept ON after the specified time length although the registration sensor has come ON.
PLS OPEN COVER	<p>To display the relating detailed error code, use maintenance-mode function code 82. (Refer to CHAPTER 5, Subsection 5.3.13.)</p> <p>If this message appears, open and close the scanner unit. The message may disappear if opening/closing the scanner unit removes the error. If the error persists, the "MACHINE ERROR XX" will appear.</p>

Messages on the LCD	Probable Cause
SCANNER ERROR	In the scanning compensation data list printed by the maintenance-mode function code 05, fifty percent or more of the white level data is faulty. (This message may appear only in the maintenance mode.)
TONER EMPTY Open cover, then replace new toner cartridge.	The toner sensor has detected that there is no toner in the cartridge or that no toner cartridge is loaded. If this message appears, recording is no longer possible.
TONER LOW	The toner sensor has detected that there is not enough toner.
WARMING UP WAIT FOR A WHILE	The in-casing temperature is too low. If the temperature reaches the appropriate level, the machine will be automatically recovered from the error state.

If only an alarm beep is heard without any message on the LCD when the machine is turned on, the ROM or RAM will be defective.

[2] Error codes shown in the "MACHINE ERROR X X" message

Error Code <u>X X</u> (Hex.)	Error factor
(71	Polygon motor does not synchronize with the reference clock.)
(72	Cannot detect Beam Detect signal.)
(73	No toner cartridge loaded.)
(74	Toner empty.)
(75	In-casing temperature error.)
(76	Heater harness disconnected or broken. Or heater thermistor harness disconnected or broken when the power is turned on, the top cover is opened and closed, or the machine exits from the sleep mode.)
(77	Power turned off and on at the occurrence of error 76 or 78.)
(78	Heater thermistor short-circuited. Or heater thermistor harness disconnected or broken when the machine is on standby.)
(79	Toner thermistor harness disconnected or broken.)
(80	Paper size setting error.)
(82	Paper feeding error.)
(83	Paper jam. The registration sensor remains ON.)
(84	Paper jam. The paper ejection sensor remains ON.)
(88	Paper jam. Even after the registration sensor has gone OFF, the paper ejection sensor still stays OFF.)
(A1	Scanner unit opened.)
(A2	Document too long to scan.)
(A3	Document not detected by the document rear sensor.)
(A4	50% or more faulty of white level data.)
(A7	One-line feeding timeout error.)
(A8	One-line scanning timeout error.)
(A9	Abnormal scanning reference voltage.)
(AA	Document tray opened.)
(AC	Less than 50% faulty of white level data.)

Error codes in parentheses do not appear in the "MACHINE ERROR X X", since those errors are displayed as messages described in "[1] Error messages on the LCD." In the maintenance mode (Function code 82), those error codes may be displayed.

Error Code <u>X X</u> (Hex.)	Error factor
(AE	The CCD HP sensor sticks to OFF, indicating that the CCD unit has not returned to the home position.)
(AF	The CCD HP sensor sticks to ON, indicating that the CCD unit has stayed in the home position.)
(B1	Dark level offset data error.)
(B2	Gain control data error.)
(B3	Scan area left edge detection error.)
(B4	Scan area right edge detection error.)
(B7	A/D converter reference voltage error (at High level).)
(B8	A/D converter reference voltage error (at Low level).)
(BA	Magnification error for substantial white level data.)
(BB	Substantial white level data error in black & white mode.)
(BC	Substantial white level data error in photo mode.)
(BD	Black level data error.)
(BE	Detection error of black mark.)
(BF	Detection error of ADF scanning position.)
(D5	The MODEM fails to complete the command transmission sequence.)
(E4	Out of recording paper.)
E6	Write error in EEPROM.
(E8	Data scanning error during transmission.)
(EA	Document removed in phase B.)
(F5	EOL not found in page memory transmission mode.)
(F6	PC interface error.)

Error codes in parentheses do not appear in the "MACHINE ERROR X X", since those errors are displayed as messages described in "[1] Error messages on the LCD." In the maintenance mode (Function code 82), those error codes may be displayed.

6.1.2 Communications Errors

If a communications error occurs, the machine

- ① emits an audible alarm (intermittent beeping) for approximately 4 seconds,
- ② displays the corresponding error message, and
- ③ prints out the transmission verification report if the machine is in sending operation.

■ Definition of Error Codes on the Communications List

(1) Calling

Code 1	Code 2	Causes
10	08	Wrong number called.
10	20	Retrieval file error.
10	21	Image data entry error.
11	01	No dial tone detected before start of dialing.
11	02	Busy tone detected before dialing.
11	03	2nd dial tone not detected.
11	05	No loop current detected.*
11	06	Busy tone detected after dialing or called.
11	07	No response from the remote station in sending.
11	10	No tone detected after dialing.
17	07	No response from the calling station in receiving.
1A	01	Calling impossible due to memory full.

*Available in German versions only.

(2) Command reception

Code 1	Code 2	Causes
20	01	Unable to detect a flag field.
20	02	Carrier was OFF for 200 ms or longer.
20	03	Abort detected ("1" in succession for 7 bits or more).
20	04	Overrun detected.
20	05	A frame for 3 seconds or more received.
20	06	CRC error in answerback.
20	07	Undefined command received.
20	08	Invalid command received.
20	09	Command ignored once for document setting or for dumping-out at turn-around transmission.
20	0A	T5 timeout error
20	0B	CRP received.

Code 1	Code 2	Causes
20	0C	EOR and NULL received.
20	0D	Effective command not received.
20	10	Unable to reserve a command receiver memory.
20	11	Image data file error.

(3) Compatibility [checking the NSF and DIS]

Code 1	Code 2	Causes
32	01	Remote terminal only with V.29 capability in 2400 or 4800 bps transmission.
32	02	Remote terminal not ready for polling.
32	10	Remote terminal not equipped with password function or its password switch OFF.
32	11	Remote terminal not equipped with or not ready for confidential mail box function.
32	12	Remote terminal not equipped with or not ready for relay broadcasting function.
32	13	No confidential mail in the remote terminal.
32	14	The available memory space of the remote terminal is less than that required for reception of the confidential or relay broadcasting instruction.

(4) Instructions received from the remote terminal [checking the NSC, DTC, NSS, and DCS]

Code 1	Code 2	Causes
40	02	Illegal coding system requested.
40	03	Illegal recording width requested.
40	05	ECM requested although not allowed.
40	06	Polled while not ready.
40	07	No document to send when polled.
40	10	Nation code or manufacturer code not coincident.
40	11	Unregistered group code entered for relay broadcasting function, or the specified number of broadcasting subscribers exceeding the limit.
40	12	Retrieval attempted when not ready for retrieval.
40	13	Polled by any other manufacturers' terminal while waiting for secure polling.
40	17	Invalid resolution selected.

(5) Command reception [checking the NSF and DIS after transmission of NSS and DCS]

Code 1	Code 2	Causes
50	01	Vertical resolution capability changed after compensation of background color.

(6) ID checking

Code 1	Code 2	Causes
63	01	Password plus "lower 4 digits of telephone number" not coincident.
63	02	Password not coincident.
63	03	Polling ID not coincident.
63	04	Entered confidential mail box ID uncoincident with the mail box ID.
63	05	Relay broadcasting ID not coincident.
63	06	Entered retrieval ID uncoincident with that of the mail box ID.

(7) DCN reception

Code 1	Code 2	Causes
74		DCN received.

(8) TCF transmission/reception

Code 1	Code 2	Causes
80	01	Fallback impossible.

(9) Signal isolation

Code 1	Code 2	Causes
90	01	Unable to detect video signals and commands within 6 seconds after CFR is transmitted.
90	02	Received PPS containing invalid page count or block count.

(10) Video signal reception

Code 1	Code 2	Causes
A0	03	Error correction sequence not terminated even at the final transmission speed for fallback.
A0	11	Receive buffer empty. (5-second time-out)
A0	12	Receive buffer full during operation except receiving into memory.
A0	13	Decoding error continued on 500 lines.
A0	14	Decoding error continued for 10 seconds.
A0	15	Timeout: Five seconds or more for one-line transmission.
A0	16	RTC not found and carrier OFF signal detected for 6 seconds.
A0	17	RTC found but no command detected for 60 seconds.
A0	18	Receive buffer full during receiving into memory.
A0	19	Unable to obtain compressed image data to be sent in phase C.
A8	01	RTN, PIN, or ERR received at the calling terminal.*
A9	01	RTN, PIN, or ERR received at the called terminal.*

* Available in German versions only

(11) General communications-related

Code 1	Code 2	Causes
B0	02	Unable to receive the next-page data.
B0	03	Unable to receive polling even during turn-around transmission due to call reservation.
B0	04	PC interface error.
BF	01	Transmission canceled by pressing the Stop key (before completion of the G3 FAX negotiation).
BF	02	Transmission canceled by pressing the Stop key (after completion of the G3 FAX negotiation).
BF	03	Transmission canceled due to a scanning error.

(12) Transmission in V. 34 mode

Code 1	Code 2	Causes
C0	01	No common modulation mode or failed to poll.
C0	02	Unable to detect JM.
C0	03	Unable to detect CM.
C0	04	Unable to detect CJ.
C0	10	Cannot finish V. 34 negotiation or training.
C0	11	Modem error detected during V. 34 negotiation or training. (For modem error details, refer to the table given on the next page.)
C0	20	Modem error detected during sending of commands. (For modem error details, refer to the table given on the next page.)
C0	21	Modem error detected during receiving of commands. (For modem error details, refer to the table given on the next page.)
C0	22	Control channel connection time-out.
C0	30	Modem error detected during sending of video signals. (For modem error details, refer to the table given on the next page.)
C0	31	Modem error detected during receiving of video signals. (For modem error details, refer to the table given on the next page.)

Modem error details (Code 3)

Code 3	Causes
21	Timeout waiting for INFO0.
22	Checksum error in INFO0.
23	Timeout waiting for tone A or B.
24	Timeout waiting for first phase reverse.
25	Timeout waiting for probing cut-off tone.
26	Timeout waiting for second phase reverse.
27	Timeout waiting for end of probing.
28	Timeout waiting for third phase reverse.
29	Timeout waiting for INFO1.
2A	Checksum error in INFO1.
2B	Tone detected preceding INFO0.
2C	Unexpected INFO0 detected.
31	Timeout waiting for turning off the receive control channel.
91	Error occurred in the first CC train.
92	Timeout waiting for PPh.
93	Tone A/B detected in the CC retrain.
94	Timeout waiting for ALT.
95	ACh found.
96	FED turned off during reception of CC data.
97	Timeout waiting for turning off the CC.
A1	Retraining forced for problems not fixed in phase 2.
B0	Problem with S-sequence of HDX-resync.
B1	FED turned off in the S-sequence of HDX-resync.
B2	S-sequence finished before prediction in HDX-resync.
B3	Timeout waiting for S-Sbar in HDX-resync.
B4	Timeout waiting for S-Sbar in HDX-resync.
B5	Timeout waiting for S in HDX-resync.
B6	Timeout waiting for synchronization with PP.
C0	Problem with S-sequence in phase 3.
C1	FED turned off in the S-sequence in phase 3.

Code 3	Causes
C2	S-sequence finished before prediction in phase 3.
C3	Timeout waiting for S-Sbar in phase 3.
C4	Timeout waiting for S-Sbar in phase 3.
C5	Timeout waiting for S in phase 3.
C7	Training after TRN failure.
D0	Problem with S-sequence in phase 4.
D1	FED turned off in S-sequence in phase 4.
D2	S-sequence finished before prediction in phase 4.
D3	Timeout waiting for S-Sbar in phase 4.
D4	Timeout waiting for S-Sbar in phase 4.
D5	Timeout waiting for S in phase 4.
D6	Timeout waiting for MP.
D8	Timeout waiting for E.
DA	Timed out in re-negotiation of the transmitter rate.
DB	Timed out in the transmitter MPH.
E2	Retraining detected in phase 2.
E3	Retraining detected in phase 3.
E4	Retraining detected in phase 4.
FE	DTR turned off during retraining.
FF	Tx set-abort flag.
71	Did not write onto the first mapping frame.

(13) Maintenance mode

Code 1	Code 2	Causes
E0	01	Failed to detect 1300 Hz signal in burn-in operation.
E0	02	Failed to detect PB signals in burn-in operation.
E0	03	Failed to detect commands from the RS-232C in burn-in operation.

(14) Machine error

Code 1	Code 2	Causes
FF	00	Burn-in operation canceled by pressing the Stop key.
FF	FF	Unrecoverable MODEM error.

6.2 TROUBLESHOOTING

6.2.1 Introduction

This section gives the service personnel some of the troubleshooting procedures to be followed if an error or malfunction occurs with the machine. It is impossible to anticipate all of the possible problems which may occur in future and determine the troubleshooting procedures, so this section covers some sample problems. However, those samples will help service personnel pinpoint and repair other defective elements if he/she analyzes and examines them well.

6.2.2 Precautions

Be sure to observe the following to prevent the secondary troubles from happening:

- (1) Always unplug the AC power cord from the outlet when removing the covers and PCBs, adjusting the mechanisms, or conducting continuity testing with a circuit tester.
- (2) When disconnecting the connectors, do not pull the lead wires but hold the connector housings.
- (3)
 - Before handling the PCBs, touch a metal portion of the machine to discharge static electricity charged in your body.
 - When repairing the PCBs, handle them with extra care.

After repairing the defective section, be sure to check again if the repaired section works correctly. Also record the troubleshooting procedure so that it would be of use for future trouble occurrence.

6.2.3 Checking prior to Troubleshooting

Prior to proceeding to the troubleshooting procedures given in Subsection 6.2.4, make the following initial checks:

Environmental conditions

Check that:

- (1) The machine is placed on a flat, firm surface.
- (2) The machine is used in a clean environment at or near normal room temperature (10°C to 32.5°C) with normal relative humidity (20 to 80%).
- (3) The machine is not subjected to rapid change of the ambient temperature. (Moving the machine from a cold place to warm place will cause condensation inside the machine. If it takes place, leave the machine in the warm place for approx. two hours before turning on the power.) Powering on the machine with dew condensation will result in damaged electronic devices.
- (4) The machine is not exposed to direct sunlight or harmful gases.

Power requirements

Check that:

- (1) The power supply specified on the rating plate located on the bottom of the machine is used. The supply voltage stays within the rating $\pm 10\%$.
- (2) Each voltage level on AC input lines and DC lines is correct.
- (3) All cables and harnesses are firmly connected.
- (4) None of the fuses are blown.

Recording paper

Check that:

- (1) A recommended type of recording paper is used.
- (2) The recording paper is not dampened.

6.2.4 Troubleshooting Procedures

[1] Control panel related

Trouble	Check:
(1) LCD shows nothing.	<ul style="list-style-type: none"> • Panel harness between the control panel PCB and relay PCB • Relay (CCD/PANEL) harness between the relay PCB and main PCB • Control panel PCB • Low-voltage power supply PCB • Main PCB • LCD
(2) Control panel inoperative.	<ul style="list-style-type: none"> • Panel harness between the control panel PCB and relay PCB • Relay (CCD/PANEL) harness between the relay PCB and main PCB • Control panel PCB • FPC key • Main PCB

[2] Telephone related

Trouble	Check:
(1) No phone call can be made.	<ul style="list-style-type: none"> • FPC key • Control panel PCB • NCU PCB • Main PCB
(2) Speed dialing or one-touch dialing will not work.	<ul style="list-style-type: none"> • Ordinary dialing function (other than the speed and one-touch dialing) <p>If it works normally, check the main PCB; if not, refer to item (1) above.</p>
(3) Speaker silent during on-hook dialing.	<ul style="list-style-type: none"> • Ordinary dialing function (other than the on-hook dialing with the hook key) <p>If it works normally, proceed to the following checks; if not, refer to item (1) above.</p>
(4) Dial does not switch between tone and pulse.	<ul style="list-style-type: none"> • Main PCB • NCU PCB
(5) Telephone does not ring.	<ul style="list-style-type: none"> • Speaker • NCU PCB • Main PCB

[3] Communications related

Trouble	Check:
(1) No tone is transmitted.	<ul style="list-style-type: none">• Main PCB• NCU PCB



[4] Paper/document feeding related

Trouble	Check:
(1) Neither "COPY: PRESS COPY" nor "FAX: NO. & START" message appears although documents are set.	<ul style="list-style-type: none">• Sensors by using the maintenance-mode function code 32. (Refer to CHAPTER 5, Subsection 5.3.8.)• Document front sensor actuator and document rear sensor actuator• Main PCB
(2) Document not fed.	<ul style="list-style-type: none">• ADF and its related sections• ADF motor and its harness• Document feed roller and its related gears• Main PCB
(3) Document double feeding	<ul style="list-style-type: none">• ADF parts
(4) Recording paper not fed.	<ul style="list-style-type: none">• ASF• Drum unit• Heat-fixing unit• Drive gear ASSY• Main PCB
(5) Recording paper double feeding	<ul style="list-style-type: none">• Separation pad on the ASF

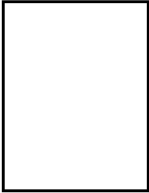

[5] Print-image related

If the received or sent image has any problem, first make a copy with the machine.

If the copied image is normal, the problem may be due to the remote terminal; if it is abnormal, proceed to the following checks:

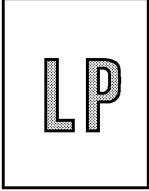
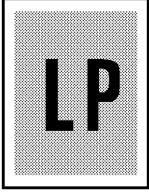
Trouble	Action to be taken
<p>(1) Completely blank</p> 	<p><u>At the scanner</u></p> <p>Check the following components:</p> <ul style="list-style-type: none"> - CCD flat cable - Main PCB - CCD unit <p><u>At the printer side</u></p> <ul style="list-style-type: none"> ● Clean the high-voltage contacts for the developer roller on the drum unit, main cover, and high-voltage power supply PCB. (Contacts ③ in the illustration given on page 6-28) ● Clean the grounding contacts on the drum unit, main cover, and high-voltage power supply PCB. (Contacts ① in the illustration given on page 6-28) ● Check that the grounding plate is sandwiched between the contact plate and gear drive unit. (Refer to CHAPTER 4, Subsection 4.1.21, page 4-52.) ● Replace the toner cartridge. ● Replace the drum unit. ● Check the connection of the laser flat cable on the main PCB. ● Replace the main PCB. ● Replace the laser unit. ● Replace the high-voltage power supply PCB.
<p>(2) All black</p> 	<p><u>At the scanner</u></p> <p>Check the following components:</p> <ul style="list-style-type: none"> - CCD flat cable - CCD unit - Main PCB <p><u>At the printer side</u></p> <ul style="list-style-type: none"> ● Clean the high-voltage contacts for the grid and charger on the drum unit, main cover, and high-voltage power supply PCB. (Contacts ⑤ and ⑥ in the illustration given on page 6-28) ● Clean the charger (corona wires) itself. ● Check the connection of the laser flat cable on the main PCB. ● Replace the drum unit. ● Replace the high-voltage power supply PCB. ● Replace the main PCB.

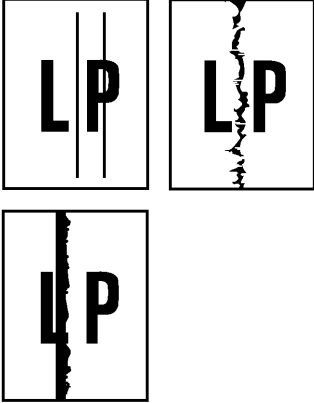
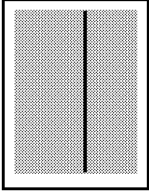
Trouble	Action to be taken
<p>(3) Light</p> 	<p><u>At the scanner</u></p> <p>Check the following components:</p> <ul style="list-style-type: none"> - CCD unit - Main PCB <p><u>At the printer side</u></p> <ul style="list-style-type: none"> ● Replace the toner cartridge with a new one and print 4 to 5 pages. If the problem persists, proceed to the next step. ● Remove the toner cartridge and start printing. If printing takes place, clean the toner sensors (LED and light-receiver), check the sensor harnesses, and then replace the toner sensor PCBs. ● Clean the high-voltage contacts for the transfer roller on the drum unit, main cover, and high-voltage power supply PCB. (Contacts ③ in the illustration given on page 6-28) ● Clean the high-voltage contacts for the developer roller on the drum unit, main cover, and high-voltage power supply PCB. (Contacts ⑦ in the illustration given on page 6-28) ● Clean the grounding contacts on the drum unit, gear drive unit, and main cover. (Contacts ① and ② in the illustration given on page 6-28) ● Check the connection of the high-voltage power flat cable on the main PCB and high-voltage power supply PCB. ● Replace the drum unit. ● Replace the high-voltage power supply PCB. ● Replace the main PCB. ● Replace the laser unit.
<p>(4) Dark</p> 	<p><u>At the scanner</u></p> <p>Check the following components:</p> <ul style="list-style-type: none"> - CCD unit - Main PCB <p><u>At the printer side</u></p> <ul style="list-style-type: none"> ● Slide the wire cleaner to clean the corona wire inside the drum unit. ● Clean the high-voltage contacts for the grid and charger on the drum unit, main cover, and high-voltage power supply PCB. (Contacts ⑤ and ⑥ in the illustration given on page 6-28) ● Replace the toner cartridge. ● Replace the drum unit. ● Replace the high-voltage power supply PCB. ● Replace the main PCB.

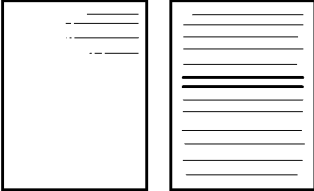
Trouble	Action to be taken
<p>(5) Black and blurred vertical stripes or band</p> 	<p><u>At the scanner</u></p> <p>Check the following components:</p> <ul style="list-style-type: none"> - CCD unit <p><u>At the printer side</u></p> <ul style="list-style-type: none"> • Clean the paper path which may be contaminated with toner. • Slide the wire cleaner to clean the corona wire inside the drum unit. • Make sure that the wire cleaner is returned to its home position. • Replace the toner cartridge. • Replace the drum unit. • Replace the heat-fixing unit.
<p>(6) Black vertical streaks on gray background</p> 	<p><u>At the printer side</u></p> <ul style="list-style-type: none"> • Clean the laser beam window (glass) on the laser unit. • Replace the laser unit.
<p>(7) Black and blurred horizontal stripes</p> 	<p><u>At the printer side</u></p> <ul style="list-style-type: none"> • Slide the wire cleaner to clean the corona wire inside the drum unit. • If they appear at 94-mm or 17-mm intervals, replace the drum unit. • If they appear at 54-mm intervals, replace the heat-fixing unit. • Replace the high-voltage power supply PCB.
<p>(8) Horizontal lines</p> 	<p><u>At the printer side</u></p> <ul style="list-style-type: none"> • Check the connection between the right end of the paper feed roller and the grounding wire. (Contact ⑦ in the illustration given on page 6-28.)

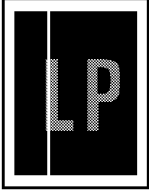
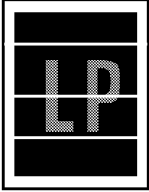
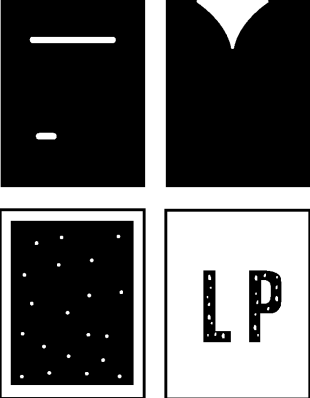
Trouble	Action to be taken
<p>(9) White vertical streaks</p> 	<p><u>At the scanner</u></p> <p>Check the following components:</p> <ul style="list-style-type: none"> - CCD unit <p><u>At the printer side</u></p> <ul style="list-style-type: none"> • Clean the laser beam window on the laser unit. • Replace the toner cartridge. • Replace the drum unit.
<p>(10) White horizontal stripes</p> 	<p><u>At the printer side</u></p> <ul style="list-style-type: none"> • Replace the drum unit.
<p>(11) Dropout, white spots, or hollow print</p> 	<p><u>At the printer side</u></p> <ul style="list-style-type: none"> • Check the connection of the high-voltage power flat cable on the main PCB and high-voltage power supply PCB. • Replace the toner cartridge. • Gently wipe off the surface of the photo-sensitive drum with a cotton swab. • Replace the drum unit. • Replace the high-voltage power supply PCB.

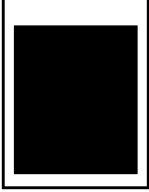
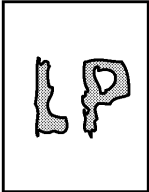
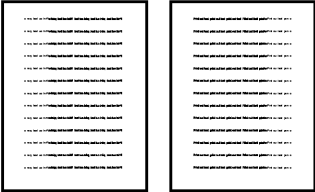
Trouble	Action to be taken
<p>(12) Faulty image registration (Leading edge of image starts too late on paper)</p> 	<p><u>At the printer side</u></p> <ul style="list-style-type: none"> ● Instruct the user not to load paper exceeding the limit in the ASF. ● Instruct the user to use the recommended types of paper. ● Replace the ASF. ● Check the position of the registration sensor. ● Replace the gear drive unit.
<p>(13) Image distortion or improper image alignment</p> 	<p><u>In communications</u></p> <p>Check the following components:</p> <ul style="list-style-type: none"> - Error code displayed. (Refer to Section 6.1, "ERROR INDICATION" in this chapter.) - NCU PCB - Main PCB <p><u>At the scanner</u></p> <p>Check the following components:</p> <ul style="list-style-type: none"> - Document take-in roller, separation roller, and their related sections - Document feed roller and its related gears - ADF motor and its harness - Main PCB <p><u>At the printer side</u></p> <ul style="list-style-type: none"> ● Check that the laser unit is secured with the screws without looseness. ● Check the connection of the polygon motor harness. ● Check the connection of the laser flat cable on the main PCB. ● Replace the laser unit.
<p>(14) Blurred at either side</p> 	<p><u>At the printer side</u></p> <ul style="list-style-type: none"> ● Check that the machine is placed on a flat surface. ● Shake the toner cartridge horizontally. If the problem persists, replace it. ● Clean the laser beam window (glass) on the laser unit. ● Replace the laser unit.

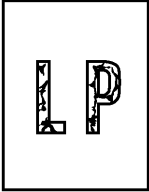
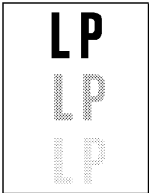
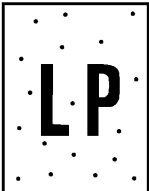
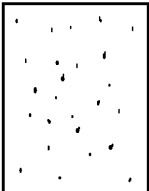
Trouble	Action to be taken
<p>(15) Dirt back of paper</p> 	<p><u>At the printer side</u></p> <ul style="list-style-type: none"> ● Clean the pressure roller in the heat-fixing unit. Replace the heat-fixing unit. ● Replace the drum unit. ● Replace the high-voltage power supply PCB.
<p>(16) Poor fixing</p> 	<p><u>At the printer side</u></p> <ul style="list-style-type: none"> ● Instruct the user to use paper of the recommended weight (less than 36 lb./m²). ● Clean the toner sensors (LED and light-receiver). ● Replace the toner cartridge. ● Replace the drum unit. ● Check the fitting of the heater thermistor. Replace the heat-fixing unit. ● Replace the low-voltage power supply PCB.
<p>(17) Ghost</p> 	<p><u>At the printer side</u></p> <ul style="list-style-type: none"> ● Instruct the user to use paper of the recommended weight (less than 36 lb./m²). ● Replace the drum unit. ● Replace the high-voltage power supply PCB.
<p>(18) Black spots</p> 	<p><u>At the printer side</u></p> <ul style="list-style-type: none"> ● Gently wipe off the surface of the photo-sensitive drum with a cotton swab. ● Replace the drum unit. ● Replace the heat-fixing unit. ● Replace the high-voltage power supply PCB.
<p>(19) Light rain</p> 	<p><u>At the printer side</u></p> <ul style="list-style-type: none"> ● Replace the drum unit. ● Replace the high-voltage power supply PCB.

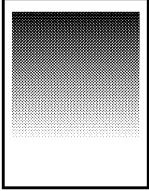
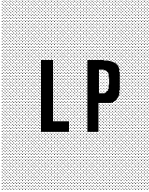
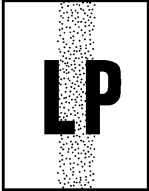
Trouble	Action to be taken
<p>(20) Fading (black to white)</p> 	<p><u>At the printer side</u></p> <ul style="list-style-type: none"> ● Replace the toner cartridge. ● Replace the high-voltage power supply PCB.
<p>(21) Gray background</p> 	<p><u>At the printer side</u></p> <ul style="list-style-type: none"> ● Instruct the user to use paper of the recommended weight (less than 36 lb./m²). ● Clean the toner sensors (LED and light-receiver). ● Check the toner sensor harnesses. ● Replace the toner cartridge. ● Replace the drum unit. ● Replace the high-voltage power supply PCB.
<p>(22) Toner specks</p> 	<p><u>At the printer side</u></p> <ul style="list-style-type: none"> ● Instruct the user to use paper of the recommended weight (less than 36 lb./m²). ● Replace the toner cartridge. ● Replace the drum unit.

Location of High-voltage Contacts and Grounding Contacts

Grounding Contacts

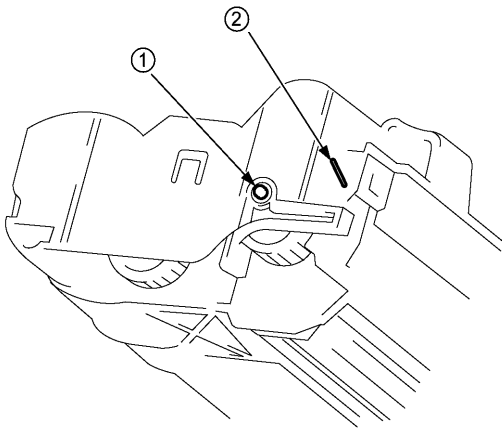

High-voltage Contacts

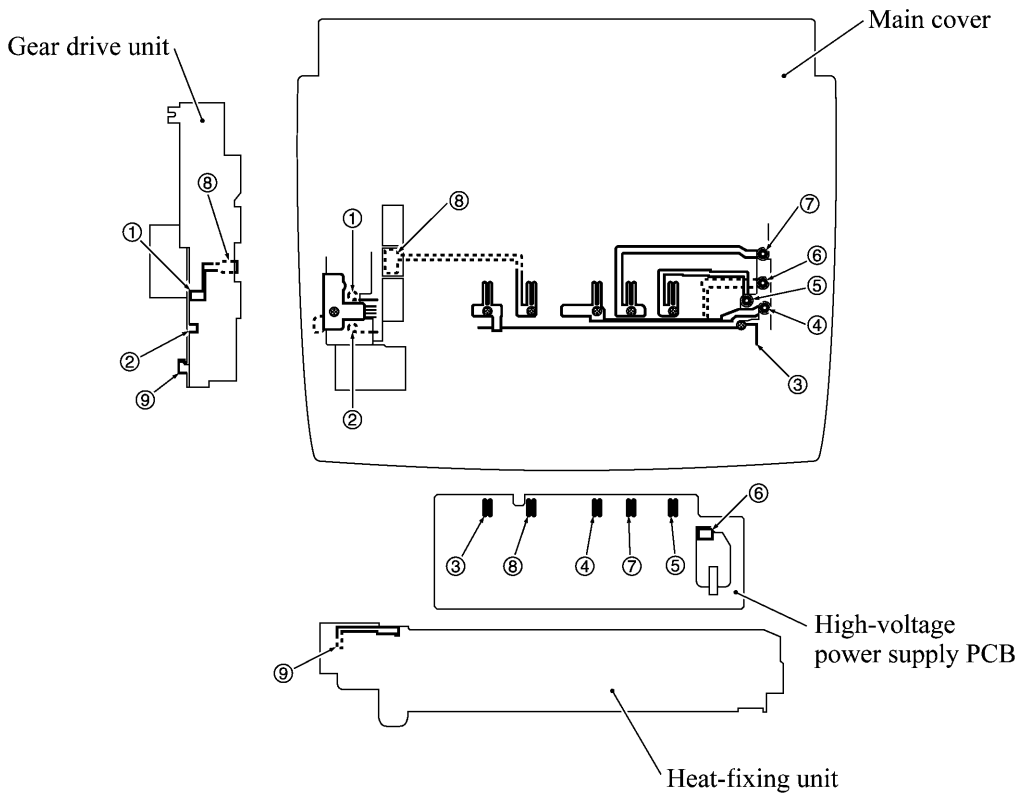
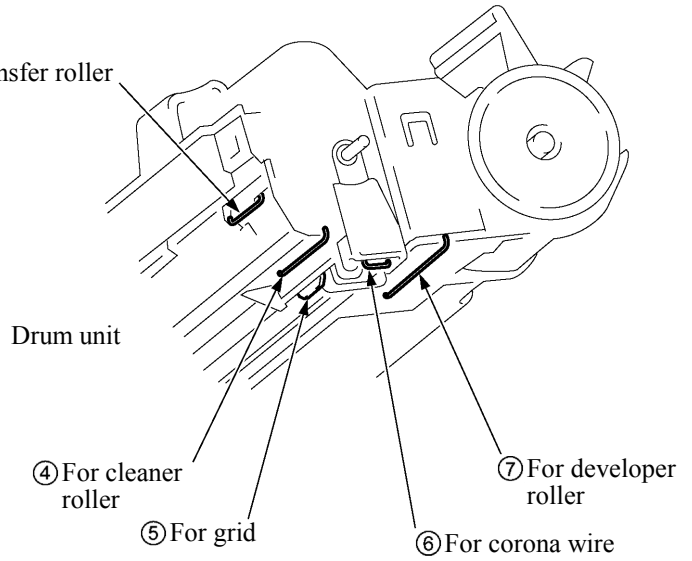

MFC6800/DCP1000
MFC9180/MFC9160

Appendix 1. EEPROM Customizing Codes

EEPROM CUSTOMIZING CODES

This function allows you to customize the EEPROM according to language, function settings, and firmware switch settings.

■ Operating Procedure

(1) For machines w/ fax

To make the machine enter the maintenance mode, press the **Menu**, *****, **2**, **8**, **6**, and **4** keys in this order. |← Within 2 seconds →|

For machines w/o fax

To make the machine enter the maintenance mode, press the **Menu**, **0**, **2**, **8**, **6**, and **4** keys in this order. |← Within 2 seconds →|

The machine beeps for approx. one second and displays "■■ MAINTENANCE ■■■" on the LCD.

(2) Press the **7** and **4** keys in this order in the initial stage of the maintenance mode.

The current customizing code (e.g., 9001 in the case of MFC6800 U.S.A. version) appears.

(3) Enter the desired customizing code (e.g., 0002 in the case of MFC6800 Canadian version).

The newly entered code appears.

***NOTE:** If a wrong 4-digit code is entered, the machine will malfunction.*

(4) For machines w/ fax Press the **Fax Start** key.

For machines w/o fax Press the **Sort** key.

The machine saves the setting and returns to the initial stage of the maintenance mode.

If you press the **Stop** key or no keys are pressed for one minute in the above procedure, the machine stops the procedure and returns to the initial stage of the maintenance mode.

■ EEPROM Customizing Codes List

Versions	Model	
	DCP1000	MFC6800
U.S.A.	0001	9001
CANADA	0002	0002
TAIWAN	0001	---

Versions	Model	
	MFC9160	MFC9180
GERMANY	0003	0003
U.K.	0004	0004
FRANCE	0005	0005
NORWAY	0007	0007
BELGIUM	0008	0008
NETHERLANDS	0009	0009
SWITZERLAND	0010	0010
IRELAND	0004	0004
FINLAND	0012	0012
DENMARK	0013	0013
AUSTRIA	0003	0003
SPAIN	0015	0015
ITALY	0016	0016
SOUTH AFRICA	0004	0004
SWEDEN	0026	0026
AUSTRALIA	0004	0006
NEW ZEALAND	0004	0027
ASIA (SINGAPORE)	0004	0040
EURO GENERIC	0050	0050

MFC6800/DCP1000
MFC9180/MFC9160

Appendix 2. Firmware Switches (WSW)

WSW No.	Function	Reference Page
WSW01	Dial pulse setting	2
WSW02	Tone signal setting	3
WSW03	PABX mode setting	4
WSW04	TRANSFER facility setting	6
WSW05	1st dial tone and busy tone detection	7
WSW06	Pause key setting and 2nd dial tone detection	9
WSW07	Dial tone setting 1	11
WSW08	Dial tone setting 2	12
WSW09	Protocol definition 1	13
WSW10	Protocol definition 2	14
WSW11	Busy tone setting	15
WSW12	Signal detection condition setting	16
WSW13	Modem setting	17
WSW14	AUTO ANS facility setting	18
WSW15	REDIAL facility setting	19
WSW16	Function setting 1	20
WSW17	Function setting 2	21
WSW18	Function setting 3	22
WSW19	Transmission speed setting in V. 17 mode	23
WSW20	Overseas communications mode setting	24
WSW21	TAD setting 1	25
WSW22	ECM setting	25
WSW23	Communications setting	26
WSW24	TAD setting 2	27
WSW25	TAD setting 3	28
WSW26	Function setting 4	29
WSW27	Function setting 5	30
WSW28	Function setting 6	31
WSW29	Function setting 7	32
WSW30	Function setting 8	32
WSW31	Function setting 9	33
WSW32	Function setting 10	34
WSW33	Function setting 11	34
WSW34	Function setting 12	35
WSW35	Function setting 13	35
WSW36	Function setting 14	36
WSW37	Function setting 15	37
WSW38	Function setting 16 in V. 34 mode	38
WSW39	Transmission speed setting in V. 34 mode	39
WSW40	Function setting 17 in V. 34 mode	40
WSW41	CCD fluorescent lamp and modem attenuator in V. 34 mode	41
WSW42	Function setting 18	42
WSW43	Function setting 19	42
WSW44	Speeding up scanning-1	43
WSW45	Speeding up scanning-2	44
WSW46	Monitor of PC ON/OFF state and delay time at the start of scanning	45

WSW01 (Dial pulse setting)

Selector No.	Function	Setting and Specifications
1 2	Dial pulse generation mode	No. 1 2 0 0 : N 0 1 : N+1 1 0 : 10-N 1 1 : N
3 4	Break time length in pulse dialing	No. 3 4 0 0 : 60 ms 0 1 : 67 ms 1 0 : 40 ms (for 16 PPS) 1 1 : 64 ms (at 106-ms intervals)
5 6	Inter-digit pause	No. 5 6 0 0 : 800 ms 0 1 : 850 ms 1 0 : 950 ms 1 1 : 600 ms
7	Switching between pulse (DP) and tone (PB) dialing, by the function switch	0: Yes 1: No
8	Default dialing mode, pulse (DP) or tone (PB) dialing	0: PB 1: DP

NOTE: In models supporting no pulse (DP) dialing mode (e.g., U.S.A. version), selector 7 takes no effect even if it may be set.

• **Selectors 1 and 2: Dial pulse generation mode**

These selectors set the number of pulses to be generated in pulse dialing.

N: Dialing "N" generates "N" pulses. (Dialing "0" generates 10 pulses.)

N + 1: Dialing "N" generates "N + 1" pulses.

10 - N: Dialing "N" generates "10 - N" pulses.

• **Selectors 3 and 4: Break time length in pulse dialing**

These selectors set the break time length in pulse dialing.

(Example: If "1," "2," and "3" are dialed when N is set by selectors 1 and 2.)

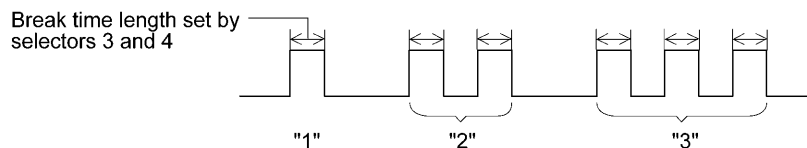

• **Selectors 5 and 6: Inter-digit pause**

These selectors set the inter-digit pause in pulse dialing.

(Example: If "1," "2," and "3" are dialed when N is set by selectors 1 and 2.)

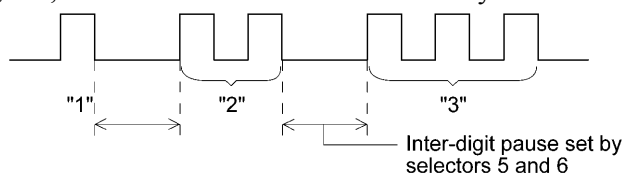

- Selector 7: Switching between pulse (DP) and tone (PB) dialing, by the function switch**
 This selector determines whether or not the dialing mode may be switched between the pulse (DP) and tone (PB) dialing by using the function switch.
- Selector 8: Default dialing mode, pulse (DP) or tone (PB) dialing**
 This selector sets the default dialing mode (pulse dialing or tone dialing) which may be changed by the function switch. If the user switches it with the function switch when selector 7 is set to "0," the setting specified by this selector will also be switched automatically.

WSW02 (Tone signal setting)

Selector No.	Function	Setting and Specifications
1 2	Tone signal transmission time length	No. 1 2 0 0 : 70 ms 0 1 : 80 ms 1 0 : 90 ms 1 1 : 100 ms
3 4	Min. pause in tone dialing	No. 3 4 0 0 : 70 ms 0 1 : 80 ms 1 0 : 90 ms 1 1 : 140 ms
5 8	Attenuator for pseudo ring backtone to the line (selectable in the range of 0-15 dB)	0 : 0 dB 1: 8 dB 0 : 0 dB 1: 4 dB 0 : 0 dB 1: 2 dB 0 : 0 dB 1: 1 dB

- Selectors 1 through 4: Tone signal transmission time length and Min. pause in tone dialing**
 These selectors set the tone signal transmission time length and minimum pause in tone dialing. (Example: If "1," "2," "3," "4," and "5" are dialed.)

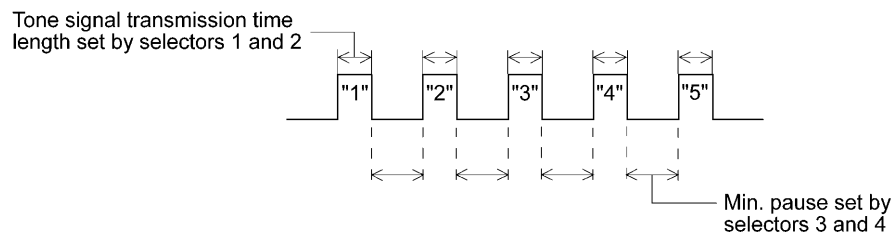

- Selectors 5 through 8: Attenuator for pseudo ring backtone to the line**
 These selectors are used to adjust the sound level of beep generated as a ring backtone in the F/T mode or as a signal during remote control operation or at the start of ICM recording. Setting two or more selectors to "1" produces addition of attenuation assigned to each selector.

WSW03 (PABX* mode setting)

Selector No.	Function	Setting and Specifications
1	CNG detection when sharing a modular wall socket with a telephone	0: A 1: B
2 4	Min. detection time length of PABX* dial tone, required for starting dialing	No. 2 3 4 0 0 0 : 50 ms 0 0 1 : 210 ms 0 1 0 : 500 ms 0 1 1 : 800 ms 1 0 0 : 900 ms 1 0 1 : 1.5 sec. 1 1 0 : 2.0 sec. 1 1 1 : 2.5 sec.
5	CNG detection when sharing a modular wall socket with a telephone	0: A 1: B
6 7	Dial tone detection in PABX*	No. 6 7 0 0 : No detection (3.5 sec. WAIT) 0 1 : No detection (5 sec. WAIT) 1 0 : No detection (7 sec. WAIT) 1 1 : Detection (Frequency only)
8	Not used.	

* PABX: Private automatic branch exchange

NOTE: Selectors 2 through 4, 6 and 7 are not applicable where no PABX is installed.

● **Selectors 1 and 5: CNG detection when sharing a modular wall socket with a telephone**

These selectors determine whether or not the machine detects a CNG signal when a line is connected to a telephone sharing a modular wall socket with the machine. Upon detection of CNG signals by the number of cycles specified by these selectors, the machine interprets CNG as an effective signal and then starts FAX reception.

Selector		Cycle
No. 1	No. 5	
0 (A)	0 (A)	0.5 cycle
0 (A)	1 (B)	1.0 cycle
1 (B)	0 (A)	1.5 cycles
1 (B)	1 (B)	2.0 cycles

● **Selectors 2 through 4: Min. detection time length of PABX dial tone, required for starting dialing**

Upon detection of the PABX dial tone for the time length set by these selectors, the machine starts dialing.

These selectors are effective only when both selectors 6 and 7 are set to "1" (Detection).

- **Selectors 6 and 7: Dial tone detection in PABX**

These selectors activate or deactivate the dial tone detection function which detects a dial tone when a line is connected to the PABX.

Setting both of these selectors to "1" activates the dial tone detection function so that the machine starts dialing upon detection of a dial tone when a line is connected.

Other setting combinations deactivate the dial tone detection function so that the machine starts dialing after the specified WAIT (3.5, 5.0, or 7.0 sec.) without detection of a dial tone when a line is connected.

WSW04 (TRANSFER facility setting)

Selector No.	Function	Setting and Specifications
1	Earth function in transfer facility	0: Provided 1: Not provided
2 4	Not used.	
5 6	Earth time length for earth function	No. 5 6 0 0 : 200 ms 0 1 : 300 ms 1 0 : 500 ms 1 1 : 700 ms
7 8	Break time length for flash function	No. 7 8 0 0 : 80 ms 0 1 : 110 ms 1 0 : 250 ms 1 1 : 500 ms

NOTE: Selectors 5 through 8 are not applicable in those countries where no transfer facility is supported.

- **Selector 1: Earth function in transfer facility**

This selector determines whether or not the earth function is added to the transfer setting menu to be accessed by the function switch.

- **Selectors 5 and 6: Earth time length for earth function**

These selectors set the short-circuiting time length of the telephone line (La or Lb) to ground.

This setting is effective only when the earth function is selected for the R key by using the function switch.

- **Selectors 7 and 8: Break time length for flash function**

These selectors set the break time length.

This setting is effective only when the flash function is selected for the R key by using the function switch.

WSW05 (1st dial tone and busy tone detection)

Selector No.	Function	Setting and Specifications
1 3	1st dial tone detection	No. 1 2 3 0 0 0 : 3.5 sec. WAIT 0 0 1 : 7.0 sec. WAIT 0 1 0 : 10.5 sec. WAIT 0 1 1 : 14.0 sec. WAIT 1 0 0 : 17.5 sec. WAIT 1 0 1 : 21.0 sec. WAIT 1 1 0 : 24.5 sec. WAIT 1 1 1 : Detection (Without WAIT)
4	Max. pause time allowable for remote ID code detection	0 : 2 seconds 1: 1 second
5 6	Busy tone detection in automatic sending mode	No. 5 6 0 0 : No detection 0 1 : Detection only after dialing 1 0 : No detection 1 1 : Detection before and after dialing
7	Busy tone detection in automatic receiving mode	0: Yes 1: No
8	Not used.	

NOTE: Selectors 5 through 7 are not applicable in those countries where no busy tone detection is supported.

- **Selectors 1 through 3: 1st dial tone detection**

These selectors activate or deactivate the 1st dial tone detection function which detects the 1st dial tone issued from the PSTN when a line is connected to the PSTN.

Setting all of these selectors to "1" activates the dial tone detection function so that the machine starts dialing upon detection of a dial tone when a line is connected. For the detecting conditions of the 1st dial tone, refer to WSW07 and WSW08.

Other setting combinations deactivate the dial tone detection function so that the machine starts dialing after the specified WAIT (3.5, 7.0, 10.5, 14.0, 17.5, 21.0, or 24.5 seconds) without detection of a dial tone when a line is connected to the PSTN.

- **Selector 4: Max. pause time allowable for remote ID code detection**

This selector sets the maximum pause time allowable for detecting the second digit of a remote ID code after detection of the first digit in remote reception.

If selector 4 is set to "0" (2 seconds), for instance, only a remote ID code whose second digit is detected within 2 seconds after detection of the first digit will become effective so as to activate the remote function.

- **Selectors 5 and 6: Busy tone detection in automatic sending mode**

These selectors determine whether or not the machine automatically disconnects a line upon detection of a busy tone in automatic sending mode.

Setting selector 6 to "0" ignores a busy tone so that the machine does not disconnect the line.

Setting selectors 5 and 6 to "0" and "1," respectively, makes the machine detect a busy tone only after dialing and disconnect the line.

Setting both of selectors 5 and 6 to "1" makes the machine detect a busy tone before and after dialing and then disconnect the line.

- **Selector 7: Busy tone detection in automatic receiving mode**

This selector determines whether or not the machine automatically disconnects a line upon detection of a busy tone in automatic receiving mode.

WSW06 (Pause key setting and 2nd dial tone detection)

Selector No.	Function	Setting and Specifications
1 3	Pause key setting and 2nd dial tone detection	No. 1 2 3 0 0 0 : No pause 0 0 1 : 3.5 sec. WAIT 0 1 0 : 7 sec. WAIT 0 1 1 : 10.5 sec. WAIT 1 0 0 : 14 sec. WAIT 1 1 0 : 2nd dial tone detection only in pulse dialing (DP) system 1 0 1 : } 2nd dial tone detection 1 1 1 : } both in DP and push-button (PB) dialing system
4 6	Detection of 2nd dial tone	No. 4 5 6 0 0 0 : 50 ms 0 0 1 : 210 ms 0 1 0 : 500 ms 0 1 1 : 800 ms 1 0 0 : 900 ms 1 0 1 : 1.5 sec. 1 1 0 : 2.0 sec. 1 1 1 : 2.5 sec.
7	No. of 2nd dial tone detection times	0: Once 1: Twice
8	2nd dial tone interrupt detecting time	0: 30 ms 1: 50 ms

- **Selectors 1 through 3: Pause key setting and 2nd dial tone detection**

Selectors			
1	2	3	
0	0	0	No WAIT is inserted even if the Pause key is pressed.
0	0	1	If you press the Pause key during dialing, the machine will insert WAIT as defined in the above table. If the Pause key is pressed repeatedly, the machine inserts the specified WAIT multiplied by the number of depressions. It applies also in hook-up dialing.
0	1	0	
0	1	1	
1	0	0	
1	0	1	When these selectors are set to "1, 0, 1": If you press the Pause key during dialing, the machine will wait for the 2nd dial tone to be sent via the communications line. When these selectors are set to "1, 1, 0" or "1, 1, 1": If you press the Pause key during dialing, the machine will first wait for the 2nd dial tone to be sent via the communications line. After that, the machine will insert a WAIT of 3.5 seconds. If no 2nd dial tone is received within the specified time length (set by WSW08), the machine will disconnect the line if in automatic dialing, or it will start transmitting the dial signal if given after depression of the Pause key in hook-up dialing.
1	1	0	
1	1	1	

- **Selectors 4 through 6: Detection of 2nd dial tone**

Upon detection of the 2nd dial tone for the time length specified by these selectors, the machine starts dialing.

This setting is effective only when the 2nd dial tone detection function is activated by selectors 1 through 3 (Setting 101, 110, or 111).

This function does not apply in those countries where no dial tone detection function is supported.

- **Selector 7: No. of 2nd dial tone detection times**

This selector sets the number of dial tone detection times required for starting dialing.

- **Selector 8: 2nd dial tone interrupt detecting time**

This selector sets the allowable time length of an interrupt which should not be interpreted as an interrupt in the 2nd tone dialing.

WSW07 (Dial tone setting 1)

Selector No.	Function	Setting and Specifications
1 2	Frequency band range	No. 1 2 0 0 : Narrows by 10 Hz 0 1 : Initial value 1 X : Widens by 10 Hz
3	Line current detection	0: No 1: Yes
4 6	2nd dial tone detection level (Z = 600 Ω)	No. 4 5 6 0 0 0 : -21 dBm 0 0 1 : -24 dBm 0 1 0 : -27 dBm 0 1 1 : -30 dBm 1 0 0 : -33 dBm 1 0 1 : -36 dBm 1 1 0 : -39 dBm 1 1 1 : -42 dBm
7	1st dial tone interrupt detecting time	0: 30 ms 1: 50 ms
8	Not used.	

NOTE: Selectors 1 through 7 are not applicable in those countries where no dial tone or line current detection is supported, e.g., U.S.A.

- **Selectors 1 and 2: Frequency band range**

These selectors set the frequency band for the 1st dial tone and the busy tone (before dialing) to be detected.

This setting is effective only when selectors 1 through 3 of WSW05 are set to "1,1,1."

- **Selector 3: Line current detection**

This selector determines whether or not the machine should detect a line current before starting dialing.

- **Selectors 4 through 6: 2nd dial tone detection level**

These selectors set the detection level of the 2nd dial tone.

- **Selector 7: 1st dial tone interrupt detecting time**

This selector sets the allowable time length of an interrupt which should not be interpreted as an interrupt in the 1st dial tone dialing.

WSW08 (Dial tone setting 2)

Selector No.	Function	Setting and Specifications
1 3	1st dial tone detection time length	No. 1 2 3 0 0 0 : 50 ms 0 0 1 : 210 ms 0 1 0 : 500 ms 0 1 1 : 800 ms 1 0 0 : 900 ms 1 0 1 : 1.5 sec. 1 1 0 : 2.0 sec. 1 1 1 : 2.5 sec.
4 5	Time-out length for 1st and 2nd dial tone detection	No. 4 5 0 0 : 10 sec. 0 1 : 20 sec. 1 0 : 15 sec. 1 1 : 30 sec.
6 8	Detection level of 1st dial tone and busy tone before dialing	No. 6 7 8 0 0 0 : -21 dBm 0 0 1 : -24 dBm 0 1 0 : -27 dBm 0 1 1 : -30 dBm 1 0 0 : -33 dBm 1 0 1 : -36 dBm 1 1 0 : -39 dBm 1 1 1 : -42 dBm

NOTE: The WSW08 is not applicable in those countries where no dial tone detection is supported, e.g., U.S.A.

● **Selectors 1 through 3: 1st dial tone detection time length**

Upon detection of the 1st dial tone for the time length set by these selectors, the machine starts dialing.

This setting is effective only when selectors 1 through 3 of WSW05 are set to "1,1,1."

● **Selectors 4 and 5: Time-out length for 1st and 2nd dial tone detection**

These selectors set the time-out length for the 1st and 2nd dial tone detection so that the machine waits dial tone input for the specified time length and disconnects itself from the line when no dial tone is inputted.

WSW09 (Protocol definition 1)

Selector No.	Function	Setting and Specifications	
1	Frame length selection	0: 256 octets 1: 64 octets	
2	Use of non-standard commands	0: Allowed 1: Prohibited	
3 4	No. of retries	No. 3 4 0 0 : 4 times 0 1 : 3 times 1 0 : 2 times 1 1 : 1 time	
5		T5 timer	0: 300 sec. 1: 60 sec.
6		T1 timer	0: 35 sec. 1: 40 sec.
7 8		Elapsed time for time-out control for no response from the called station in automatic sending mode	No. 7 8 0 0 : 60 sec. (55 sec. for US and Canada) 0 1 : 140 sec. 1 0 : 90 sec. 1 1 : 35 sec.

NOTE: Selectors 1 through 6 are not applicable in those models which do not support ECM.

- **Selector 1: Frame length selection**

Usually a single frame consists of 256 octets (1 octet = 8 bits). For communications lines with higher bit error rate, however, set selector 1 to "1" so that the machine can divide a message into 64-octet frames.

Remarks: The error correction mode (ECM) is a facsimile transmission manner in which the machine divides a message into frames for transmission so that if any data error occurs on the transmission line, the machine retransmits only those frames containing the error data.

- **Selector 2: Use of non-standard commands**

If this selector is set to "0," the machine may use non-standard commands (the machine's native-mode commands, e.g., NSF, NSC, and NSS) for communications. If it is set to "1," the machine will use standard commands only.

- **Selectors 3 and 4: No. of retries**

These selectors set the number of retries in each specified modem transmission speed.

- **Selector 5: T5 timer**

This selector sets the time length for the T5 timer.

- **Selector 6: T1 timer**

This selector sets the time length for the T1 timer.

- **Selectors 7 and 8: Elapsed time for time-out control**

If the machine receives no response (no G3 command) from the called terminal in automatic sending during the time set by these selectors, it disconnects the line.

WSW10 (Protocol definition 2)

Selector No.	Function	Setting and Specifications
1	Switching of DPS, following the CML ON/OFF	0: No 1: Yes
2	Time length from transmission of the last dial digit to CML ON	0: 100 ms 1: 50 ms
3	Time length from CML ON to CNG transmission	0: 2 sec. 1: 4 sec.
4	Time length from CML ON to CED transmission (except for facsimile-to-telephone switching)	0: 0.5 sec. 1: 2 sec.
5 6	No. of training retries	No. 5 6 0 0 : 1 time 0 1 : 2 times 1 0 : 3 times 1 1 : 4 times
7	Encoding system (Compression)	MR 0: Allowed 1: Not allowed
8		MMR 0: Allowed 1: Not allowed

- **Selector 1: Switching of DPS, following the CML ON/OFF**
Setting this selector to "1" automatically switches DPS following the CML ON/OFF operation.
- **Selector 2: Time length from transmission of the last dial digit to CML ON**
This selector sets the time length from when the machine transmits the last dial digit until the CML relay comes on.
- **Selector 3: Time length from CML ON to CNG transmission**
This selector sets the time length until the machine transmits a CNG after it turns on the CML relay.
- **Selector 4: Time length from CML ON to CED transmission**
This selector sets the time length until the machine transmits a CED after it turns on the CML relay. This setting does not apply to switching between facsimile and telephone.
- **Selectors 5 and 6: No. of training retries**
These selectors set the number of training retries to be repeated before automatic fallback.
- **Selectors 7 and 8: Encoding system (Compression)**
This selector determines whether or not use of the MR/MMR coding system will be allowed.

WSW11 (Busy tone setting)

Selector No.	Function	Setting and Specifications
1 2	Frequency band range	No. 1 2 0 0 : Narrows by 10 Hz 0 1 : Initial value 1 x : Widens by 10 Hz
3	Not used.	
4	ON/OFF time length ranges (More than one setting allowed)	1: 400-600/400-600 ms
5		1: 175-440/175-440 ms
6		1: 100-1000/17-660 ms
7		1: 110-410/320-550 ms
8		1: 100-660/100-660 ms

NOTE: WSW11 is not applicable in those countries where no busy tone detection is supported.

NOTE: The setting of WSW11 is effective only when selectors 5 and 6 of WSW05 are set to "0, 1" or "1, 1" (Busy tone detection).

- **Selectors 1 and 2: Frequency band range**

These selectors set the frequency band for busy tone to be detected.

- **Selectors 4 through 8: ON/OFF time length ranges**

These selectors set the ON and OFF time length ranges for busy tone to be detected. If more than one selector is set to "1," the ranges become wider. For example, if selectors 4 and 5 are set to "1," the ON and OFF time length ranges are from 175 to 600 ms.

WSW12 (Signal detection condition setting)

Selector No.	Function	Setting and Specifications
1 2	Min. OFF time length of calling signal (Ci)	No. 1 2 0 0 : 1500 ms 0 1 : 500 ms 1 0 : 700 ms 1 1 : 900 ms
3 4	Max. OFF time length of calling signal (Ci)	No. 3 4 0 0 : 6 sec. 0 1 : 7 sec. 1 0 : 9 sec. 1 1 : 11 sec.
5 6	Detecting time setting	No. 5 6 0 0 : 800 ms 0 1 : 200 ms 1 0 : 250 ms 1 1 : 150 ms
7	Delay	0: Yes 1: No
8	Not used.	

- **Selectors 1 through 4: Min. and max. OFF time length of calling signal (Ci)**

If the machine detects the OFF state of calling signal (Ci) for a time length which is greater than the value set by selectors 1 and 2 and less than the value set by selectors 3 and 4, then it interprets the Ci signal as OFF.

- **Selectors 5 and 6: Detecting time setting**

These selectors set the time length required to make the machine acknowledge itself to be called. That is, if the machine continuously detects calling signals with the frequency set by selectors 1 through 4 of WSW14 during the time length set by these selectors 5 and 6, then it acknowledges the call.

- **Selector 7: Delay**

Setting this selector to "0" allows the machine to insert a 900 ms WAIT after acknowledgment of the call until the machine turns on the CML relay to start receiving operation.

WSW13 (Modem setting)

Selector No.	Function	Setting and Specifications
1 2	Cable equalizer	No. 1 2 0 0 : 0 km 0 1 : 1.8 km 1 0 : 3.6 km 1 1 : 5.6 km
3 4	Reception level	No. 3 4 0 0 : -43 dBm 0 1 : -47 dBm 1 0 : -49 dBm 1 1 : -51 dBm
5 8	Modem attenuator	0: 0 dB 1: 8 dB 0: 0 dB 1: 4 dB 0: 0 dB 1: 2 dB 0: 0 dB 1: 1 dB

The modem should be adjusted according to the user's line conditions.

- **Selectors 1 and 2: Cable equalizer**

These selectors are used to improve the pass-band characteristics of analogue signals on a line. (Attenuation in the high-band frequency is greater than in the low-band frequency.)

Set these selectors according to the distance from the telephone switchboard to the machine.

- **Selectors 3 and 4: Reception level**

These selectors set the optimum receive signal level.

- **Selectors 5 through 8: Modem attenuator**

These selectors are used to adjust the transmitting level of the modem when the reception level at the remote station is improper due to line loss. This function applies to G3 protocol signals.

Setting two or more selectors to "1" produces addition of attenuation assigned to each selector.

This setting will be limited if selector 8 of WSW23 is set to "0."

WSW14 (AUTO ANS facility setting)

Selector No.	Function	Setting and Specifications
1 2	Frequency band selection (Lower limit)	No. 1 2 0 0 : 13 Hz 0 1 : 15 Hz 1 0 : 23 Hz 1 1 : 20 Hz
3 4	Frequency band selection (Upper limit)	No. 3 4 0 0 : 30 Hz 0 1 : 55 Hz 1 0 : 70 Hz 1 1 : 200 Hz
5 8	No. of rings in AUTO ANS mode	No. 5 6 7 8 0 0 0 0 : Fixed to once 0 0 0 1 : Fixed to 2 times 0 0 1 0 : Fixed to 3 times 0 0 1 1 : Fixed to 4 times 0 1 0 0 : 1 to 2 times 0 1 0 1 : 1 to 3 times 0 1 1 0 : 1 to 4 times 0 1 1 1 : 1 to 5 times 1 0 0 0 : 2 to 3 times 1 0 0 1 : 2 to 4 times 1 0 1 0 : 2 to 5 times 1 0 1 1 : 2 to 6 times 1 1 0 0 : 1 to 10 times 1 1 0 1 : 2 to 10 times 1 1 1 0 : 3 to 5 times 1 1 1 1 : 4 to 10 times

- **Selectors 1 through 4: Frequency band selection**

These selectors are used to select the frequency band of calling signals for activating the AUTO ANS facility.

In the French versions, if the user sets the PBX to OFF from the control panel, the setting made by selectors 1 and 2 will take no effect and the frequency's lower limit will be fixed to 32 Hz. (Even if the setting made by these selectors does not apply, it will be printed on the configuration list.)

- **Selectors 5 through 8: No. of rings in AUTO ANS mode**

These selectors set the number of rings to initiate the AUTO ANS facility.

WSW15 (REDIAL facility setting)

Selector No.	Function	Setting and Specifications
1 2	Selection of redial interval	No. 1 2 0 0 : 5 minutes 0 1 : 1 minute 1 0 : 2 minutes 1 1 : 3 minutes
3 6	No. of redialings	No. 3 4 5 6 0 0 0 0 : 16 times 0 0 0 1 : 1 times 0 0 1 0 : 2 times 0 0 1 1 : 3 times 1 1 1 1 : 15 times
7	Redialing for no response sent from the called terminal	0: Redialing 1: No redialing
8	Not used.	

NOTE: Selector 7 is not applicable in those countries where no busy tone detection is supported.

- **Selectors 1 through 6: Selection of redial interval and No. of redialings**

The machine redials by the number of times set by selectors 3 through 6 at intervals set by selectors 1 and 2.

This setting is effective only when selector 7 is set to "0."

- **Selectors 7: Redialing for no response sent from the called terminal**

This selector determines whether or not the machine redials if no G3 command response comes from the called station after dialing within the time length set by selectors 7 and 8 of WSW09.

WSW16 (Function setting 1)

Selector No.	Function	Setting and Specifications
1	Not used.	
2	CCITT superfine recommendation	0: OFF 1: ON
3 6	Not used.	
7	Max. document length limitation	0: 400 cm 1: 90 cm
8	Stop key pressed during reception	0: Not functional 1: Functional

- **Selector 2: CCITT superfine recommendation**

If this selector is set to "1," the machine communicates in CCITT recommended superfine mode (15.4 lines/mm). If it is set to "0," it communicates in native superfine mode.

- **Selector 7: Max. document length limitation**

This selector is used to select the maximum length of a document to be sent.

- **Selector 8: Stop key pressed during reception**

If this selector is set to "1," pressing the **Stop** key can stop the current receiving operation. The received data will be lost.

WSW17 (Function setting 2)

Selector No.	Function	Setting and Specifications
1 2	Off-hook alarm	No. 1 2 0 0 : No alarm 0 1 : Always valid 1 X : Valid except when 'call reservation' is selected.
3 4	Not used.	
5	Calendar clock type	0: U.S.A. type 1: European type
6	Not used.	
7	Non-ring reception	0: OFF 1: ON
8	Not used.	

- **Selectors 1 and 2: Off-hook alarm**

These selectors activate or deactivate the alarm function which sounds an alarm when the communication is completed with the handset being off the hook.

- **Selector 5: Calendar clock type**

If this selector is set to "0" (USA), the MM/DD/YY hh:mm format applies; if it is set to "1" (Europe), the DD/MM/YY hh:mm format applies: DD is the day, MM is the month, YY is the last two digits of the year, hh is the hour, and mm is the minute.

- **Selector 7: Non-ring reception**

Setting this selector to "1" makes the machine receive calls without ringer sound if the ring delay is set to 0.

WSW18 (Function setting 3)

Selector No.	Function	Setting and Specifications
1	Not used.	
2 3	Detection enabled time for CNG and no tone	No. 2 3 0 0 : 40 sec. 0 1 : 0 sec. (No detection) 1 0 : 5 sec. 1 1 : 80 sec.
4 5	Not used.	
6	Registration of station ID	0: Permitted 1: Prohibited
7 8	Tone sound monitoring	No. 7 8 0 X : No monitoring 1 0 : Up to phase B at the calling station only 1 1 : All transmission phases both at the calling and called stations

- **Selectors 2 and 3: Detection enabled time for CNG and no tone**

After the line is connected via the external telephone or by picking up the handset of the machine, the machine can detect a CNG signal or no tone for the time length specified by these selectors. The setting specified by these selectors becomes effective only when selector 8 of WSW20 is set to "1."

- **Selectors 7 and 8: Tone sound monitoring**

These selectors set monitoring specifications of the tone sound inputted from the line.

WSW19 (Transmission speed setting in V. 17 mode)

Selector No.	Function	Setting and Specifications
1 3	First transmission speed choice for fallback	No. 1 2 3 No. 4 5 6 0 0 0 : 2,400 bps 0 0 1 : 4,800 bps 0 1 0 : 7,200 bps 0 1 1 : 9,600 bps 1 0 0 : 12,000 bps 1 0 1 : } 1 1 0 : } 14,400 bps 1 1 1 : }
4 6	Last transmission speed choice for fallback	
7	V. 34 mode	0: Permitted 1: Prohibited
8	V. 17 mode	0: Permitted 1: Prohibited

NOTE: For the transmission speed setting in V.34 mode, refer to WSW39.

- **Selectors 1 through 6: First and last choices of transmission speed for fallback**

These selectors are used to set the modem speed range. With the first transmission speed choice specified by selectors 1 through 3, the machine attempts to establish the transmission link via the modem. If the establishment fails, the machine automatically steps down to the next highest speed and attempts to establish the transmission link again. The machine repeats this sequence while stepping down the transmission speed to the last choice specified by selectors 4 through 6.

If the modem always falls back to a low transmission speed (e.g., 4,800 bps), set the first transmission speed choice to the lower one (e.g., modify it from 12,000 bps to 7,200 bps) in order to deactivate the high-speed modem function and reduce the training time for shorter transmission time.

Generally, to save the transmission time, set the last transmission speed choice to a higher one.

- **Selector 7: V. 34 mode**

This selector determines whether or not the machine communicates with the remote station in the V. 34 mode when that station supports the V. 34 mode.

WSW20 (Overseas communications mode setting)

Selector No.	Function	Setting and Specifications
1	EP* tone prefix	0: OFF 1: ON
2	Overseas communications mode (Reception)	0: 2100 Hz 1: 1100 Hz
3	Overseas communications mode (Transmission)	0: OFF 1: Ignores DIS once.
4 5	Min. time length from reception of CFR to start of transmission of video signals	No. 4 5 0 0 : 100 ms 0 1 : 200 ms 1 0 : 300 ms 1 1 : 400 ms
6 7	Chattering noise elimination at detection of CNG	No. 6 7 0 0 : Yes (When CNG goes either ON or OFF) 0 1 : Yes (Only when CNG goes OFF) 1 0 : No 1 1 : No
8	CNG detection on/off	0: OFF 1: ON

* EP: Echo protection

- **Selector 1: EP tone prefix**

Setting this selector to "1" makes the machine transmit a 1700 Hz echo protection (EP) tone immediately preceding training in V.29 modulation system to prevent omission of training signals.

Prefixing an EP tone is effective when the machine fails to transmit at the V.29 modem speed and always has to fall back to 4800 bps transmission.

- **Selectors 2 and 3: Overseas communications mode**

These selectors should be used if the machine malfunctions in overseas communications. According to the communications error state, select the signal specifications.

Setting selector 2 to "1" allows the machine to use 1100 Hz CED signal instead of 2100 Hz in receiving operation. This prevents malfunctions resulting from echoes, since the 1100 Hz signal does not disable the echo suppressor (ES) while the 2100 Hz signal does.

Setting selector 3 to "1" allows the machine to ignore a DIS signal sent from the called station once in sending operation. This operation suppresses echoes since the first DIS signal immediately follows a 2100 Hz CED (which disables the ES) so that it is likely to be affected by echoes in the disabled ES state. However, such a disabled ES state will be removed soon so that the second and the following DIS signals are not susceptible to data distortion due to echoes. Note that some models when called may cause error by receiving a self-outputted DIS.

- **Selectors 8: CNG detection on/off**

If this selector is set to "1," the machine detects a CNG signal according to the condition preset by selectors 2 and 3 of WSW18 after a line is connected. If it is set to "0," the machine detects a CNG signal as long as the line is connected.

WSW21 (TAD setting 1)

Selector No.	Function	Setting and Specifications
1 7	Not used.	
8	Erasure of message stored in the memory after the message transfer	0: Yes 1: No

● **Selector 8: Erasure of message**

Setting this selector to "0" will erase the message recorded in the memory after the document retrieval feature transfers the message.

WSW22 (ECM setting)

Selector No.	Function	Setting and Specifications
1	ECM* in sending	0: ON 1: OFF
2	ECM* in receiving	0: ON 1: OFF
3	Call Waiting Caller ID	0: ON 1: OFF
4	Not used.	
5 8	Acceptable TCF bit error rate (%) (Only at 4800 bps)	0: 0% 1: 8% 0: 0% 1: 4% 0: 0% 1: 2% 0: 0% 1: 1%

* ECM: Error correction mode

NOTE: Selector 3 is applicable to the American version only, but not applicable to those models equipped with high-speed modem.

NOTE: Selectors 5 through 8 are applicable to the Asian version only.

● **Selector 3: Call Waiting Caller ID**

Setting this selector to "0" allows the user to decide whether or not to interrupt the current call when a new call comes in. If Call Waiting Caller ID service is available in the area and the user subscribes to it, he/she can see information about his/her incoming call.

● **Selectors 5 through 8: Acceptable TCF bit error rate (%)**

Setting two or more selectors to "1" produces addition of percent assigned to each selector. If you set selectors 7 and 8 to "1," the acceptable TCF bit error rate will be 3%.

WSW23 (Communications setting)

Selector No.	Function	Setting and Specifications
1	Starting point of training check (TCF)	0: From the head of a series of zeros 1: From any arbitrary point
2 3	Allowable training error rate	No. 2 3 0 0 : 0% 0 1 : 0.5% 1 0 : 1% 1 1 : 2%
4 5		No. 4 5 0 0 : 16% 0 1 : 14% 1 0 : 10% 1 1 : 8%
6 7	Not used.	
8	Limitation of attenuation level	0: Yes 1: No

NOTE: Selector 8 is not applicable to the French versions.

● **Selector 1: Starting point of training check (TCF)**

At the training phase of receiving operation, the called station detects for 1.0 second a training check (TCF) command, a series of zeros which is sent from the calling station for 1.5 seconds to verify training and give the first indication of the acceptability of the line.

This selector sets the starting point from which the called station should start counting those zeros. If this selector is set to "0," the called station starts counting zeros 100 ms after the head of a series of zeros is detected.

If it is set to "1," the called station starts counting zeros upon detection of 10-ms successive zeros 50 ms after the head of a series of zeros is detected. In this case, if the detection of 10-ms successive zeros is too late, the data counting period will become less than 1.0 second, making the called station judge the line condition unacceptable.

● **Selectors 2 and 3: Allowable training error rate**

The called station checks a series of zeros gathered in training (as described in Selector 1) according to the allowable training error rate set by these selectors. If the called station judges the line condition to be accepted, it responds with CFR; if not, it responds with FTT.

● **Selectors 4 and 5: Decoding error rate for transmission of RTN**

The machine checks the actual decoding errors and then transmits an RTN according to the decoding error rate (Number of lines containing an error per page ÷ Total number of lines per page) set by these selectors.

● **Selector 8: Limitation of attenuation level**

Setting this selector to "0" limits the transmitting level of the modem to 10 dB.

This setting has priority over the settings selected by WSW02 (selectors 5 through 8) and WSW13 (selectors 5 through 8).

WSW24 (TAD setting 2)

Selector No.	Function	Setting and Specifications
1 2	Not used.	
3 4	Time length from CML ON to start of pseudo ring backtone transmission	No. 3 4 0 0 : 4 sec. 0 1 : 3 sec. 1 0 : 2 sec. 1 1 : 1 sec.
5 8	Attenuator for playback of ICM/OGM to the line (Selectable from the range of 0-15 dB)	0: 0 dB 1: 8 dB 0: 0 dB 1: 4 dB 0: 0 dB 1: 2 dB 0: 0 dB 1: 1 dB

- **Selectors 3 and 4: Time length from CML ON to start of pseudo ring backtone transmission**

These selectors set the length of time from CML-ON up to the start of pseudo ring backtone transmission.

In those versions which have an OGM facility, the settings made by these selectors also apply to the length of time from CML-ON up to the start of OGM transmission.

- **Selectors 5 through 8: Attenuator for playback of ICM/OGM to the line**

Setting two or more selectors to "1" produces addition of attenuation assigned to each selector.

This setting will not be limited by selector 8 of WSW23.

WSW25 (TAD setting 3)

Selector No.	Function	Setting and Specifications
1 2	Delay time for starting detection of voice signal	No. 1 2 0 0 : 0 sec. 0 1 : 8 sec. 1 0 : 16 sec. 1 1 : 24 sec.
3 4	Detection level for no voice signal	No. 3 4 0 0 : -43 dB (A) 0 1 : -46 dB (B) 1 0 : -49 dB (C) 1 1 : -51 dB (D)
5 7	Pause between paging number and PIN	No. 5 6 7 0 0 0 : 2 sec. 0 0 1 : 4 sec. 0 1 0 : 6 sec. 0 1 1 : 8 sec. 1 0 0 : 10 sec. 1 0 1 : 12 sec. 1 1 0 : 14 sec. 1 1 1 : 16 sec.
8	Not used.	

NOTE: Selectors 1 through 4 are not applicable to the U.S.A. versions.

NOTE: Selectors 5 through 7 are applicable to those models equipped with a built-in TAD.

● **Selectors 1 and 2: Delay time for starting detection of voice signal**

These selectors take effect only in TAD mode (when the external TAD is connected to the machine). The machine delays starting detection of the voice signal by the time length specified by these selectors.

The total length of the delay time specified by these selectors and the maximum waiting time specified by WSW21 (selectors 1 through 5) should not exceed 40 seconds.

● **Selectors 3 and 4: Detection level for no voice signal**

These selectors set the detection level for no voice signal in the TAD mode (when the external TAD is connected to the machine).

● **Selectors 5 through 7: Pause between paging number and PIN**

These selectors set the pause time between a telephone number being paged and PIN (private identification number) for the paging feature.

WSW26 (Function setting 4)

Selector No.	Function	Setting and Specifications
1 2	Not used.	
3	Dialing during document reading into the temporary memory in in-memory message transmission	0: Disabled 1: Enabled
4 5	No. of CNG cycles to be detected (when the line is connected via the external telephone except in the external TAD mode or via the built-in telephone of the machine)	No. 4 5 0 0 : 0.5 (A) 0 1 : 1 (B) 1 0 : 1.5 (C) 1 1 : 2 (D)
6 8	Not used.	

● **Selector 3: Dialing during document reading into the temporary memory in in-memory message transmission**

If this selector is set to "0," the machine waits for document reading into the memory to complete and then starts dialing. This enables the machine to list the total number of pages in the header of the facsimile message.

● **Selectors 4 and 5: No. of CNG cycles to be detected**

The machine interprets a CNG as an effective signal if it detects a CNG signal by the number of cycles specified by these selectors in any of the following cases:

- when the line is connected via the external telephone except in the external TAD mode.
- when the line is connected via the built-in telephone of the machine.

WSW27 (Function setting 5)

Selector No.	Function	Setting and Specifications
1	Definition of programmable key	0: TEL key 1: TEL/POLLING key
2	Ringer OFF setting	0: Yes 1: No
3	Not used.	
4	Detection of distinctive ringing pattern	0: Yes 1: No
5 7	Not used.	
8	Toner save mode	0: Yes 1: No

NOTE: Selector 1 takes effect only in models/versions having a TEL key.

NOTE: Selector 4 is applicable only to the U.S.A. version.

- **Selector 1: Definition of programmable key**

This selector defines a programmable key as a TEL key or TEL/POLLING key.

Setting this selector to "1" allows the programmable key to function as either a TEL or POLLING key if pressed when the handset is off or on the hook, respectively.

- **Selector 2: Ringer OFF setting**

This selector determines whether or not the ringer can be set to OFF.

- **Selector 4: Detection of distinctive ringing pattern**

If this selector is set to "1," the machine detects only the number of rings; if it is set to "0," the machine detects the number of rings and the ringing time length to compare the detected ringing pattern with the registered distinctive one.

WSW28 (Function setting 6)

Selector No.	Function	Setting and Specifications
1 3	Transmission level of DTMF high-band frequency signal	No. 1 2 3 0 0 0 : 0 dB 0 0 1 : +1 dB 0 1 0 : +2 dB 0 1 1 : +3 dB 1 0 0 : 0 dB 1 0 1 : -1 dB 1 1 0 : -2 dB 1 1 1 : -3 dB
4 6	Transmission level of DTMF low-band frequency signal	No. 4 5 6 0 0 0 : 0 dB 0 0 1 : +1 dB 0 1 0 : +2 dB 0 1 1 : +3 dB 1 0 0 : 0 dB 1 0 1 : -1 dB 1 1 0 : -2 dB 1 1 1 : -3 dB
7 8	Not used.	

• **Selectors 1 through 6: Transmission level of DTMF high-/low-band frequency signal**

These selectors are intended for the manufacturer who tests the machine for the Standard. Never access them.

WSW29 (Function setting 7)

Selector No.	Function	Setting and Specifications
1 6	Not used.	
7	Impedance switching control in pulse dialing	0: OFF 1: ON
8	Beep when the memory area for the activity report becomes full	0: No 1: Yes

NOTE: Selectors 7 and 8 are applicable to the European version only.

- **Selector 8: Beep when the memory area for the activity report becomes full**

If this selector is set to "1," the machine will beep when the memory area for the activity report becomes full (as well as displaying a message on the LCD, prompting the output of the activity report).

WSW30 (Function setting 8)

Selector No.	Function	Setting and Specifications
1 3	Not used.	
4	Duty cycle control of pulsed current for the heat-fixing unit	0: OFF 1: ON
5 8	Not used.	

NOTE: Selector 4 is applicable to the European version only.

- **Selector 4: Duty cycle control of pulsed current for the heat-fixing unit**

Setting this selector to "1" activates the duty cycle control that suppresses the rush current. The duty cycle is 10-ms ON and 20-ms OFF.

However, the duty cycle control may emit switching noise to the AC line. Depending upon the codes and regulations in the country, this selector should be set to "0."

WSW31 (Function setting 9)

Selector No.	Function	Setting and Specifications
1	Not used.	
2	Default reduction rate for failure of automatic reduction during recording	0: 100% 1: Reduction rate specified according to the current paper size
3 4	Not used.	
5	Minimum short-OFF duration in distinctive ringing	0: 130 ms 1: 90 ms
6 7	Not used.	
8	"CHANGE DRUM SOON" message	0: Yes 1: No

- **Selector 2: Default reduction rate for failure of automatic reduction during recording**

This selector sets the default reduction rate to be applied if the automatic reduction function fails to record one-page data sent from the calling station in a single page of the current recording paper.

If it is set to "0," the machine records one-page data at full size (100%) without reduction; if it is set to "1," the machine records it at the size specified according to the current paper size.

- **Selector 5: Minimum short-OFF duration in distinctive ringing**

The ringer pattern consists of short and long rings, e.g., short-short-long rings. This selector sets the minimum OFF duration following a short ring in order to avoid missing ringer tones in distinctive ringing.

If this selector is set to "1," when the short-OFF duration is a minimum of 90 ms long, then the machine will interpret the short-OFF as OFF.

- **Selector 8: "CHANGE DRUM SOON" message**

This selector determines whether or not the "CHANGE DRUM SOON" message should appear on the LCD when the service life of the laser-sensitive drum in the laser unit will expire soon.

WSW32 (Function setting 10)

Selector No.	Function	Setting and Specifications
1 4	Not used.	
5 6	Default resolution	No. 5 6 0 0 : Standard 0 1 : Fine 1 0 : Super fine 1 1 : Photo
7 8	Default contrast	No. 7 8 0 X : Automatic 1 0 : Super light 1 1 : Super dark

- **Selectors 5 and 6: Default resolution**

These selectors set the default resolution which applies when the machine is powered up or completes a transaction.

- **Selectors 7 and 8: Default contrast**

These selectors set the default contrast which applies when the machine is powered up or completes a transaction.

WSW33 (Function setting 11)

Selector No.	Function	Setting and Specifications
1 5	Not used.	
6	Report output of polled transmission requests	0: Yes 1: No
7 8	Not used.	

NOTE: Selector 6 is not applicable to American versions.

WSW34 (Function setting 12)

Selector No.	Function	Setting and Specifications
1 3	Not used.	
4 5	No. of CNG cycles to be detected (when the line is connected via the machine in the F/T mode or via the external telephone in the external TAD mode)	No. 4 5 0 0 : 0.5 (A) 0 1 : 1 (B) 1 0 : 1.5 (C) 1 1 : 2 (D)
6 7	Number of DTMF tone signals for inhibiting the detection of CNG during external TAD operation	No. 6 7 0 0 : 3 0 1 : 2 1 0 : 1 1 1 : OFF
8	CNG detection when the external telephone is connected with a line in TAD mode	0: Only when the machine detects itself being called 1: Always

NOTE: Selectors 4 and 5 are not applicable to the American version.

● **Selectors 4 and 5: No. of CNG cycles to be detected**

The machine interprets a CNG as an effective signal if it detects a CNG signal by the number of cycles specified by these selectors when the line is connected via the machine in the F/T mode or via the external telephone in the external TAD mode.

● **Selectors 6 and 7: Number of DTMF tone signals for inhibiting the detection of CNG during external TAD operation**

If the machine receives this specified number of DTMF tone signals during external TAD operation, then it will not detect CNG afterwards.

If these selectors are set to "1, 1," the CNG detection will not be inhibited.

● **Selector 8: CNG detection when the external telephone is connected with a line in TAD mode**

If this selector is set to "0," the machine will detect a CNG signal only when it detects itself being called. If the external telephone is connected with a line before the machine detects itself being called, the machine will no longer detect a CNG signal.

If this selector is set to "1," the machine will detect a CNG signal every time the external telephone is connected with a line, even without detecting itself being called.

WSW35 (Function setting 13)

Selector No.	Function	Setting and Specifications
1 8	Not used.	

WSW36 (Function setting 14)

Selector No.	Function	Setting and Specifications
1	ECP* mode	0: ON 1: OFF
2	Recovery from inactive PC interface	0: Disabled 1: Enabled
3	PC power-off recognition time	0: Normal 1: Long
4	Not used.	
5	Escape from phase C	0: Yes 1: No
6 8	Lower limit of frequency to be ignored after detection of calling signals (Ci)	No. 6 7 8 0 0 0 : 0 (Not ignored) 0 0 1 : 4 (448 Hz) 0 1 0 : 8 (244 Hz) 0 1 1 : 12 (162 Hz) 1 0 0 : 16 (122 Hz) 1 0 1 : 20 (97 Hz) 1 1 0 : 24 (81 Hz) 1 1 1 : 28 (69 Hz)

*ECP (Enhanced Capabilities Port)

- **Selector 1: ECP mode**

The ECP mode enhances the normal bidirectional communications between the machine and the connected PC for higher transmission speed.

- **Selector 2: Recovery from inactive PC interface**

If the machine recognizes via the STROBE signal line that the connected PC is powered off, then it will turn the PC interface output Low to protect the PC from hazards that could be caused by weak electric current accidentally flown from the machine.

This selector determines whether the machine should recover from the inactive PC interface to normal interfacing state upon receipt of data from the PC.

- **Selector 3: PC power-off recognition time**

This selector sets the time length from when the machine detects the PC powered off until it recognizes the detected state as power-off.

If selector 2 is set to "0," it is recommended that selector 3 be set to "1": otherwise, the machine may mistakenly detect PC powered off.

- **Selector 5: Escape from phase C**

This selector determines whether or not the machine will escape from phase C when it detects an RTC (Return to Control) in non-ECM mode or an RCP (Return to Control Partial page) in ECM mode.

- **Selectors 6 through 8: Lower limit of frequency to be ignored after detection of calling signals (Ci)**

At the start of reception, if the machine detects the frequency of calling signals (Ci) specified by selectors 1 through 4 of WSW14, it will start the ringer sounding. When doing so, the machine may fail to detect the calling signals normally due to noises superimposed at the time of reception. To prevent it, use selectors 6 through 8 of WSW36.

If the machine detects higher frequencies than the lower limit specified by these selectors, then it will regard them as noise and interpret that detecting state as being normal, allowing the ringer to keep sounding (until the machine starts automatic reception of FAX data if in the FAX mode or enters the TAD mode if set in the TEL mode, according to the preset number of ringers).

WSW37 (Function setting 15)

Selector No.	Function	Setting and Specifications
1	Printout of the stored image data of an unsent document onto the error report	0: No 1: Yes
2	Erasure of the stored image data of an unsent document at the time of the subsequent in-memory message transmission	0: No 1: Yes
3 8	Not used.	

- **Selector 1: Printout of the stored image data of an unsent document onto an error report**

This selector determines whether or not the 1st-page image data of a document will be printed out onto the error report if the document image data stored in the temporary memory cannot be transmitted normally.

- **Selector 2: Erasure of the stored image data of an unsent document at the time of the subsequent in-memory message transmission**

If in-memory message transmission fails repeatedly when selector 1 is set to "1," the temporary memory will be occupied with image data. Setting selector 2 to "1" will automatically erase the stored 1st-page image data of an unsent document at the time of the subsequent in-memory message transmission only when recording paper or toner runs out.

WSW38 (Function setting 16 in V. 34 mode)

Selector No.	Function	Setting and Specifications
1 2	Setting of the equalizer	No. 1 2 0 X : Automatic 1 0 : Fixed to 4 points 1 1 : Fixed to 16 points
3	Sending level of guard tone at phase 2	0: Normal - 7 db 1: Normal
4	Stepping down the transmission speed at fallback each	0: 2400 bps 1: 4800 bps
5 6	Automatic control of modem's EQM gain for proper transmission speed choice	No. 5 6 0 0 : For higher transmission speed than the current setting 0 1 : No change from the current setting 1 0 : For lower transmission speed than the current setting 1 1 : For further lower transmission than the setting made by 1, 0
7	Redialing when a communications error occurs	0: ON 1: OFF
8	Not used.	

NOTE: WSW38 takes effect only in V. 34 mode.

- **Selectors 1 and 2: Setting of the equalizer**

These selectors set the equalizer's training level to be applied if the machine fails to send training due to weak line connection. If these selectors are set to "0, X," the modem will automatically set the appropriate training level.

- **Selector 3: Sending level of guard tone at phase 2**

This selector sets the sending level of guard tone for 1800 Hz to be sent at Phase 2 in the V. 34 mode.

- **Selector 4: Stepping down the transmission speed at fallback each**

This selector determines how much the modem steps down the transmission speed at fallback when called by the remote station. If this selector is set to "1," the modem may step down the transmission speed from 33600 bps to 28800 bps by one-time fallback.

- **Selectors 5 and 6: Automatic control of modem's EQM gain for proper transmission speed choice**

These selectors determine how the modem controls the EQM (Eye Quality Monitor) gain for proper choice of the transmission speed, which applies if the modem selects higher transmission speed than the possible speed so that it always repeats falling back.

WSW39 (Transmission speed setting in V. 34 mode)

Selector No.	Function	Setting and Specifications
1 4	First transmission speed choice for fallback	No. 1 2 3 4 No. 5 6 7 8 0 0 0 0 : 2400 bps 0 0 0 1 : 4800 bps 0 0 1 0 : 7200 bps 0 0 1 1 : 9600 bps 0 1 0 0 : 12000 bps 0 1 0 1 : 14400 bps 0 1 1 0 : 16800 bps 0 1 1 1 : 19200 bps 1 0 0 0 : 21600 bps 1 0 0 1 : 24000 bps 1 0 1 0 : 26400 bps 1 0 1 1 : 28800 bps 1 1 0 0 : 31200 bps 1 1 0 1 : 33600 bps 1 1 1 0 : 33600 bps 1 1 1 1 : 33600 bps
5 8	Last transmission speed choice for fallback	

NOTE: WSW39 takes effect only in V. 34 mode. For the transmission speed setting in other modes, refer to WSW19.

• **Selectors 1 through 8: First and last choices of transmission speed for fallback**

These selectors are used to set the modem speed range. With the first transmission speed choice specified by selectors 1 through 4, the machine attempts to establish the transmission link via the modem. If the establishment fails, the machine automatically steps down to the next highest speed and attempts to establish the transmission link again. The machine repeats this sequence while stepping down the transmission speed to the last choice specified by selectors 5 through 8.

If the modem always falls back to a low transmission speed (e.g., 24,000 bps), set the first transmission speed choice to the lower one (e.g., modify it from 31,200 bps to 26,400 bps) in order to deactivate the high-speed modem function and reduce the training time for shorter transmission time.

WSW39 will be limited by selectors 3 through 8 of WSW40.

WSW40 (Function setting 17 in V. 34 mode)

Selector No.	Function	Setting and Specifications				
1 2	Not used.					
3 8	Masking of symbol rate(s)	Not masking		Masking		
		No. 3	0	1	3429 symbols/sec	
		No. 4	0	1	3200 symbols/sec	
		No. 5	0	1	3000 symbols/sec	
		No. 6	0	1	2800 symbols/sec	
		No. 7	-	-	Not used.	
		No. 8	0	1	2400 symbols/sec	

NOTE: WSW40 takes effect only in V. 34 mode.

• **Selectors 3 and 8: Masking of symbol rate(s)**

These selectors allow you to limit the transmission speed range in V. 34 mode by masking the desired symbol rate(s). Transmission speeds assigned to the symbol rates are listed below. The setting made by these selectors will limit the setting made by selectors 1 through 4 of WSW39.

If selector 3 is set to "1" to mask the 3429 symbols/second when the first transmission speed choice is 33600 bps (specified by selectors 1 through 4 of WSW39), for example, then the allowable maximum transmission speed will be limited to 31200 bps. If selector 8 is set to "1" to mask the 2400 symbols/second when the first transmission speed choice is 33600 bps, then the allowable maximum transmission speed remains 33600 bps.

If selector 8 is set to "1" to mask the 2400 symbols/second when the first transmission speed choice is 21600 bps (specified by selectors 1 through 4 of WSW39), then the allowable maximum transmission speed remains 21600 bps but the minimum transmission speed will be limited to 4800 bps.

Symbol rate	Transmission speed (bps)	Symbol rate	Transmission speed (bps)	Symbol rate	Transmission speed (bps)
2400	2400	3000	4800	3429	4800
	4800		7200		7200
	7200		9600		9600
	9600		12000		12000
	12000		14400		14400
	14400		16800		16800
	16800		19200		19200
	19200		21600		21600
	21600		24000		24000
	24000		26400		26400
2800	4800	3200	4800		28800
	7200		7200		31200
	9600		9600		33600
	12000		12000		
	14400		14400		
	16800		16800		
	19200		19200		
	21600		21600		
	24000		24000		
	26400		26400		

WSW41 (CCD fluorescent lamp and modem attenuator in V. 34 mode)

Selector No.	Function	Setting and Specifications
1 3	ON-duration of the fluorescent lamp built in the CCD unit	No. 1 2 3 0 0 0 : 16 hours 0 0 1 : 24 hours 0 1 0 : 12 hours 0 1 1 : 8 hours 1 0 0 : 4 hours 1 0 1 : 2 hours 1 1 0 : 10 minutes 1 1 1 : 0 minute
4	Not used.	
5 8	Modem attenuator	No. 5 6 7 8 0 0 0 0 : -10 dBm 0 0 0 1 : -11 dBm 0 0 1 0 : -12 dBm 0 0 1 1 : -13 dBm 0 1 0 0 : -14 dBm 1 1 1 1 : -25 dBm

NOTE: Selectors 5 through 8 take effect only in V. 34 mode.

NOTE: Selectors 1 through 3 are applicable only to models equipped with a flat-bed scanner.

- **Selectors 1 through 3: ON-duration of the fluorescent lamp built in the CCD unit**

If the scanning operation is started when the fluorescent lamp is off, then the lamp will come on and stay on for the time length specified by these selectors.

If these selectors are set to "1, 1, 1," the fluorescent lamp will go off after the scanning sequence.

- **Selectors 5 through 8: Modem attenuator**

These selectors are used to adjust the transmitting level of the modem when the reception level at the remote station is improper due to line loss. This function applies to super G3 protocol signals.

WSW42 (Function setting 18)

Selector No.	Function	Setting and Specifications
1	Incoming mail server POP* ¹	0: OFF 1: ON
2	Incoming mail server SMTP* ²	0: OFF 1: ON
3	Internet-FAX forward function	0: OFF 1: ON
4	JBIG* ³ coding system	0: Disabled 1: Enabled
5 8	Not used.	

*¹ POP: Post Office Protocol

*² SMTP: Simple Mail Transfer Protocol

*³ JBIG: Joint Bi-level Image Group

NOTE: Selectors 1 through 3 are applicable to those models equipped with LAN interface.

● **Selector 3: Internet-FAX forward function**

If this selector is set to "ON," the machine may forward a FAX message received through Internet to other remote G3 facsimile machine.

WSW43 (Function setting 19)

Selector No.	Function	Setting and Specifications
1	Not used.	
2 3	Wait time for PCFax reception (Class 2) and FPTS command transmission	No. 2 3
		0 0 : 50 ms
		0 1 : 100 ms
		1 0 : 150 ms
		1 1 : 0 ms
4 5	Detection time of 2100 Hz CED or ANSam	No. 4 5
		0 0 : 200 ms
		0 1 : 300 ms
		1 0 : 400 ms
		1 1 : 500 ms
6 8	Not used.	

WSW44 (Speeding up scanning-1)

Selector No.	Function	Setting and Specifications
1 5	Not used.	
6 8	Effective time length of the white level compensation data obtained beforehand	No. 6 7 8 0 0 0 : Obtained compensation data ineffective 0 0 1 : 1 min. 0 1 0 : 3 min. 0 1 1 : 5 min. 1 0 0 : 10 min. 1 0 1 : 15 min. 1 1 0 : 20 min. 1 1 1 : 30 min.

NOTE: WSW44 is applicable only to models equipped with a flat-bed scanner.

● **Selectors 6 through 8: Effective time length of the white level compensation data obtained beforehand**

If you set documents in the ADF and the document front sensor detects them or if you open the document tray ASSY and the document tray open sensor detects the open state, then the controller will make correction of the reference voltage to be applied to white level compensation for document scanning before the Copy button is pressed.

These selectors determine how long compensation data obtained beforehand will keep effective.

WSW45 (Speeding up scanning-2)

Selector No.	Function	Setting and Specifications
1 3	Delay time from when documents are set until the ADF starts drawing them in	No. 1 2 3 0 0 0 : No automatic drawing-in 0 0 1 : 1 sec. 0 1 0 : 2 sec. 0 1 1 : 3 sec. 1 0 0 : 4 sec. 1 0 1 : 5 sec. 1 1 0 : 6 sec. 1 1 1 : 7 sec.
4 6	Periodical correction intervals of the reference voltage to be applied to white level compensation for document scanning, during standby	No. 4 5 6 0 0 0 : No correction of reference voltage during standby 0 0 1 : 10 sec. 0 1 0 : 30 sec. 0 1 1 : 1 min. 1 0 0 : 3 min. 1 0 1 : 5 min. 1 1 0 : 10 min. 1 1 1 : 30 min.
7 8	Not used.	

NOTE: WSW45 is applicable only to models equipped with a flat-bed scanner.

- **Selectors 1 through 3: Delay time from when documents are set until the ADF starts drawing them in**

These selectors determine how long the ADF will delay automatic drawing-in of documents (to the scanning standby position) after you set them in the ADF, as well as determining whether or not the ADF automatically draws in documents.
- **Selectors 4 through 6: Periodical correction intervals of the reference voltage applied to white level compensation for document scanning, during standby**

These selectors set the correction intervals (in seconds) of the reference voltage to be applied to white level compensation for document scanning during standby, as well as determining whether or not the controller makes the reference voltage correction during standby. (Conventionally, the correction has been made immediately before the start of actual scanning)

This function takes effect in copying. Making the correction during standby may shorten the preparation time for copying.

NOTE: Do not access these selectors.

WSW46 (Monitor of power ON/OFF state)

Selector No.	Function	Setting and Specifications
1 2	Monitoring the PC ON/OFF state	No. 1 2 0 0 : Disabled 0 1 : Monitor SELECT IN 1 0 : Monitor STROBE 1 1 : Monitor both SELECT IN and STROBE
3	Parallel port output pins kept at high level	0: Enabled 1: Disabled
4 8	Not used.	

NOTE: Selector 3 is applicable only to models equipped with a parallel interface.

- **Selectors 1 and 2: Monitoring the PC ON/OFF state**

For the related functions, refer to WSW36, selectors 2 and 3.

- **Selector 3: Parallel port output pins kept at high level**

Setting this selector to "0" will keep all parallel output pins of the machine at high level. Use this setting if Resource Manager (bundled with MFC models) installed to WindowsNT running on the connected PC fails to monitor the power ON/OFF state of the machine.

MFC6800/DCP1000

MFC9180/MFC9160

Appendix 3. Circuit Diagrams

- A. Main PCB
- B. Network Control Unit (NCU) PCB
- C. Control Panel PCB
- D. Power Supply PCBs
- E. Relay PCB

Terms in circuit diagrams

セラC: Ceramic capacitor

デンC: Chemical capacitor

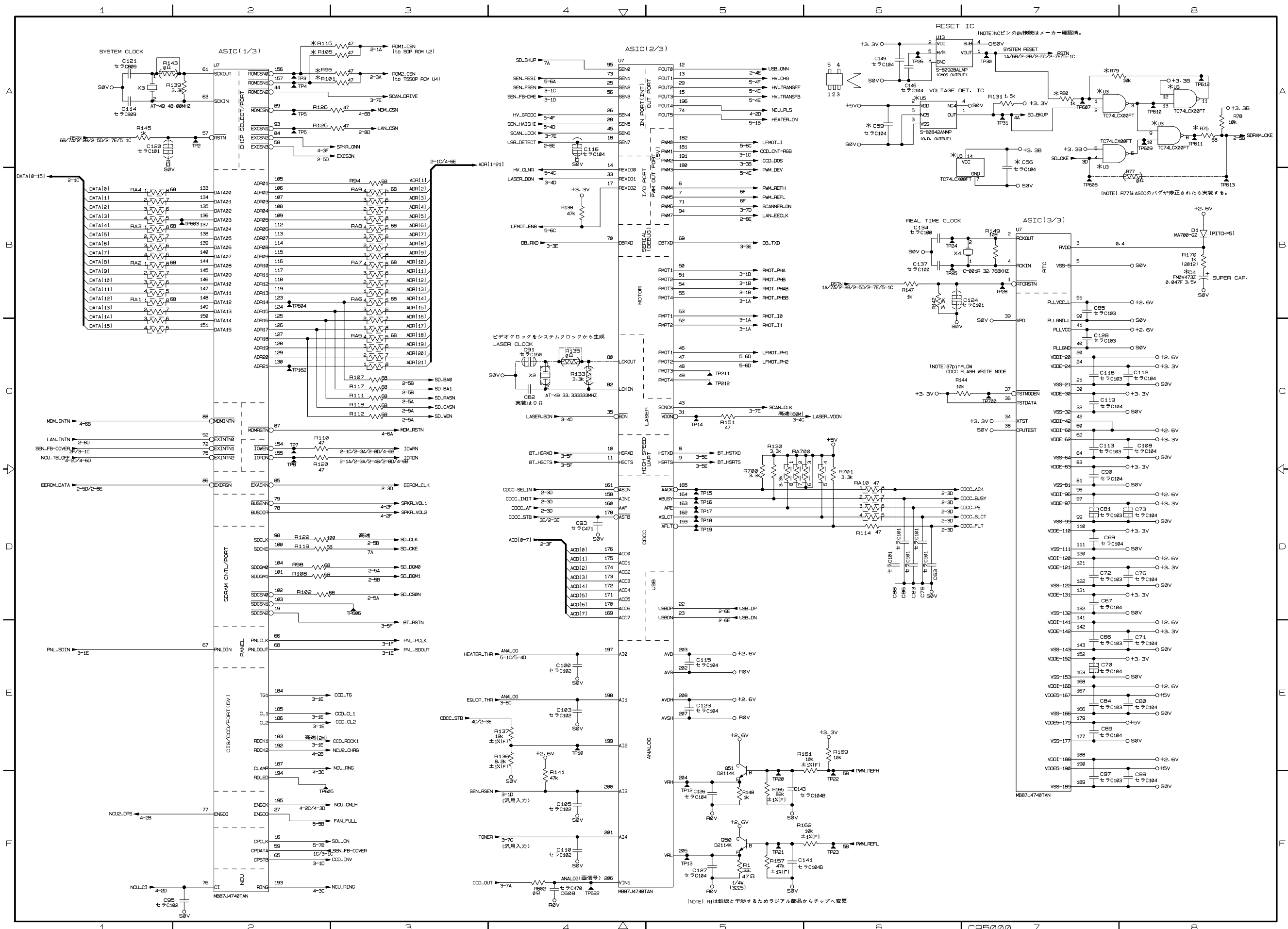

(NOTE) R1は鉄板と干渉するためラジアル部品からチップへ変更

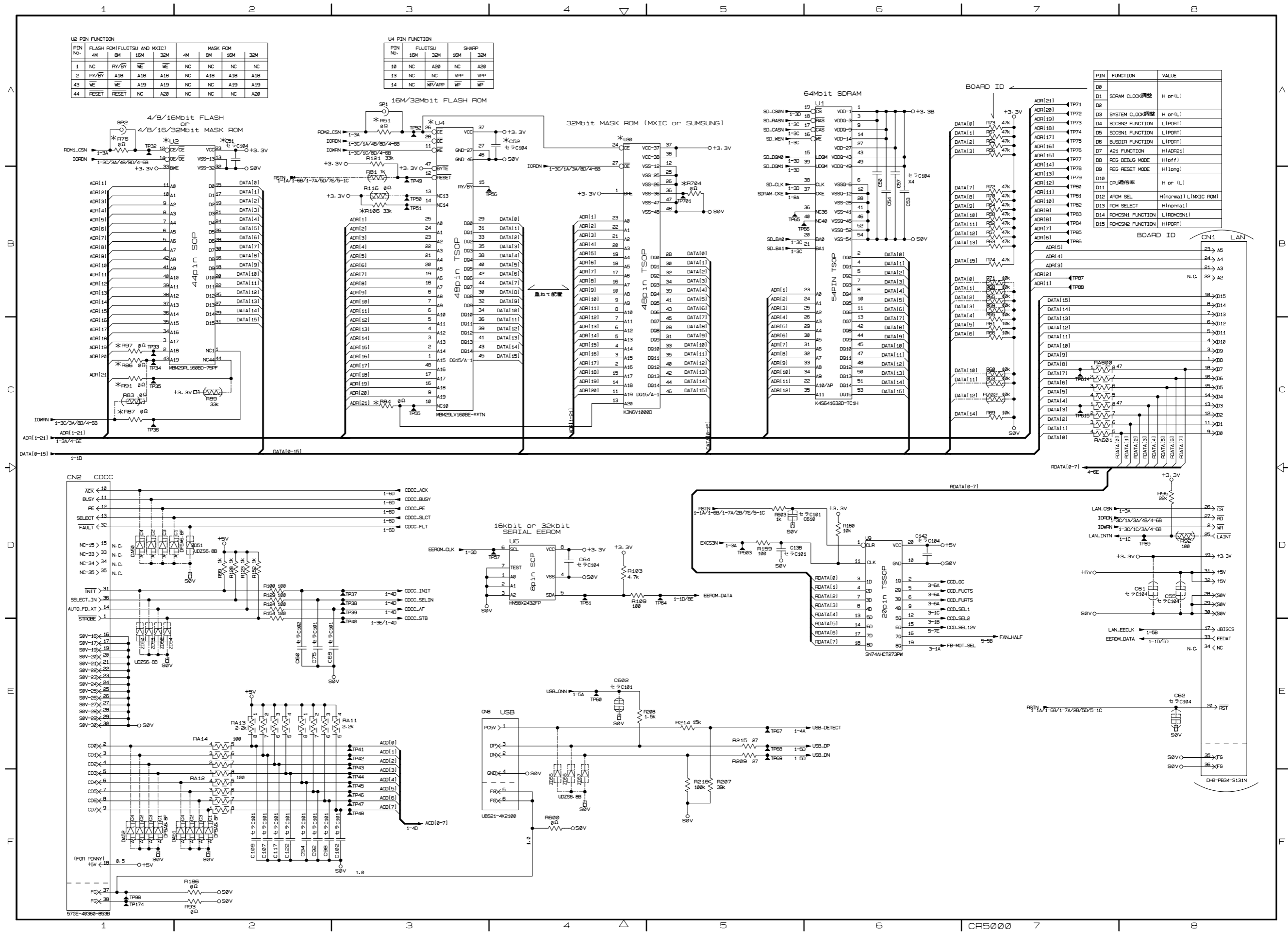

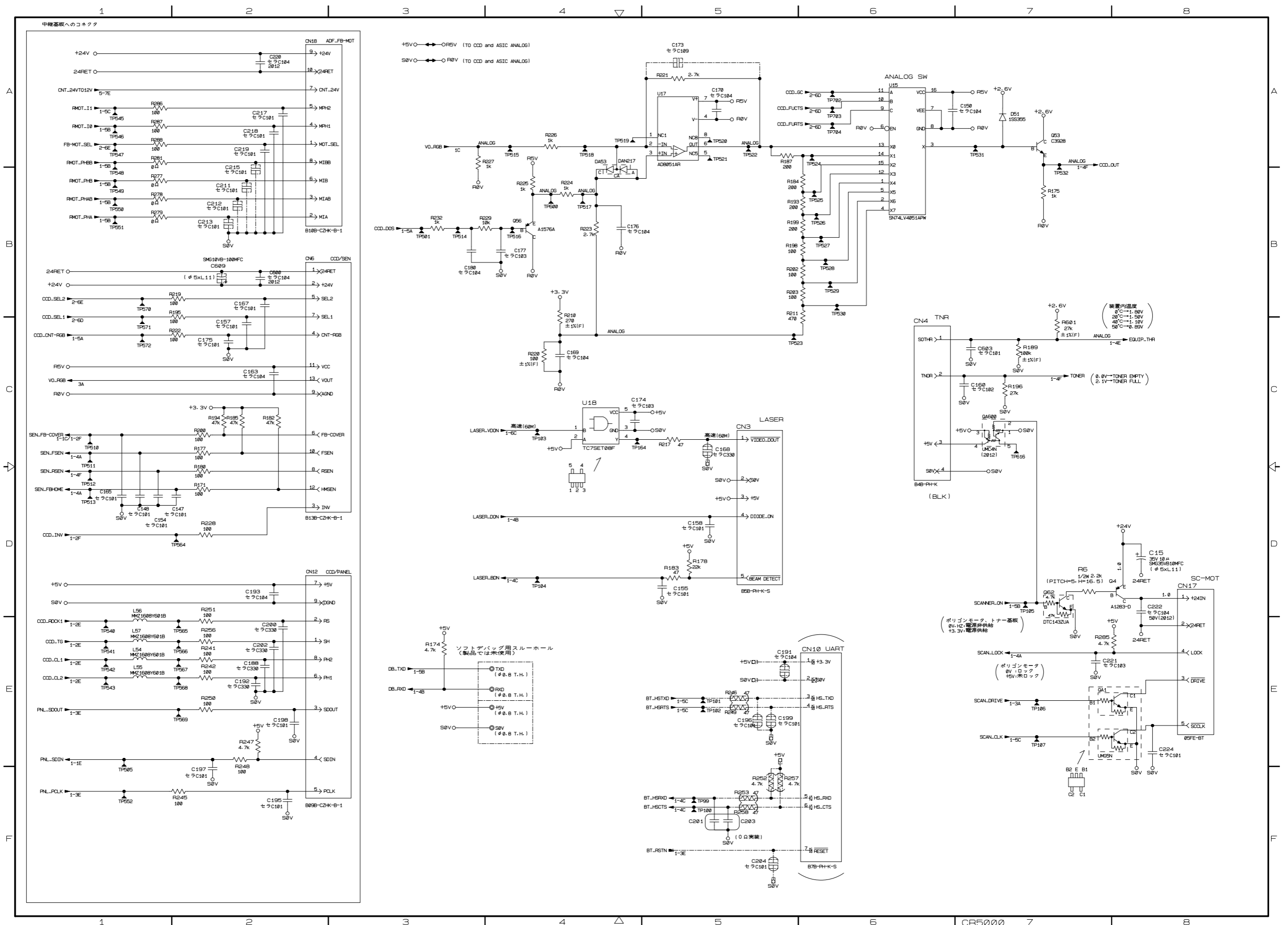

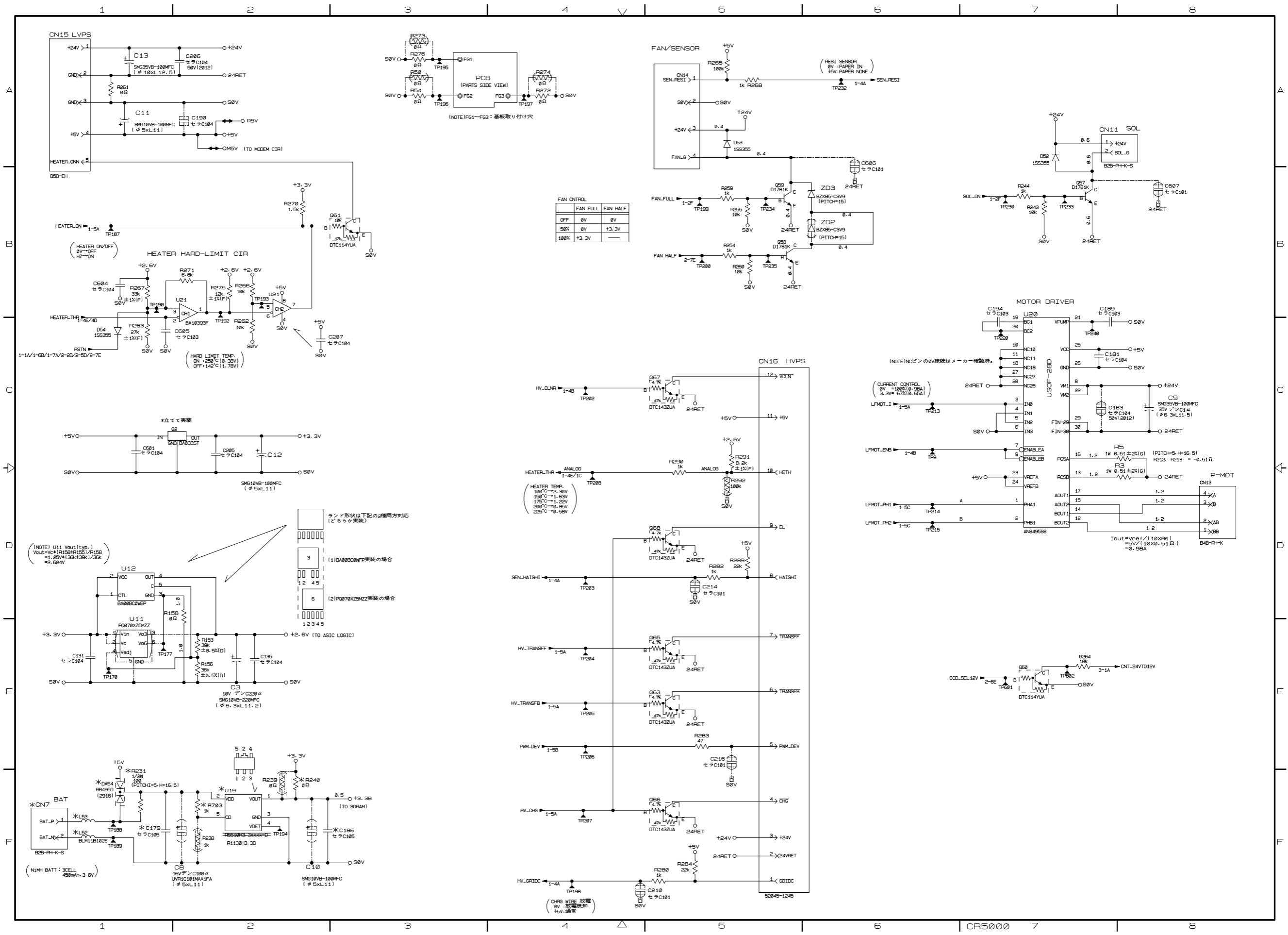

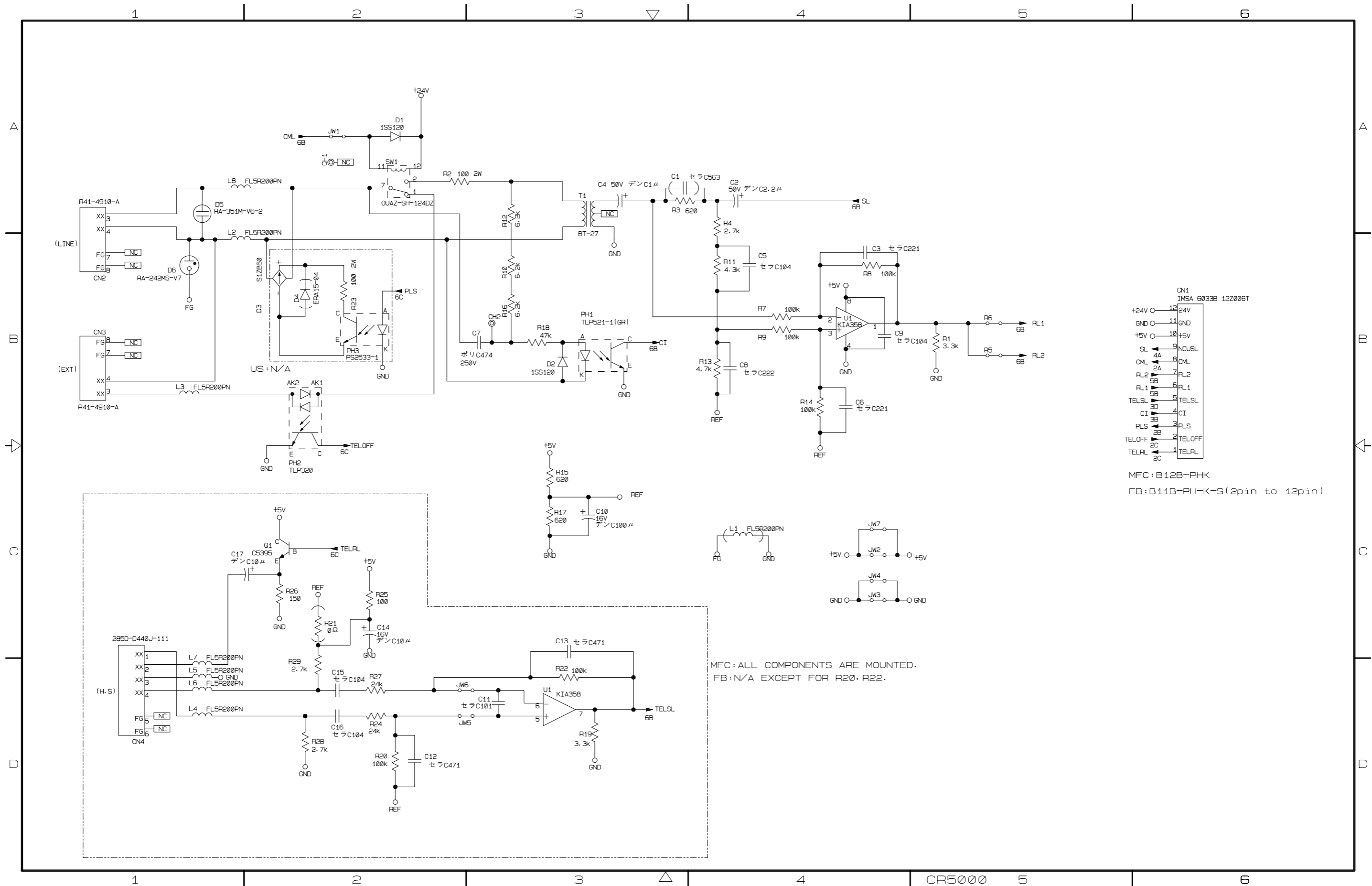

CN1 IMSA-6033B-12Z006T	
+24V	12
GND	11
+5V	10
SL	9
CML	8
RL2	7
RL1	6
TELSL	5
CI	4
PLS	3
TELOFF	2
TELR	1

MFC: B12B-PHK
FB: B11B-PH-K-S (2pin to 12pin)

MFC: ALL COMPONENTS ARE MOUNTED.
FB: N/A EXCEPT FOR R20, R22.

B. NCU PCB
 (U.K., Norway, Netherlands, Finland, Denmark, Sweden)

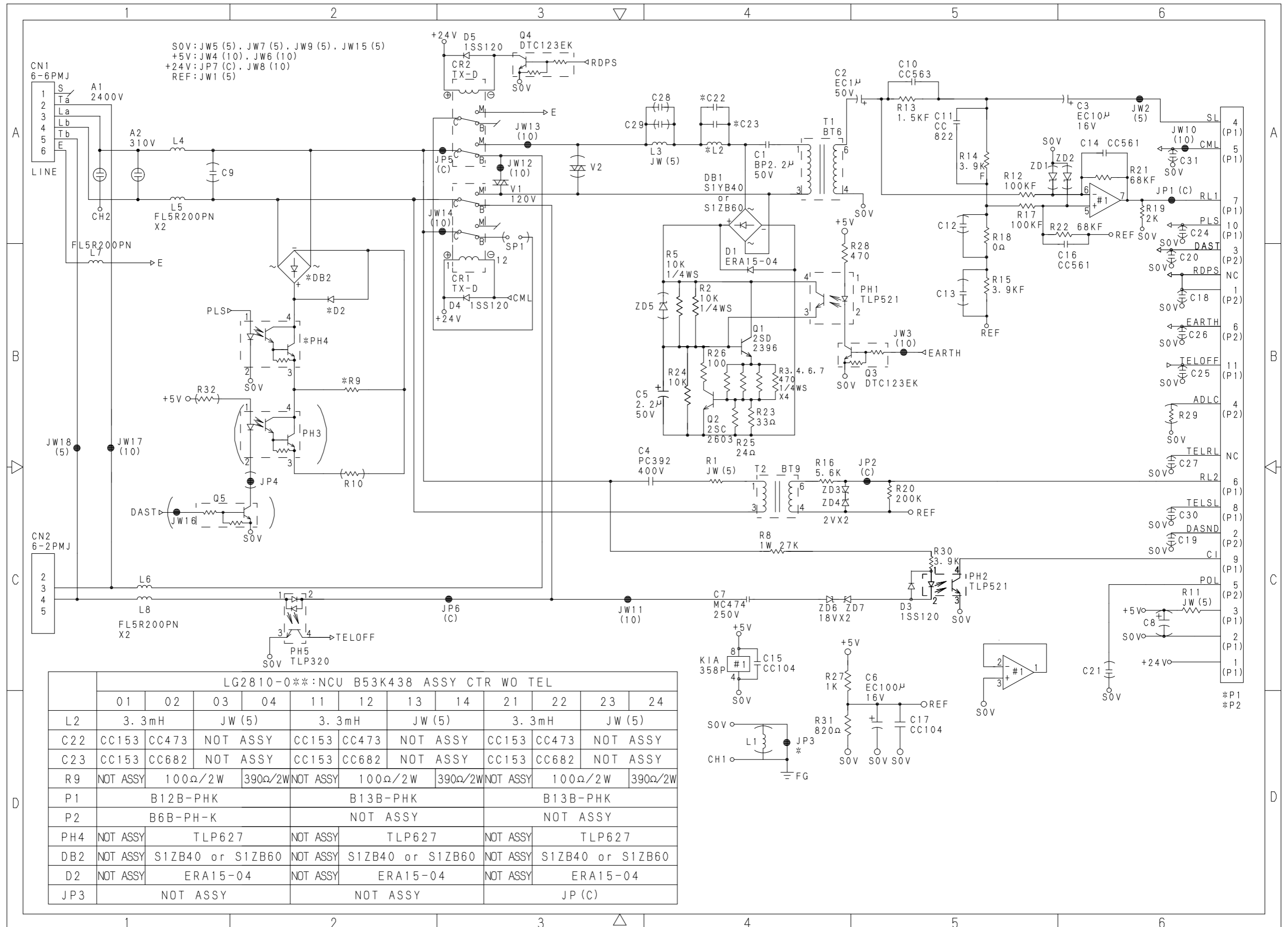

LG2810-0** : NCU B53K438 ASSY CTR WO TEL

	01	02	03	04	11	12	13	14	21	22	23	24
L2	3.3mH		JW (5)		3.3mH		JW (5)		3.3mH		JW (5)	
C22	CC153	CC473	NOT ASSY	CC153	CC473	NOT ASSY	CC153	CC473	NOT ASSY			
C23	CC153	CC682	NOT ASSY	CC153	CC682	NOT ASSY	CC153	CC682	NOT ASSY			
R9	NOT ASSY	100Ω/2W	390Ω/2W	NOT ASSY	100Ω/2W	390Ω/2W	NOT ASSY	100Ω/2W	390Ω/2W	NOT ASSY		
P1	B12B-PHK			B13B-PHK			B13B-PHK					
P2	B6B-PH-K			NOT ASSY			NOT ASSY					
PH4	NOT ASSY	TLP627		NOT ASSY	TLP627		NOT ASSY	TLP627				
DB2	NOT ASSY	S1ZB40 or S1ZB60		NOT ASSY	S1ZB40 or S1ZB60		NOT ASSY	S1ZB40 or S1ZB60				
D2	NOT ASSY	ERA15-04		NOT ASSY	ERA15-04		NOT ASSY	ERA15-04				
JP3	NOT ASSY			NOT ASSY			JP (C)					

B. NCU PCB
 (Germany, France, Belgium, Switzerland, Ireland,
 Austria, Spain, Italy, South Africa)

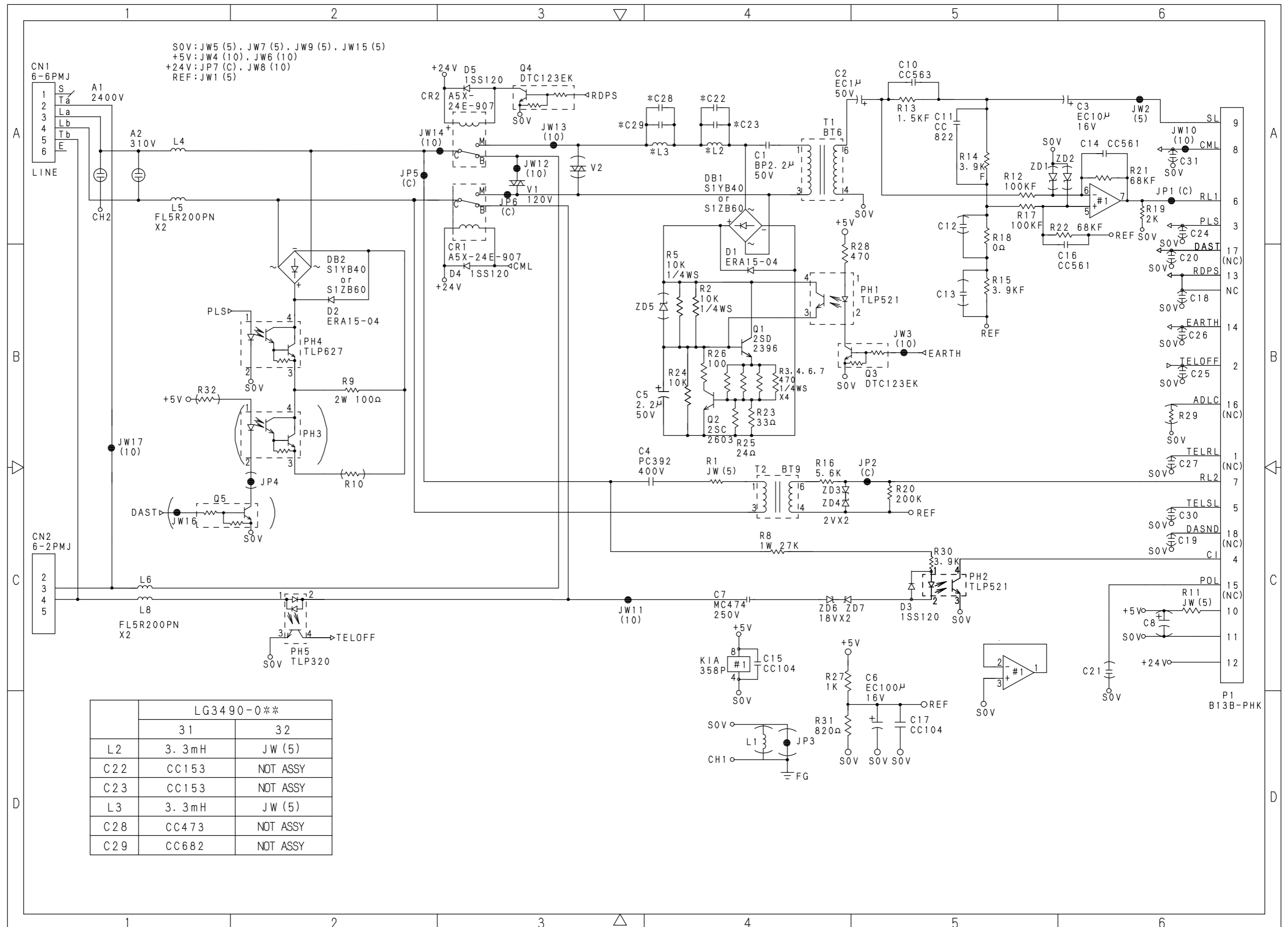

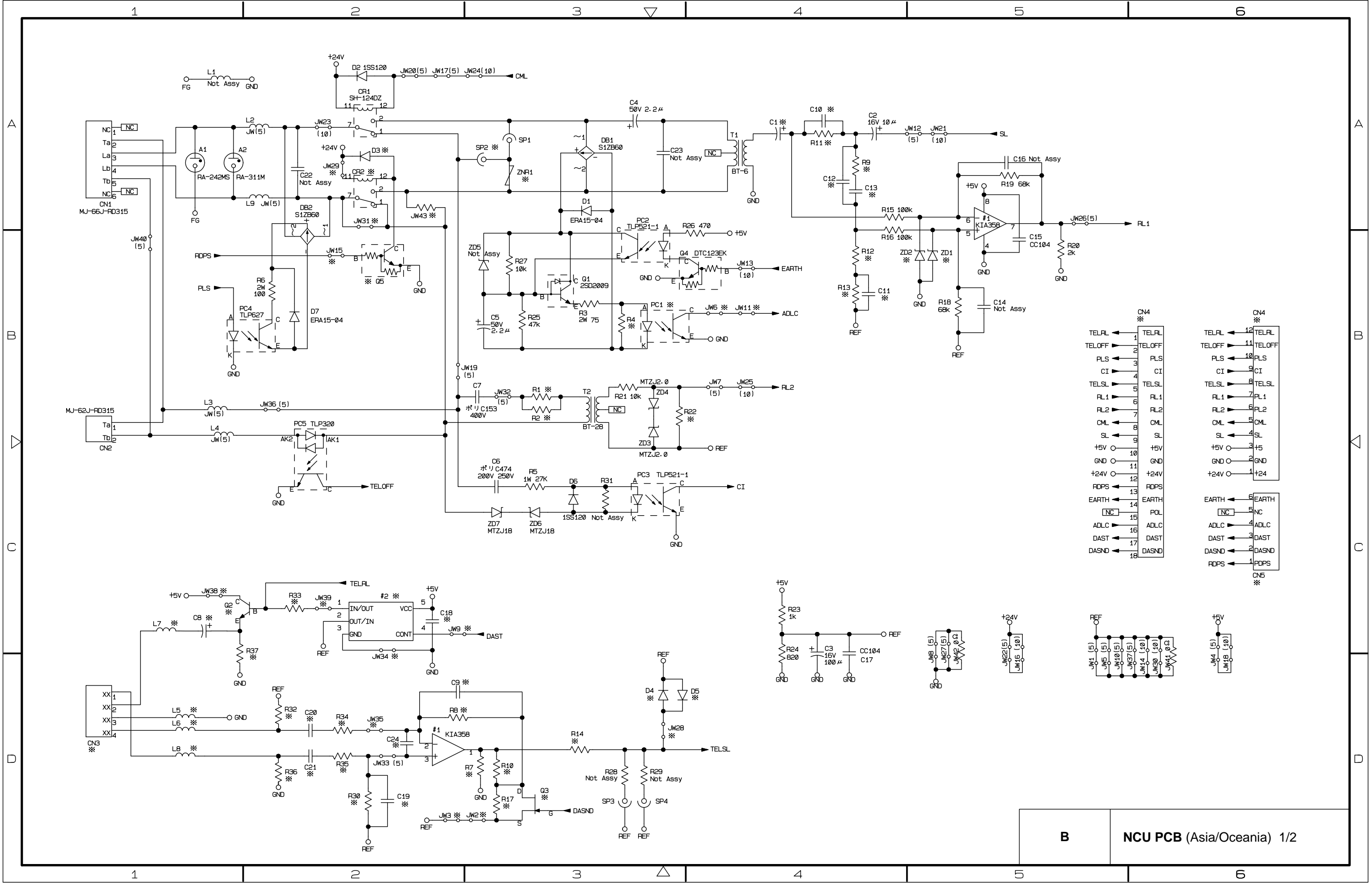

CN4 *		CN4 *	
TELRL	1	TELRL	12
TELOFF	2	TELOFF	11
PLS	3	PLS	10
CI	4	CI	9
TELSL	5	TELSL	8
RL1	6	RL1	7
RL2	7	RL2	6
CML	8	CML	5
SL	9	SL	4
+5V	10	+5V	3
GND	11	GND	2
+24V	12	+24V	1
ROPS	13		
EARTH	14	EARTH	6
NC	15	NC	5
ADLC	16	ADLC	4
DAST	17	DAST	3
DASND	18	DASND	2
		ROPS	1

ASSY	NCU B53K479 ASSY ASIA W/O TEL	NCU B53K479 ASSY OCEANIA W/O TEL
ADRS.	NAME	NAME
ZNR1	Not Assy	ENC121D07A
SP2	Not Assy	1/16W 0
CR2	Not Assy	SH-124DZ
Q5	Not Assy	DTC123EK
D3	Not Assy	1SS120
JW15	Not Assy	JW(10)
JW29	Not Assy	JW (5)
JW31	JW (5)	Not Assy
JW43	1/16W 0	Not Assy
PC1	Not Assy	Not Assy
R4	JW (5)	JW (5)
JW6;JW11	Not Assy	Not Assy
ZD1;ZD2	Not Assy	Not Assy
R1	1/4W 22K	Not Assy
R2	1/4W 22K	JW (5)
R9	1/16W 1% 4.7K	1/16W 1% 2.7K
R11	1/16W 1% 910	1/16W 1% 1.10K
R12	1/16W 1% 2K	CERAMIC 16C224B
R13	1/16W 1% 9.1K	1/16W 1% 3.9K
R22	Not Assy	1/16W 20K
C1	ALUM-ELEC 16B100	ALUM-ELEC 50B10-1
C10	Not Assy	CERAMIC 50C563B
C11	CERAMIC 50C103B	Not Assy
C12	Not Assy	CERAMIC 50C562B
C13	CERAMIC 16C224B	RESISTOR 0
CN3	Not Assy	Not Assy
CN5	Not Assy	Not Assy
CN4	B13B-PH	B13B-PH
Q2	Not Assy	Not Assy
R7	Not Assy	Not Assy
R8;R30	1/16W 0	1/16W 0
R14	Not Assy	Not Assy
R32;R36	Not Assy	Not Assy
R34;R35	Not Assy	Not Assy
R37	Not Assy	Not Assy
C8	Not Assy	Not Assy
C9;C19	Not Assy	Not Assy
C20;C21	Not Assy	Not Assy
C24	Not Assy	Not Assy
JW35;JW38;L5;L6;L7;L8	Not Assy	Not Assy
D4;D5	Not Assy	Not Assy
JW28	Not Assy	Not Assy
#2	Not Assy	Not Assy
R33	Not Assy	Not Assy
C18	Not Assy	Not Assy
JW9;JW34;JW39	Not Assy	Not Assy
Q3	Not Assy	Not Assy
R10	1/16W 0	1/16W 0
R17	Not Assy	Not Assy
JW2;JW3	Not Assy	Not Assy
L1	JW (5)	JW (5)

C. Control Panel PCB

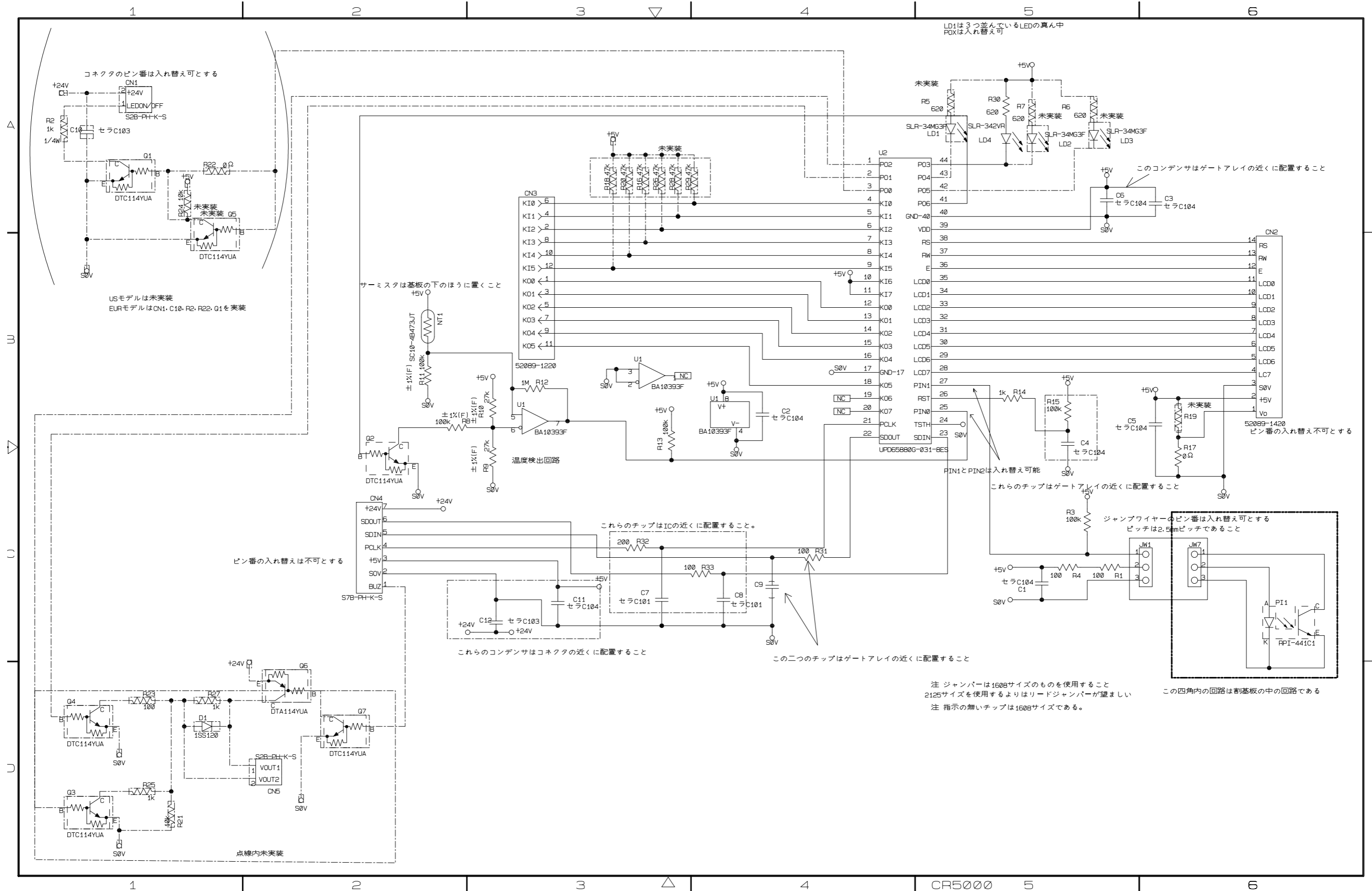

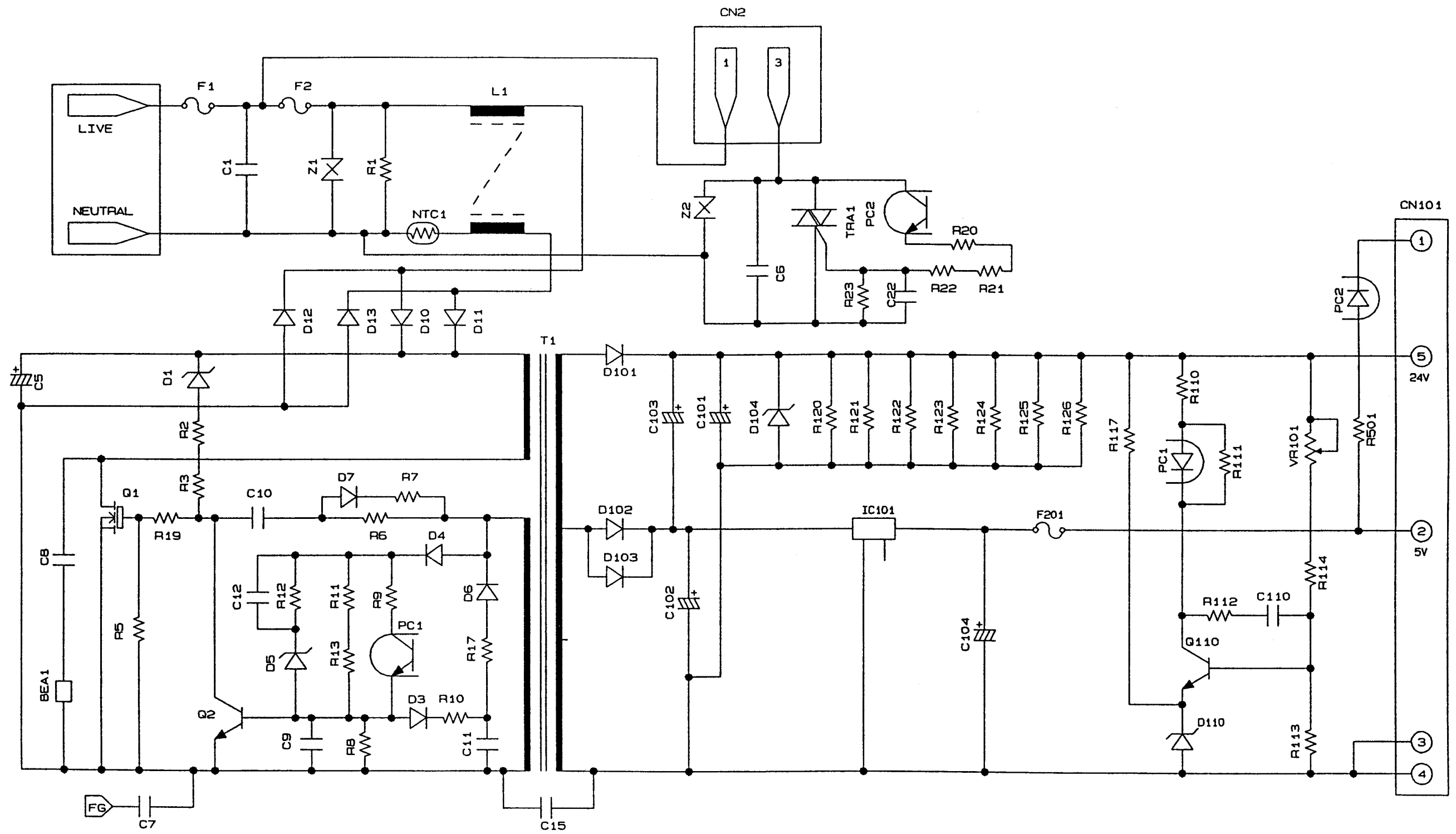

D	Power Supply PCB (100-120V) Low-voltage power supply
---	--

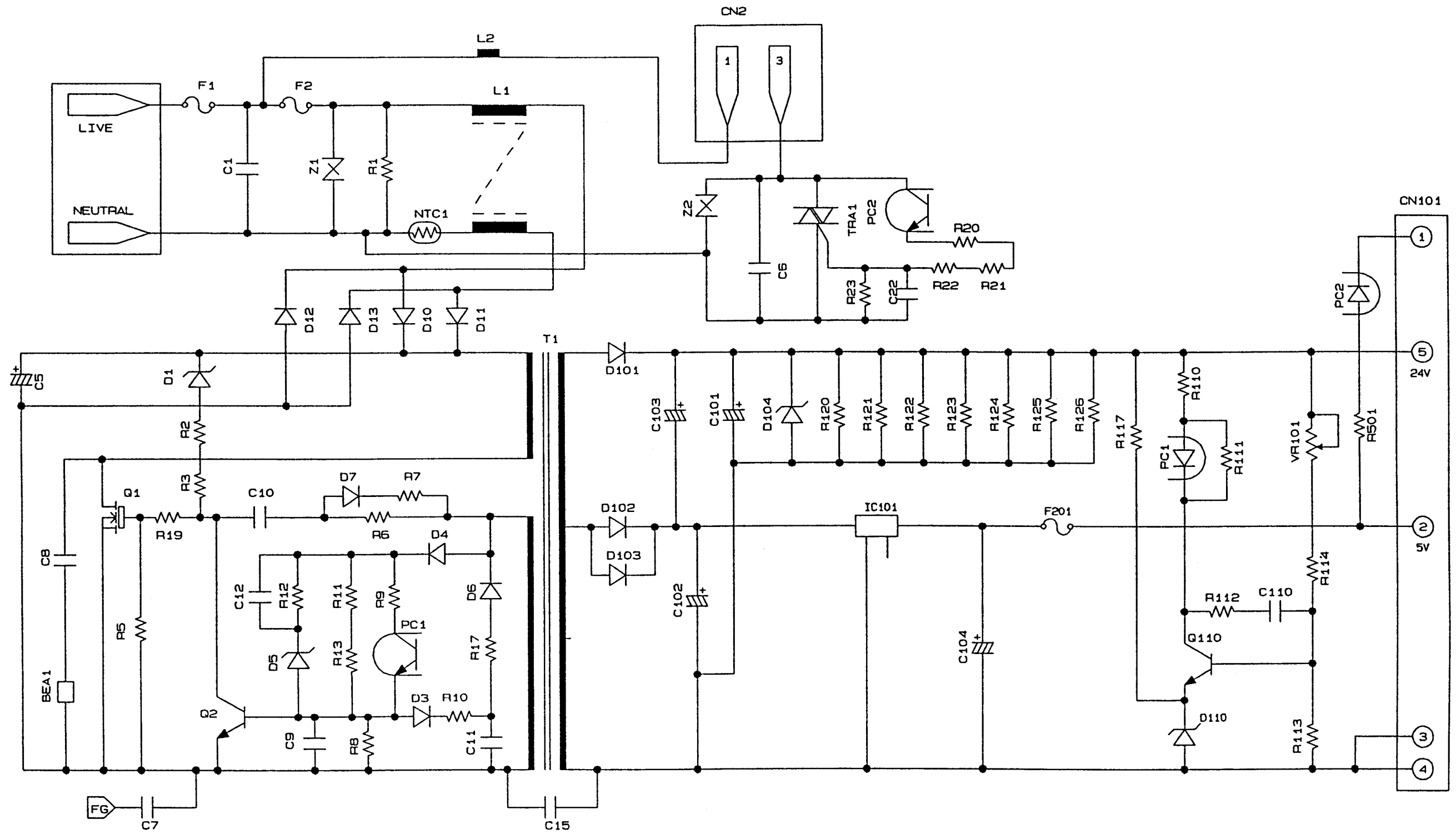

D	Power Supply PCB (200-240V) Low-voltage power supply (Europe)
---	--

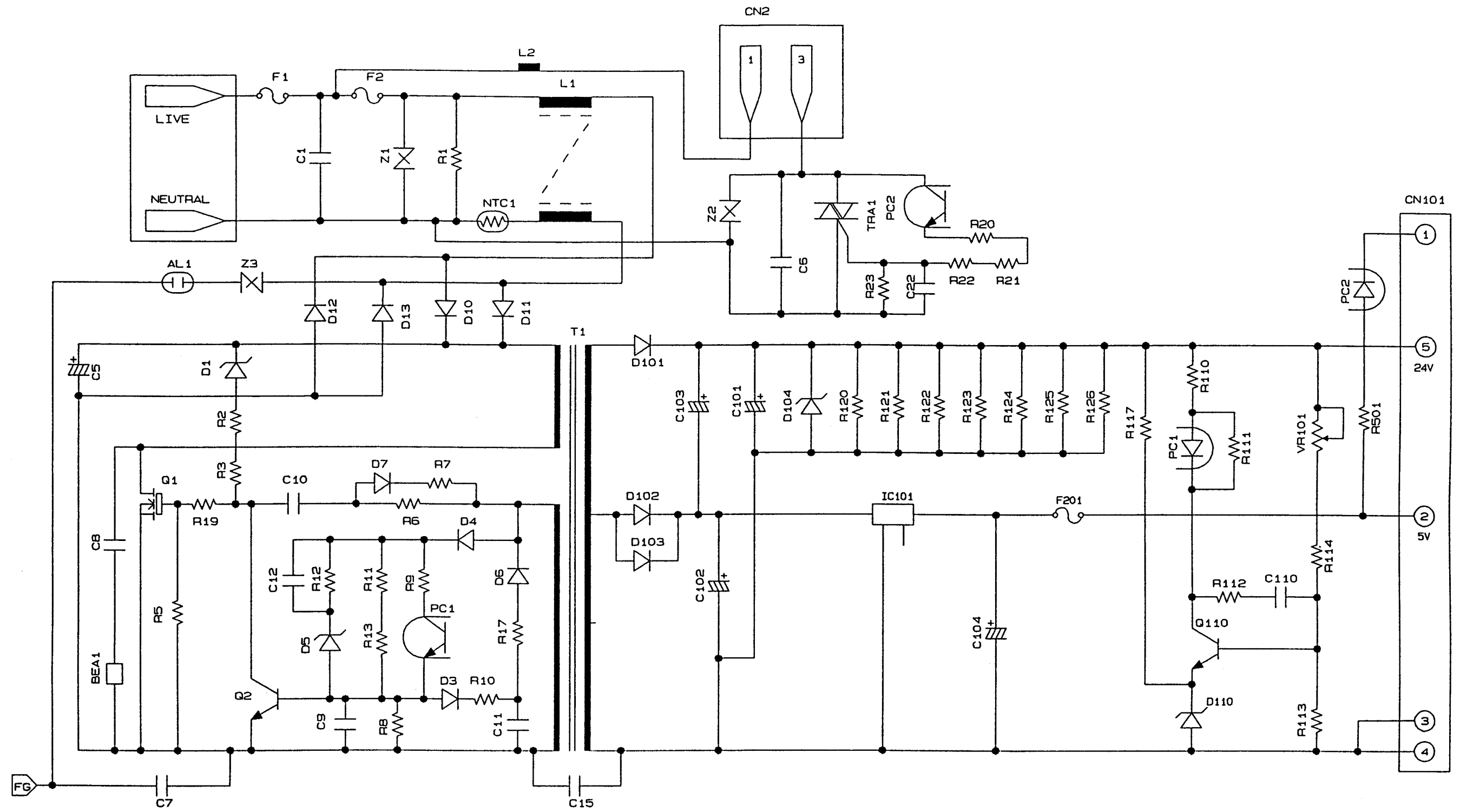

D	Power Supply PCB (200-240V) Low-voltage power supply (Asia, Oceania)
---	---

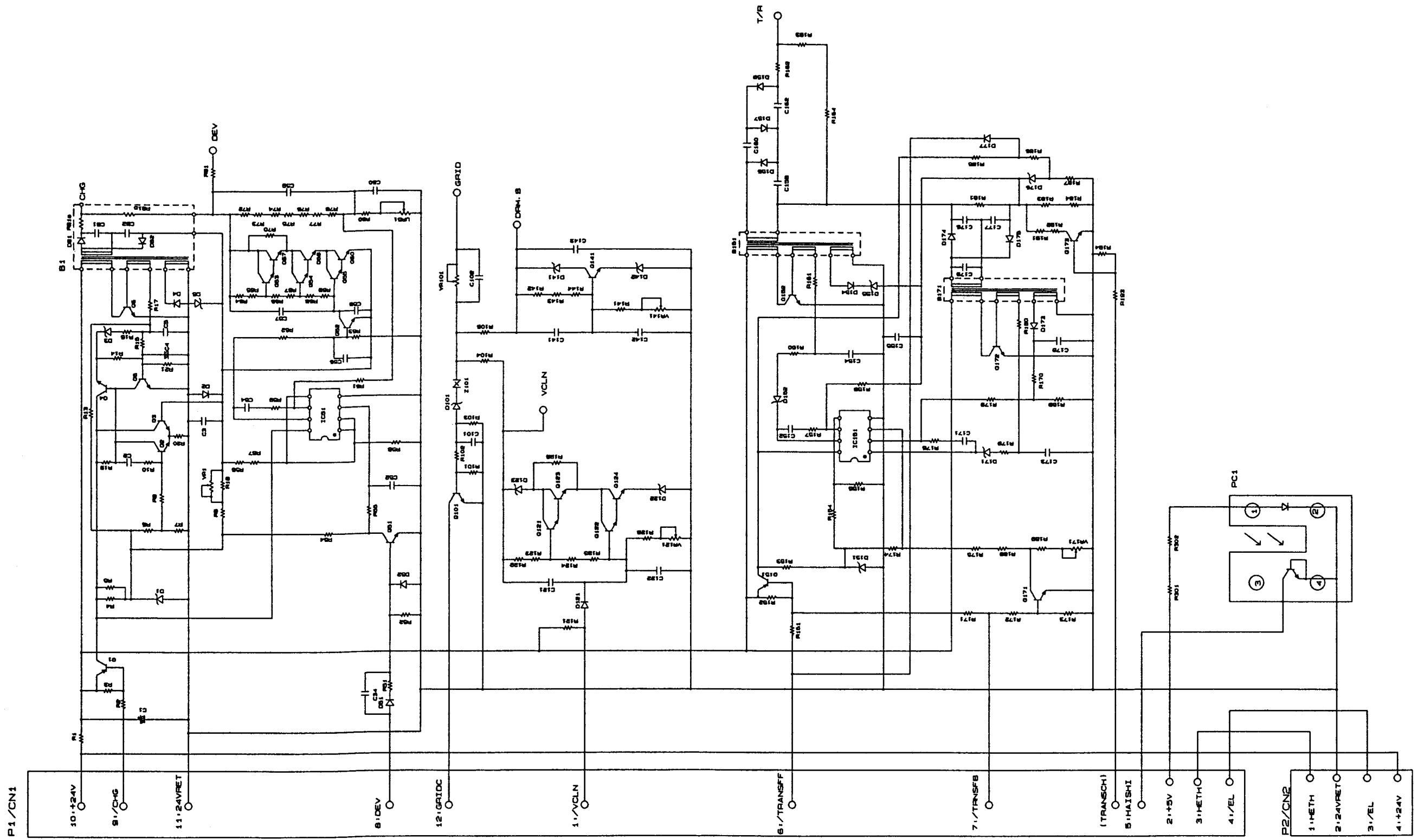

D

Power Supply PCB
High-voltage power supply

E. Relay PCB

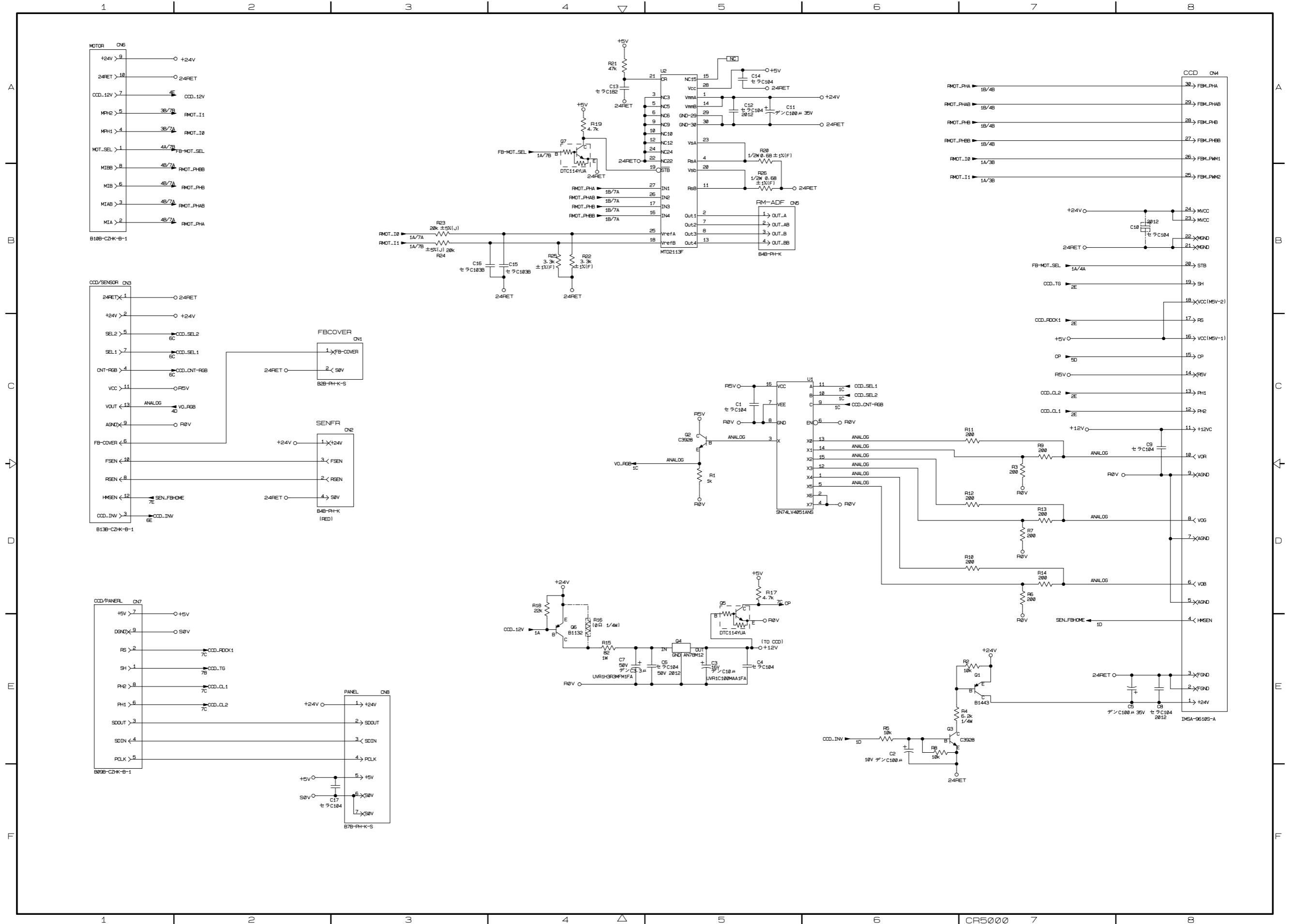

brother®

April '02
SM-FAX003②
8C5613
Printed in Japan